

# List of Repair Groups 944

| General                                    | Technical Data                            | Page 0.1 |
|--|---|----------|
| Repair Groups                              |   | Group    |
|  | Maintenance, Self-diagnosis               | 03       |
| <b>Engine</b>                              | Engine, Crankcase                         | 10       |
|  | Engine, Crankshaft, Pistons               | 13       |
|  | Engine, Cylinder Head and Valve Drive     | 15       |
|  | Engine, Lubrication                       | 17       |
|  | Engine, Cooling                           | 19       |
|  | Fuel Supply                               | 20       |
|  | Air Flow Controlled Fuel Injection        | 24       |
|  | Exhaust System/Emission Controls          | 26       |
|  | Starter, Power Supply, Cruise Control     | 27       |
|  | Ignition System                           | 28       |
|  | DME Diagnosis                             |          |
| <b>Transmission</b>                        | Clutch, Controls                          | 30       |
|  | Torque Converter                          | 32       |
|  | Manual Transmission, Controls, Case       | 34       |
|  | Manual Transmission, Gears, Shafts        | 35       |
|  | Automatic Transmission, Controls, Case    | 37       |
|  | Automatic Transmission, Gears, Valve Body | 38       |
|  | Differential, Transaxle System            | 39       |
| <b>Chassis</b>                             | Front Wheel Suspension                    | 40       |
|  | Rear Wheel Suspension, Axle Shaft         | 42       |
|  | Wheels, Tires, Alignment                  | 44       |
|  | Antiblock System                          | 45       |
|  | Brakes, Mechanical                        | 46       |
|  | Brakes, Hydraulics, Regulator, Booster    | 47       |
|  | Steering                                  | 48       |
| <b>Body</b>                                | Body-Front Section                        | 50       |
|  | Body-Center Section                       | 51       |
|  | Body-Rear Section                         | 53       |
|  | Lids                                      | 55       |
|  | Doors                                     | 57       |
|  | Hardtop                                   | 61       |
|  | Bumpers                                   | 63       |
|  | Glasses, Window Control                   | 64       |
|  | Exterior Equipment                        | 66       |
|  | Interior Equipment                        | 68       |
|  | Seats                                     | 72       |
|  | Seat Covers                               | 74       |
|  | Airbag Diagnosis                          |          |
| <b>Heating, Ventilation, Air Condition</b> | Heater                                    | 80       |
|  | Ventilation                               | 85       |
|  | Air Conditioner                           | 87       |
| <b>Electrics</b>                           | Instruments, Fuel Gauge, Alarm System     | 90       |
|  | Radio, Telephone                          | 91       |
|  | Windshield Wipers and Washer              | 92       |
|  | Exterior Lights, Lamps, Switches          | 94       |
|  | Interior Lights                           | 96       |
|  | Wiring                                    | 97       |

|   | Page    |
|---|---------|
| <b>General data</b>   |         |
| Technical data (Type 016 J and 016 K) . . . . .                                     | 30 - 01 |
| Technical data (Type 016 J and 016 K, Mod. 85/2 onward) . . . . .                   | 30 - 02 |
| Technical data (Type 016 J/K and 083 D) . . . . .                                   | 30 - 03 |
| Technical data (Type 083 F) . . . . .   | 30 - 04 |
| Tightening torques (Type 016 J and 016 K) . . . . .                                 | 30 - 05 |
| Technical data, clutch . . . . .  | 30 - 07 |
| <b>Clutch, Control</b>  |         |
| Checking clutch play, adjusting clutch spring . . . . .                             | 30 - 1  |
| Checking condition of clutch drive disk . . . . .                                   | 30 - 2  |
| Checking release travel, bleeding hydraulic clutch system . . . . .                 | 30 - 3  |
| Clutch, removing and installing . . . . .   | 30 - 5  |
| Clutch control, disassembling and assembling . . . . .                              | 30 - 13 |
| Checking drive disk . . . . .   | 30 - 16 |
| Checking pressure plate . . . . .   | 30 - 17 |
| Overhauling slave cylinder . . . . .  | 30 - 19 |
| <b>Automatic clutch, Torque convertor</b>   |         |
| Checking convertor (Type 087 M and 087 N) . . . . .                                 | 32 - 1  |
| Draining convertor (Type 087 M and 087 N) . . . . .                                 | 32 - 2  |
| Installing convertor (Type 087 M and 087 N) . . . . .                               | 32 - 3  |
| <b>Manual transmission, Control, Housing</b>  |         |
| Gearbox, removing and installing (Type 016 J and 016 K) . . . . .                   | 34 - 1  |
| Gearbox, removing and installing, Type 016 J and 016 K (Mod. 85/2 onward) . . . . . | 34 - 4  |
| Adjusting shift . . . . .   | 34 - 5  |
| Checking oil level, replacing transmission oil . . . . .                            | 34 - 7  |
| Transfer box, removing and installing (Type 016 J and 016 K) . . . . .              | 34 - 9  |
| Transfer box, disassembling and assembling (Type 016 J and 016 K) . . . . .         | 34 - 15 |
| Rear cover, disassembling and assembling (Type 016 J and 016 K) . . . . .           | 34 - 27 |
| End plate, disassembling and assembling (Type 016 J and 016 K) . . . . .            | 34 - 31 |
| Transmission case, disassembling and assembling (Type 016 J and 016 K) . . . . .    | 34 - 39 |
| <b>Manual transmission, Gears, Shafts</b>   |         |
| Input shaft, disassembling and assembling (Type 016 J and 016 K) . . . . .          | 35 - 1  |
| Output shaft, disassembling and assembling (Type 016 J and 016 K) . . . . .         | 35 - 7  |



**Automatic transmission**

Technical data (Type 087 M and 087 N) . . . . . 37 - 01  
 Identification code for transmission (Type 087 M and 087 N) . . . . . 37 - 02  
 Technical data (Type 087 M and 087 N) . . . . . 37 - 03  
 Position of the shift elements in the various selector lever positions or  
 gears (Type 087 M and 087 N) . . . . . 37 - 04  
 Planetary gear with shift elements (Type 087 M and 087 N) . . . . . 37 - 05  
 Tightening torques (Type 087 M and 087 N) . . . . . 37 - 07  
 Selector lever cable, removing and installing (Type 087 M and 087 N) . . . . . 37 - 1  
 Throttle and control pressure cable, removing and installing (Type 087 M and 087 N) . . 37 - 8a  
 Adjusting throttle and control pressure cable (Type 087 M and 087 N) . . . . . 37 - 11  
 Functional test (Type 087 M and 087 N) . . . . . 37 - 13  
 Troubleshooting table (Type 087 M and 087 N) . . . . . 37 - 17  
 Transmission, removing and installing (Type 087 M and 087 N) . . . . . 37 - 19

**Automatic transmission, Gears, Regulation**

Replacing ATF fluid, cleaning ATF filter (Type 087 M and 087 N) . . . . . 38 - 1  
 Flushing ATF cooler and line system . . . . . 38 - 2c  
 Disconnecting and connecting planetary gear to final drive (Type 087 M and 087 N) . . . 38 - 3  
 Turbine-shaft seal, removing and installing (Type 087 M and 087 N) . . . . . 38 - 7  
 Adjusting axial play - planetary gear/final drive (Type 087 M and 087 N) . . . . . 38 - 9  
 Planetary gear, disassembling and assembling (Type 087 M and 087 N) . . . . . 38 - 11  
 Ring gear, disassembling and assembling (Type 087 M and 087 N) . . . . . 38 - 19  
 Overrunning clutch, disassembling and assembling (Type 087 M und 087 N) . . . . . 38 - 21  
 Overrunning clutch with plastic cage, disassembling and assembling  
 (Type 087 M and 087 N) . . . . . 38 - 22a  
 Forward clutch, disassembling and assembling (Type 087 M and 087 N) . . . . . 38 - 23  
 Direct and reverse clutch, disassembling and assembling (Type 087 M and 087 N) . . . 38 - 27  
 Oil pump, disassembling and assembling (Type 087 M and 087 N) . . . . . 38 - 33  
 Valve body, removing and installing (Type 087 M and 087 N) . . . . . 38 - 35  
 Transfer and intermediate plates, removing and installing (Type 087 M and 087 N) . . . 38 - 39  
 Valve body, disassembling and assembling (Type 087 M and 087 N) . . . . . 38 - 45  
 2nd gear brake, disassembling and assembling (Type 087 M and 087 N) . . . . . 38 - 55  
 Regulator, disassembling and assembling (Type 087 M and 087 N) . . . . . 38 - 57  
 Parking lock, disassembling and assembling (Type 087 M and 087 N) . . . . . 38 - 59

**Differential, Transaxle system**

Differential, removing and installing (Type 016 J and 016 K) . . . . . 39 - 1  
 Differential, disassembling and assembling (Type 016 J and 016 K) . . . . . 39 - 5

|   | Page      |
|---|-----------|
| Adjusting pinion and ring gear (Type 016 J and 016 K) . . . . .             | 39 - 11   |
| Tightening torques (Type 087 M and 087 N) . . . . .                         | 39 - 101  |
| Checking oil level in rear final drive (Type 087 M and 087 N) . . . . .     | 39 - 103  |
| Final drive, disassembling and assembling (Type 087 M and 087 N) . . . . .  | 39 - 105  |
| Differential, disassembling and assembling (Type 087 M and 087 N) . . . . . | 39 - 119  |
| Limited slip differential (40%), disassembling and assembling . . . . .     | 39 - 122a |
| Adjusting drive set (Type 087 M and 087 N) . . . . .                        | 39 - 123  |
| Central pipe, removing and installing (Type 087 M and 087 N) . . . . .      | 39 - 135  |
| Central pipe, disassembling and assembling (Type 087 M and 087 N) . . . . . | 39 - 143  |
| Checking central pipe (Type 087 M and 087 N) . . . . .                      | 39 - 145  |
| Adjusting dampers (Type 087 M and 087 N) . . . . .                          | 39 - 146  |

## FIVE SPEED MANUAL TRANSMISSION 016 K

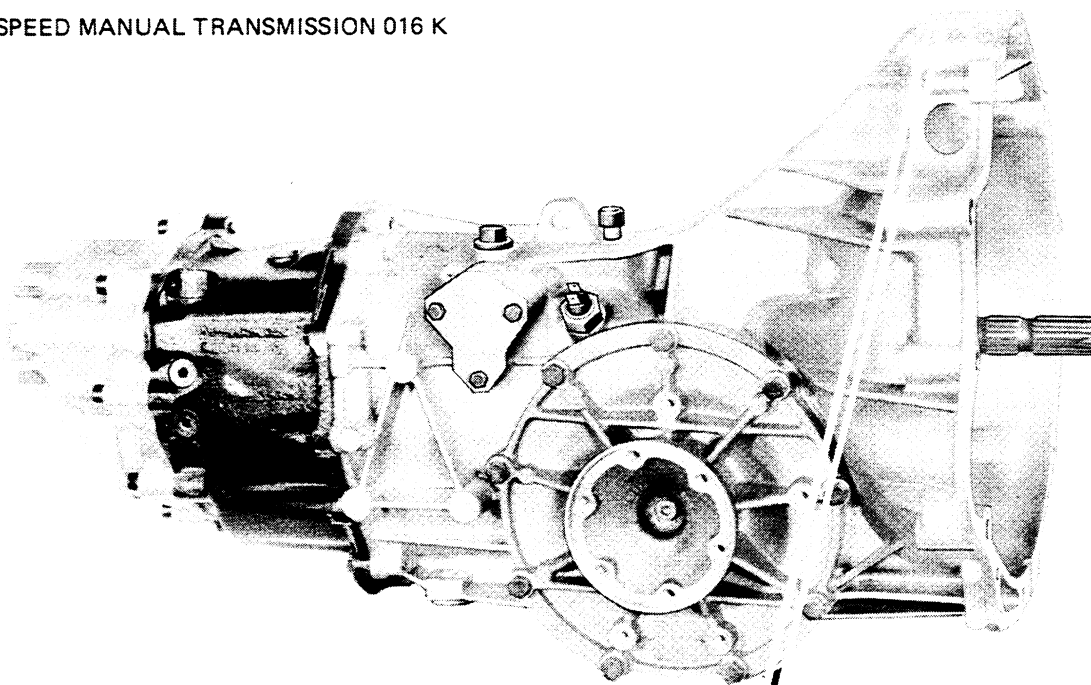

## Codes and Mfg. Date of Transmission

Example: QM 15 02 2

Code Day Month Year (1982)  
of Manufacture

Transmission Types Built Beginning With 1982 Model:

| Type  | Code | Installed in Cars for                     |
|-------|------|---|
| 016 K | QM   | Standard                                  |
| 016 K | 8 Q  | Optional (with limited slip differential) |

## 5-speed manual transmission 016J and 016K (as from Model 85/2)

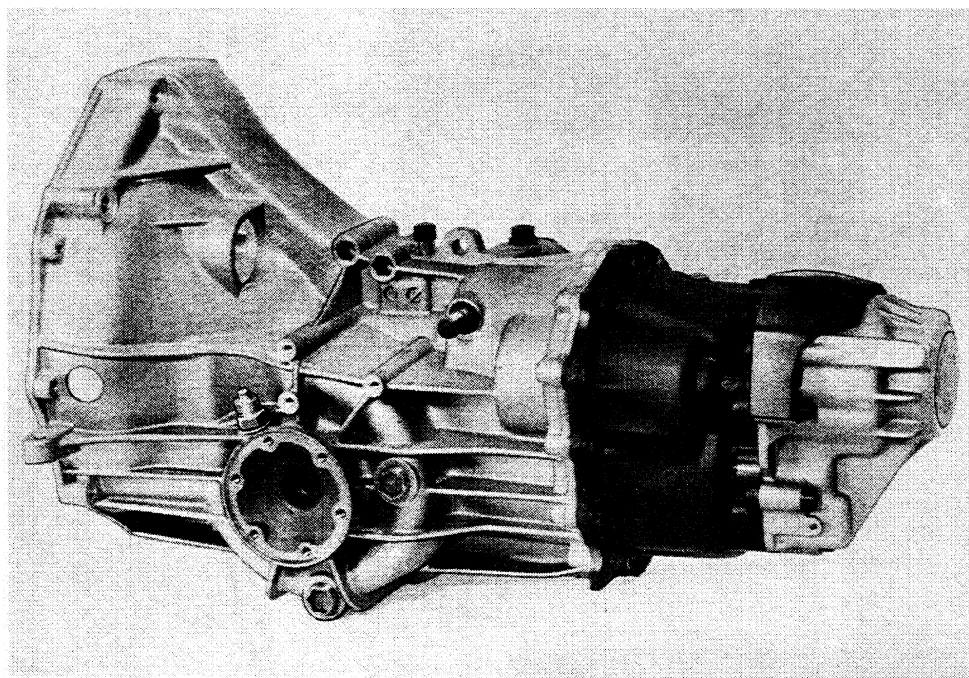

| Type  | Identification code | Equipment                                 | Installed in                   | Model year      |
|-------|---------------------|---|--------------------------------|-----------------|
| 016 J | 5Y                  | 5-speed without limited slip differential | Rest of the world<br>Worldwide | 85/2...88<br>88 |
| 016 J | 5Z                  | 5-speed with limited slip differential    | Rest of the world<br>Worldwide | 85/2...88<br>88 |
| 016 K | 5S                  | 5-speed without limited slip diff.        | USA/Japan                      | 85/2...87       |
| 016 K | 7V                  | 5-speed with limited slip diff.           | USA/Japan                      | 85/2...87       |
| 016 J | ASG                 | 5-speed without limited slip diff.        | Worldwide                      | 89...91         |
| 016 J | ASH                 | 5-speed with limited slip diff.           | Worldwide                      | 89...91         |

## FIVE-SPEED MANUAL TRANSMISSION 083 D FOR 944 S ('87 MODELS ONWARD)

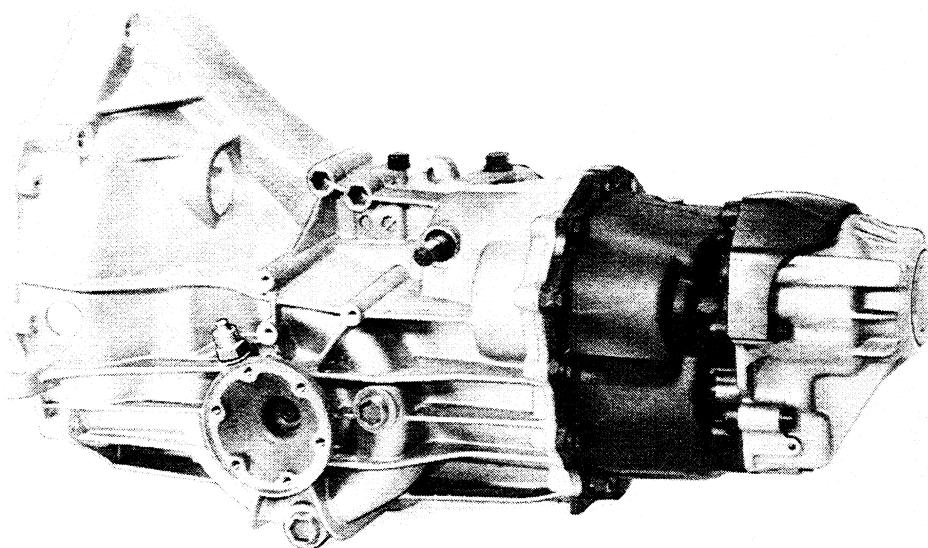

| Type  | Code | Installed in                               |
|-------|------|--|
| 083 D | AGP  | Worldwide                                  |
| 083 D | AGR  | Worldwide (with limited-slip differential) |

With the exception of a few modifications in its design and as regards repair the 083 D transmission is the same as the 016 R Turbo transmission.

The most important modifications are:

- no transmission-oil pump is available
- final drive ratio increased to 9 : 35
- transmission casing with machined recess for ring gear
- design distance "Ro" 58.15 mm

## Technical Data – Type 083 F

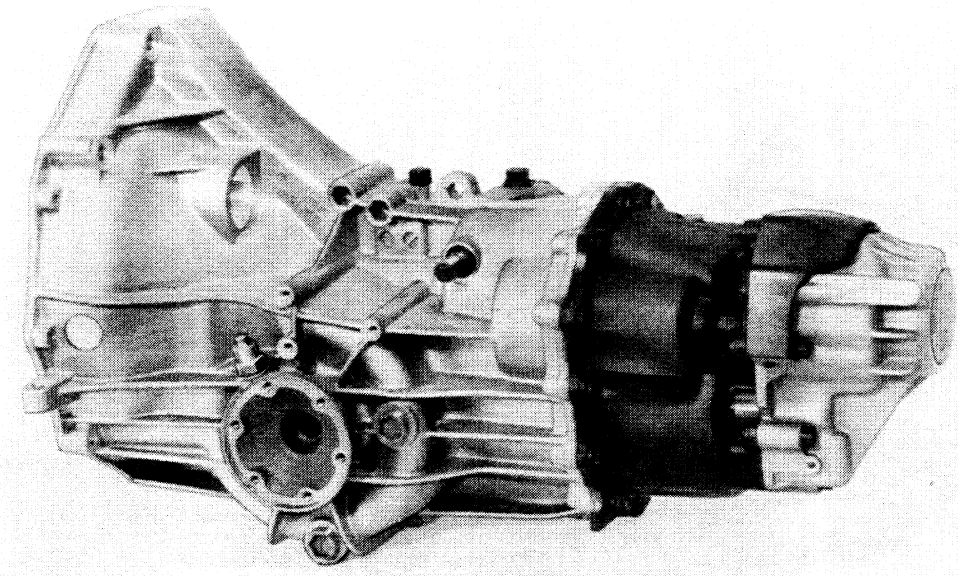

| Type  | Code | Equipment            | Installed in:                        | Model Year   |
|-------|------|----------------------|--------------------------------------|--------------|
| 083 F | A0S  | 5-speed without lock | 944 S 2 worldwide except Switzerland | 1989 / 90/91 |
| 083 F | A0T  | 5-speed with lock    | 944 S 2 worldwide except Switzerland | 1989 / 90/91 |
| 083 F | ASV* | 5-speed without lock | 944 S 2 Switzerland                  | 1989 / 90/91 |
| 083 F | ASW* | 5-speed with lock    | 944 S 2 Switzerland                  | 1989 / 90/91 |

\* with transmission enclosing and additional oil cooler .

Transmission 083 F is the same in design and repairing procedures as the 944 S transmission 083 D, except for a few deviations.

### Most Important Deviations:

- Longer 5th gear  $36 : 28 i = 0.778$
- Design distance "Ro" = 59.65 mm
- Final drive ratio  $8 : 31 i = 3.875$
- Stronger differential

|                     |   |                           |                 |           |
|---------------------|---|---------------------------|-----------------|-----------|
| <b>General Data</b> | <b>5 Speed Manual Transmission 083 F</b>  |                           |                 |           |
|                     | 016 J / 016K  |                           | 083 D (AGP/AGR) |           |
| <b>Ratios</b>       |   |                           |                 |           |
| 1st gear            | 10 : 36   | i = 3,6000                | 10 : 35         | i = 3.500 |
| 2nd gear            | 16 : 34   | i = 2,1250                | 17 : 35         | i = 2.059 |
| 3rd gear            | 24 : 35   | i = 1,4583                | 25 : 35         | i = 1.400 |
| 4th gear            | 28 : 30   | i = 1,0714                | 29 : 30         | i = 1.034 |
| 5th gear            | 35 : 29<br>(37 : 27)  | i = 0,8286<br>i = 0,7297) | 35 : 29         | i = 0.829 |
| Reverse gear        | 12 : 42   | i = 3,5000                | 12 : 42         | i = 3.500 |
| Final drive         | Hypoid pinion/ring gear with 12 mm offset   |                           |                 |           |
| Final drive ratio   | 9 : 35  | i = 3.889                 |                 |           |
| Power transmission  | Front-mounted engine and rear-mounted transmission connected via a pipe to form a bolted drive unit. Front-mounted engine, clutch, rotationally elastic shaft (25 mm dia.) running on 4 bearings in connecting pipe to the transmission, rear-mounted transmission bolted on final drive, double drive shafts to the rear wheels. |                           |                 |           |
| Filling capacity    | Approx. 2.0 liters hypoid transmission oil SAE 75 W 90 to API Class GL5 or MIL-L 2105 B, or SAE 80 to API Class GL 4 or MIL-L 2105 (refer to page 34 - 7)   |                           |                 |           |

USA values in parentheses

Rest of the world and USA vehicles have the same transmission ratio as from model 88.

## Technical Data – Type 083 F

| General Data       | 5 Speed Manual Transmission 083 F   |         |
|--------------------|---|---------|
| Ratios             |   |         |
| 1st gear           | 10 : 35   | = 3.500 |
| 2nd gear           | 17 : 35   | = 2.059 |
| 3rd gear           | 25 : 35   | = 1.400 |
| 4th gear           | 29 : 30   | = 1.034 |
| 5th gear           | 36 : 28   | = 0.778 |
| Reverse gear       | 12 : 42   | = 3.500 |
| Final drive        | Hypoid pinion/ring gear with 12 mm offset   |         |
| Final drive ratio  | 8 : 31  | = 3.875 |
| Power transmission | Front-mounted engine and rear-mounted transmission connected via a pipe to form a bolted drive unit. Front-mounted engine, clutch, rotationally elastic shaft (25 mm dia.) running on 4 bearings in connecting pipe to the transmission, rear-mounted transmission bolted on final drive, double drive shafts to the rear wheels. |         |
| Filling capacity   | Approx. 2.0 liters hypoid transmission oil SAE 75 W 90 to API Class GL5 or MIL-L 2105 B, or SAE 80 to API Class GL or MIL-L 2105 (refer to page 34 - 7).  |         |



### Torque specifications for manual transmission

| Location  | Description          | Threads | Material class | Tightening torque<br>Nm (ft.lb) |
|---|----------------------|---------|----------------|---------------------------------|
| Oil filler plug in transmission case              | Plug                 | M 24    | -              | 24 (17)                         |
| Oil drain plug in transmission case               | Plug                 | M 24    | -              | 24 (17)                         |
| Gear shift shaft cover to transmission case       | Hexagon head screw   | M 6     | 8.8            | 8 (6)                           |
| End shield to transmission case                   | Hexagon head screw   | M 8     | 8.8            | 24 (17)                         |
| Ball bearing to input shaft                       | Hexagon head screw*  | M 10    | 8.8            | 70 (51)                         |
| Cover to end shield                               | Fillister head screw | M 8     | 8.8            | 24 (17)                         |
| 5th gear wheel to pinion                          | Hexagon head screw*  | M 10    | 8.8            | 70 (51)                         |
| Shift lock to end shield and transmission housing | Threaded bushing     | M 18    | -              | 30 (22)                         |
| Shift travel stop to end shield                   | Stop screw           | M 14    | 8.8            | 30 (22)                         |

\* Screws are microencapsulated. Must only be used once.

| Location                                     | Description                         | Thread | Material class | Tightening torque<br>Nm (ft.lb) |
|--|-------------------------------------|--------|----------------|---------------------------------|
| Reversing lever to end shield                | Cross-recessed fillister head screw | M 10   | 8.8            | 35 (25)                         |
| Reverse gear bolt to end shield              | Hexagon head screw with collar      | M 8    | 8.8            | 24 (17)                         |
| Stub shaft to differential                   | Screw                               | M 8    | 8.8            | 24 (17)                         |
| Side transmission cover to transmission case | Hexagon head screw                  | M 8    | 10.9           | 24 (17)                         |
| Ring gear to differential case               | Hexagon head screw                  | M 10   | 12.9           | 90 (66)                         |
| Back-up light switch to transmission case    | Switch                              | M 18   | -              | 42 (42)                         |
| Speedometer bushing to transmission case     | Speedometer bushing                 | M 18   | -              | 42 (30)                         |
| Crankshaft to flange                         | Hexagon socket screw                | M 8    | 12.9           | 42 (30)                         |

| General Data   | Clutch  |
|----------------|---|
| Design         | Single plate, dry clutch with diaphragm springs, pull release version, located on engine, hydraulic operation |
| Pressure plate | MFZ 225 contact pressure 6100 – 6800 N (1370 – 1530 lb)   |
| Clutch disc    | 225 GUD (with rubber torsion damper)  |

TIGHTENING TORQUE FOR CLUTCH, CENTRAL TUBE, TRANSMISSION SUSPENSION AND SHIFT LINKAGE

| Location  | Description | Threads   | Material | Torque<br>Nm (ft lb) |
|---|-------------|-----------|----------|----------------------|
| <b>CLUTCH</b>   |             |           |          |                      |
| Guide sleeve on clutch housing                              | Bolt        | M 7       | 8.8      | 15 (11)              |
| Clutch and gear ring installation                           | Bolt        | M 8       | 8        | 25 (18)              |
| Flywheel to crankshaft                                      | Bolt        | M 10      | 10.9     | 90 (65)              |
| Clutch housing to engine                                    | Bolt        | M 12      | 8.8      | 75 (54)              |
| Guard and support to clutch housing and crankcase           | Bolt        | M 10      | 8.8      | 42 (30)              |
| Release lever shaft with clutch housing                     | Bolt        | M 6 x 35  | 8.8      | 9.5 (7)              |
|   | Nut         | M 6       | 8        | 7.5 (6)              |
| Reference mark and speed sensors to holder                  | Bolt        | M 6       | 8.8      | 8 (6)                |
| Slave cylinder to clutch housing                            | Bolt        | M 8 x 28  | 8.8      | 21 (15)              |
| Master cylinder to firewall                                 | Nut         | M 8       | 8        | 21 (15)              |
| Clutch tube to clutch hose or to master and slave cylinders | Coupling    | M 12      |          | 16 (11)              |
| Drive shaft to transmission input shaft                     | Clamp bolt  | M 10 x 46 | 12.9     | 80 (58)              |
| Central tube flange to clutch housing                       | Bolt        | M 10 x 35 | 8.8      | 42 (30)              |

| Location   | Description     | Threads   | Material    | Torque in Nm (kpm) |
|--|-----------------|-----------|-------------|--------------------|
| Central tube housing to transmission case                | Bolt            | M 12 x 75 | 10.9        | 85 (8.5)           |
|  |                 | M 12 x 80 | 10.9        | 85 (8.5)           |
|  |                 | M 10 x 60 | 8.8         | 42 (4.2)           |
| <b>TRANSMISSION SUSPENSION (Double Point Suspension)</b> |                 |           |             |                    |
| Transmission mount to body                               | Bolt            | M 10      | 8.8         | 46 (4.6)           |
| Mount to bracket   | Bolt            | M 8       | 8.8         | 25 (2.5)           |
| Bracket to transmission                                  | Bolt            | M 8       | 10.9        | 25 (2.5)           |
| <b>TRANSMISSION SUSPENSION (Single Point Suspension)</b> |                 |           |             |                    |
| Transmission carrier to body                             | Bolt            | M 10      | 8.8         | 46 (4.6)           |
| Transmission mount to transmission carrier               | Bolt            | M 8       | 8.8         | 23 (2.3)           |
| Bracket to transmission mount                            | Bolt            | M 8       | 8           | 23 (2.3)           |
| Bracket to transm.                                       | Bolt            | M 8       | 8           | 23 (2.3)           |
| <b>SHIFT</b>   |                 |           |             |                    |
| Joint rod to transmission case                           | Ball-ended bolt | M 8       | 9 S Mn 28 K | 14 (1.4)           |
| Joint rod to intermediate shift lever                    | Nut             | M 8       | 8.8         | 21 (2.1)           |
| Shift rod  | Bolt            | M 8       | 9 S Mn 28 K | 21 (2.1)           |
| Shift lever plate to central tube                        | Bolt            | M 8 x 12  | 8.8         | 21 (2.1)           |
| Intermediate shift lever to shift shaft                  | Bolt            | M 8       |             | 22.5 (2.25)        |

## CHECKING CLUTCH PLAY

Automatic hydraulic clutch adjustment means that clutch play cannot be checked at the clutch pedal.

Nevertheless, the clutch cannot operate correctly unless there is 0.5 mm clearance between push rod and master-cylinder piston.

This play cannot be measured; it is about 3 mm at the pedal pad and must be determined by feel.

If necessary, correct play by adjusting piston rod.

## ADJUSTING CLUTCH SPRING

A spring which reduces the pedal force is installed to assist the force applied to the pedal. For this purpose, the spring must be preloaded accordingly.

Measure distance A between outer edge of plate and bearing with clutch engaged (clutch pedal at end stop).

- Distance A for green color-coded spring (no longer available as spare part) 60 mm (75 mm\*)
- Distance A for blue color-coded spring (increased spring rate/in use since February 1986) = 55 mm (68 mm\*)

If necessary, correct by turning the hex nut.

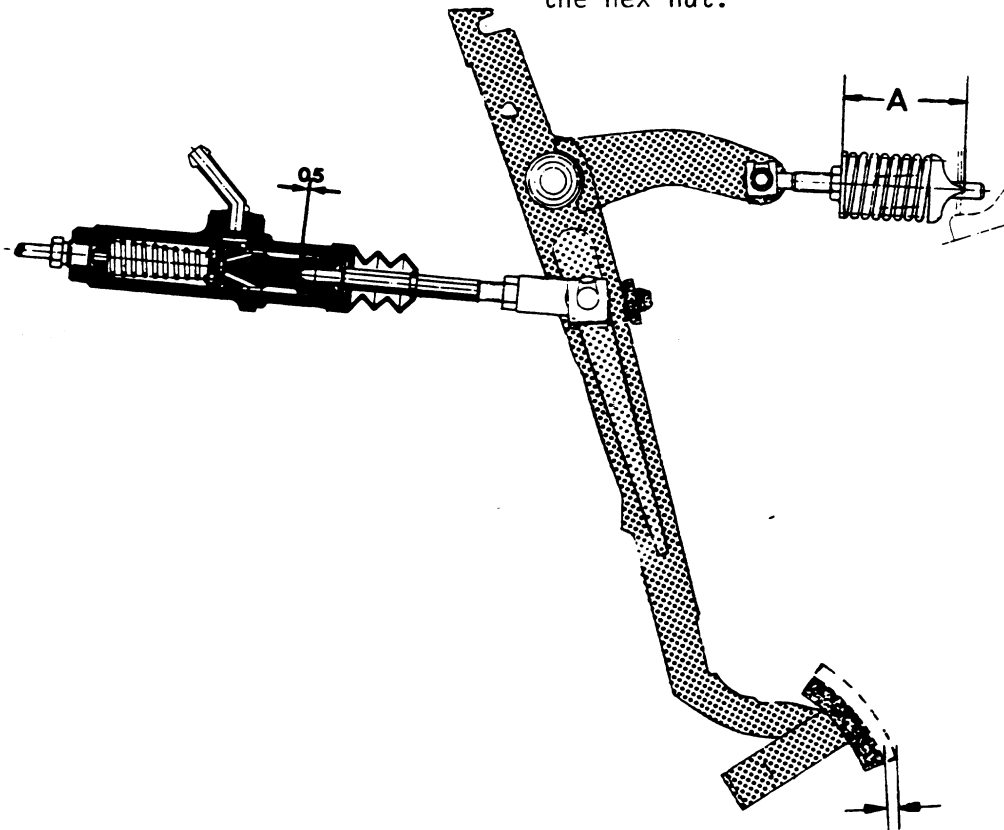

\* Values of distance A in parentheses apply to spring when removed. Reassemble servospring/guide rod with assembly wire (3 mm dia. split pin).

## CHECKING CLUTCH DRIVE PLATE FOR WEAR

Checking

Remove cap

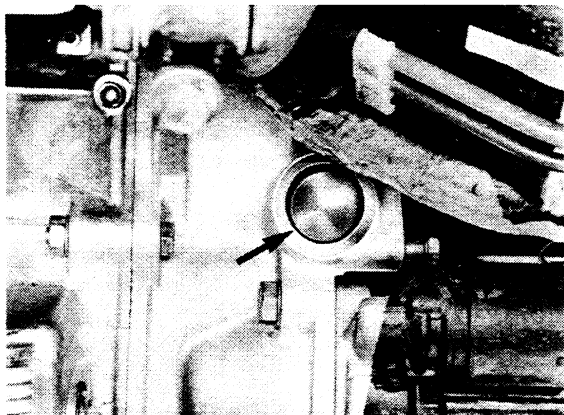
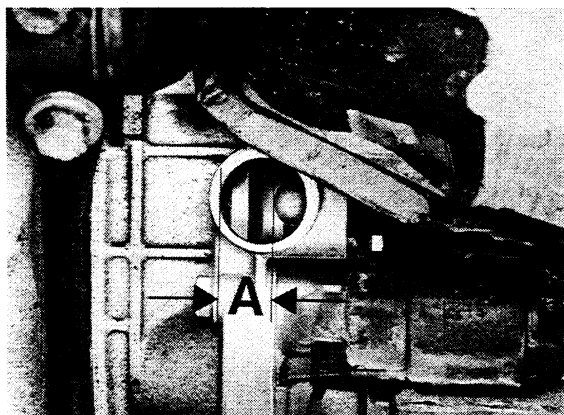
Measure distance "A" with  
a suitable gage

|            |       |
|------------|-------|
| Size new   | 18 mm |
| Wear limit | 34 mm |

## CHECKING RELEASE TRAVEL

1. Remove cap (see page 30 - 2).
2. Measure distance "B" with a suitable measuring tool.

- 1 Clutch slave cylinder  
 2 Push rod  
 3 Release lever  
 B Release travel  
 Nominal value =  
 15 to 18 mm

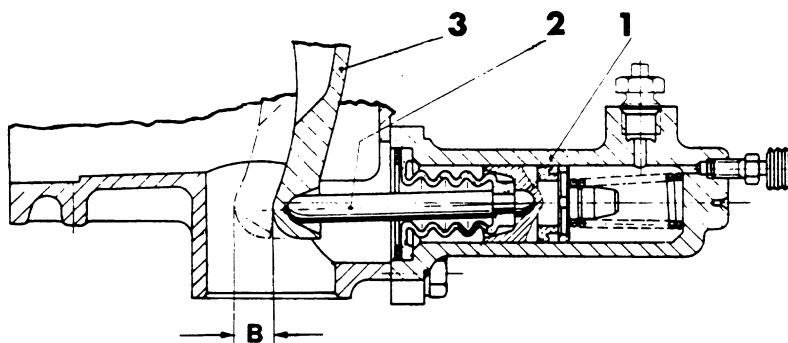

If distance is less than 15 mm there can be no guarantee that clutch disengages fully.

- Possible Causes:
- air in hydraulic system
  - clutch master and/or slave cylinders defective (cups)
  - no or insufficient clutch play
  - limited clutch pedal travel (e. g. bunched-up floor mats)

## BLEEDING CLUTCH

## General Information

The use of a pressure bleeder is recommended.

1. Fill tank with brake fluid to upper edge. Remove restrictor sleeve. Connect bleeder.
2. Switch on bleeder and open bleeder screw on clutch slave cylinder until escaping fluid is without air bubbles. Operate clutch pedal several times during this step.
3. If necessary because of residual air (release travel less than 15 mm), unscrew slave cylinder on clutch housing. Push rod against stop in slave cylinder and release again (bleeder switched off, brake fluid tank not filled to upper edge). This will force the residual air back into the clutch line or master cylinder/ brake fluid tank.

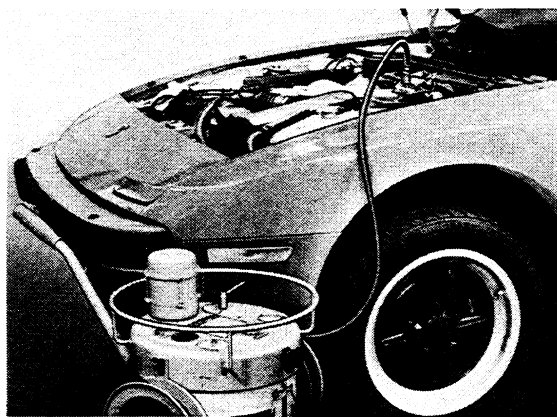

## Note

Never operate clutch pedal as long as slave cylinder is removed.



4. Install slave cylinder again.  
Repeat bleeding procedures.
- 
- 

## REMOVING AND INSTALLING CLUTCH

**Note**

When performing operations on the transaxle system that involve rotating or shifting the transaxle tube, always wear leather gloves to avoid injuries.

## R e m o v i n g

1. Disconnect ground wire at battery. Disconnect ground wire connecting body with clutch housing.

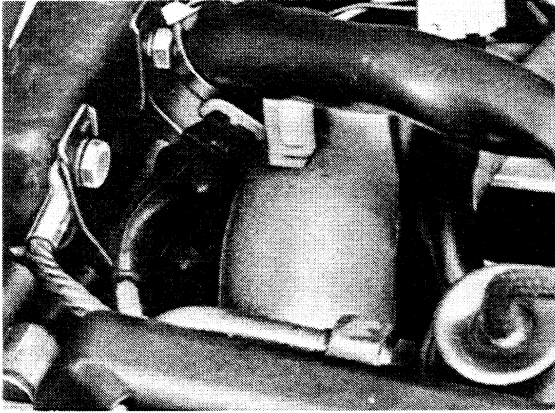

2. Disconnect ground wire on clutch housing I. Unscrew socket head bolts and run reference mark sensor II and speed sensor III for DEE out of holder IV. Disconnect wire harness for starter at upper mounting point V. If necessary, remove air cleaner for this step.

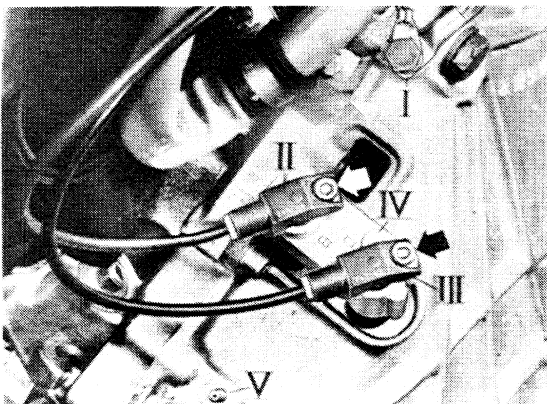

3. Remove exhaust assembly. This requires unscrewing exhaust pipe on exhaust manifold and suspension mounting bolts. If car has oxygen control, disconnect wires of oxygen sensor on plug.

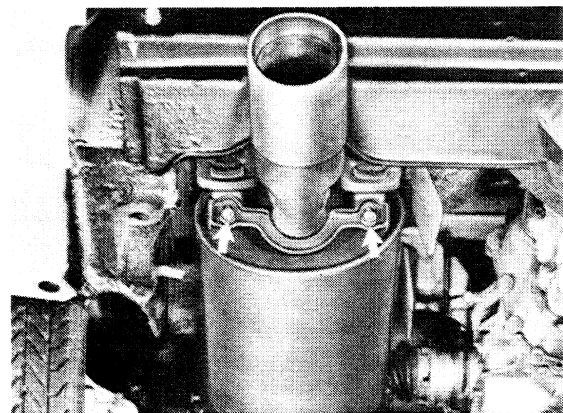
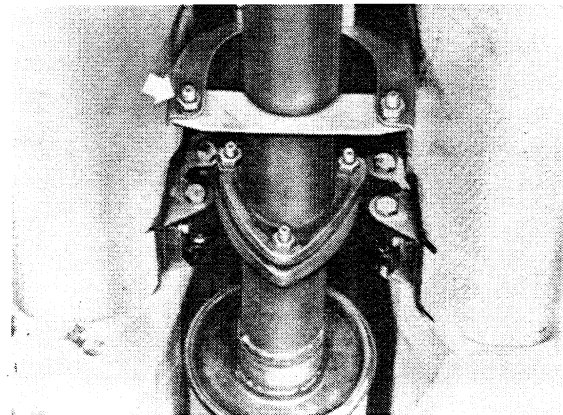
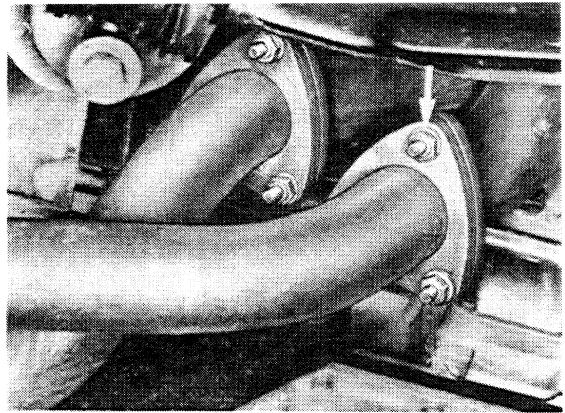

4. Remove heat shield above catalytic converter. Remove splash guard. Run out rear exhaust pipe bracket together with bracket bolted on the central tube.

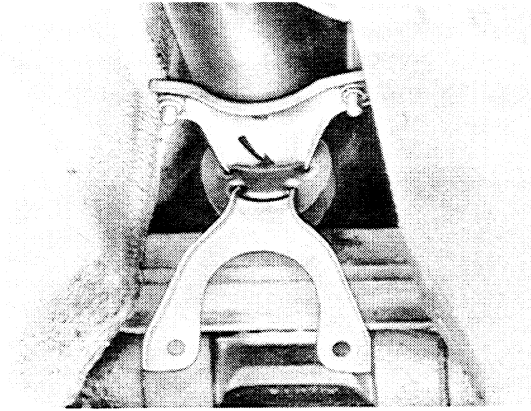
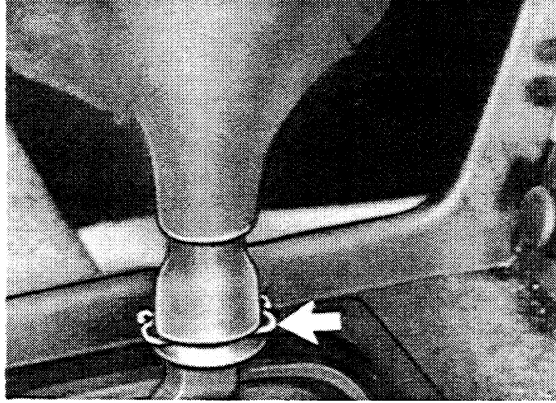

5. Push back dust cover. Remove lockwire on clamp bolt of selector linkage. Unscrew bolt.

7. Remove circlip on shift lever. Pull off selector rod and washer on bolt of shift lever.

8. Remove insulator above shift lever console. Remove shift lever, but first mark location of console after removing the rear mounting bolt.

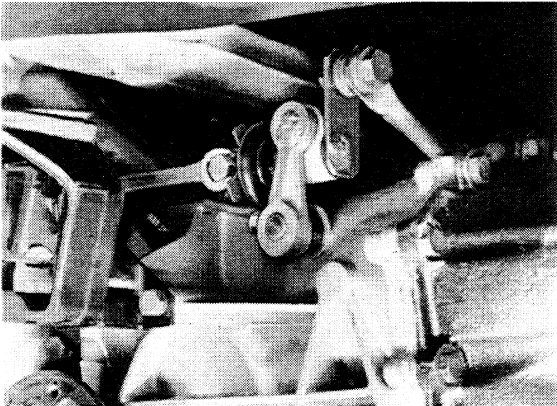

9. Press down on insulation sheet and push selector rod forward in cavity by about 300 mm (12 in.).

6. Lift and fold down dust cover and sleeve on shift lever. Remove shift lever knob retainer. Take off shift lever knob.

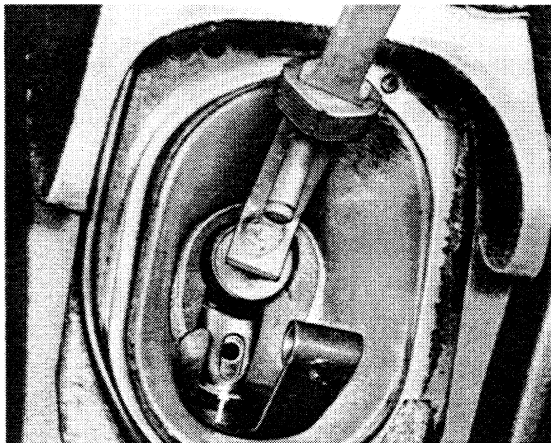

10. Unscrew two upper mounting bolts of clutch housing.

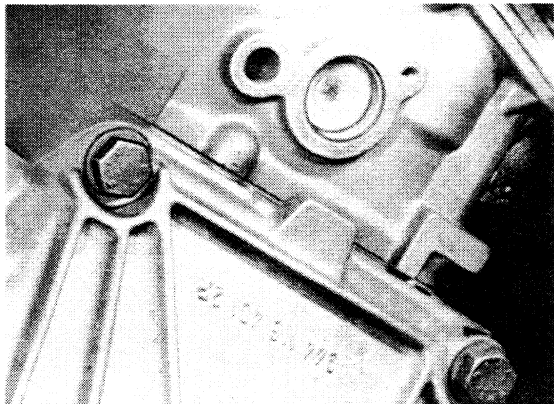

11. Take off end cap on central tube housing. Push back protective tube for selector rod far enough, that it is outside of the central tube housing. This is done by inserting a large screwdriver through assembly opening in central tube housing and opening retainer on protective tube.

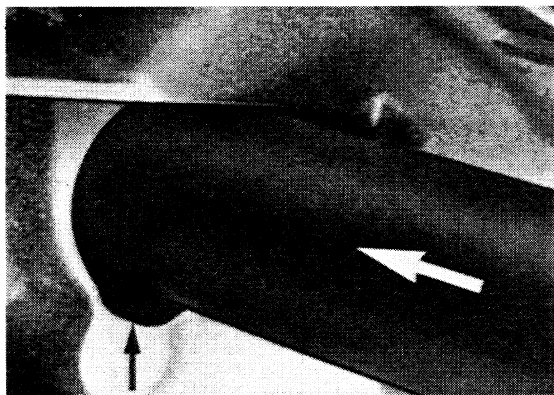

12. Unscrew and remove clamping sleeve bolts through assembly openings. Push clamping sleeve in direction of transmission.

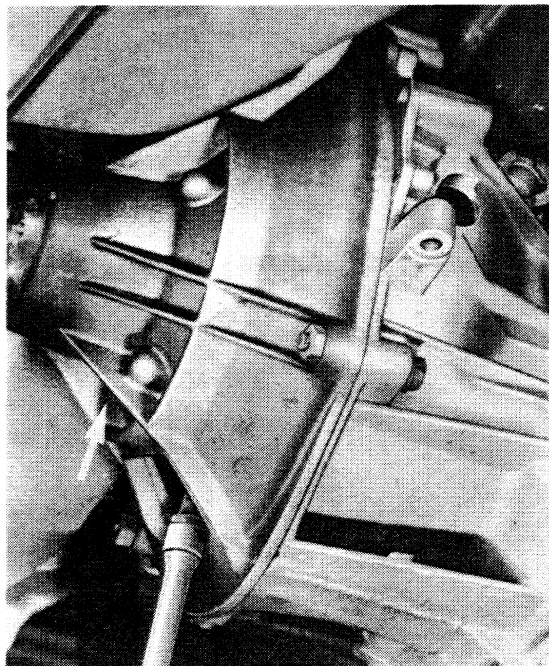

13. Detach joint shafts on transmission end, but do not let joint shafts hang down to final stop in joint (instead suspend from car with wire) to avoid damage.
14. Pull off wires on backup light switch. Also pull off plug on speedometer drive of cars since 1985/2 models (see page 34 - 4).

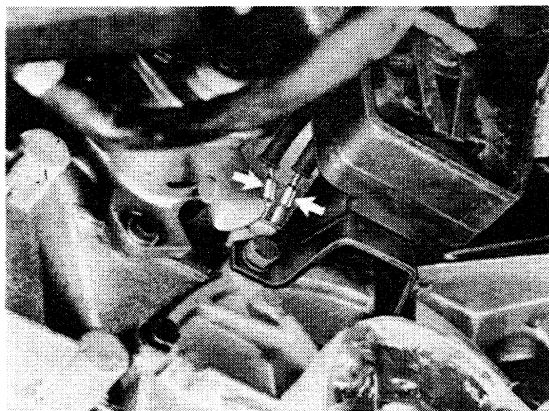

15. Run in a workshop trolley jack fitted with Special Tool 9115 or an universal transmission jack underneath the transmission. Lift transmission slightly to remove pressure on suspension.

16. Remove transmission suspension bolts.

#### Initial Version

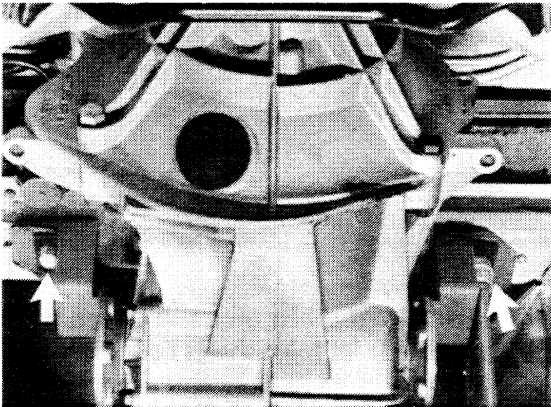

#### Present Modified Version

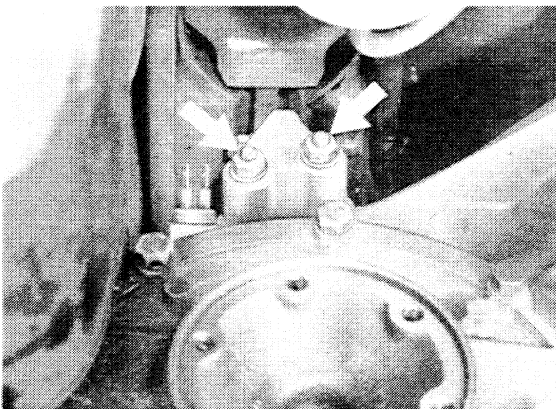

17. Lower transmission with central tube until central tube rests on the rear axle cross tube.

18. Remove transmission/central tube flange bolts. Remove transmission downward.

19. Remove starter. Unscrew clutch line mounting clamp. Detach clutch slave cylinder on clutch housing (do not open hydraulic system).

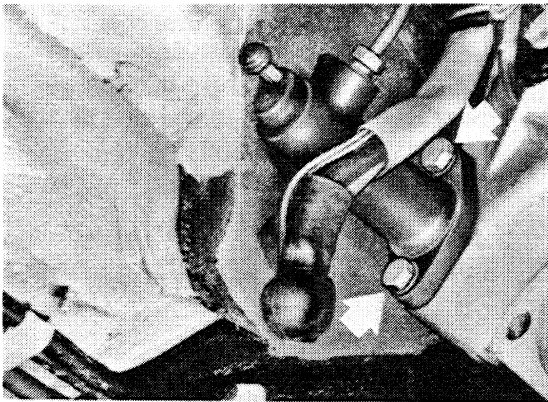
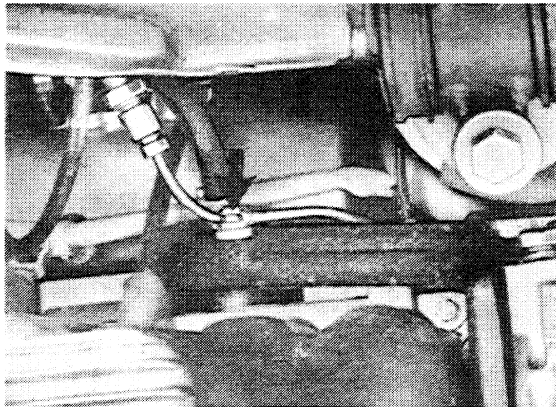

20. Disconnect starter wire harness on clutch housing. Pull out release lever shaft mounting bolt with a 8 mm bolt. Unscrew the four central tube/clutch housing mounting bolts.

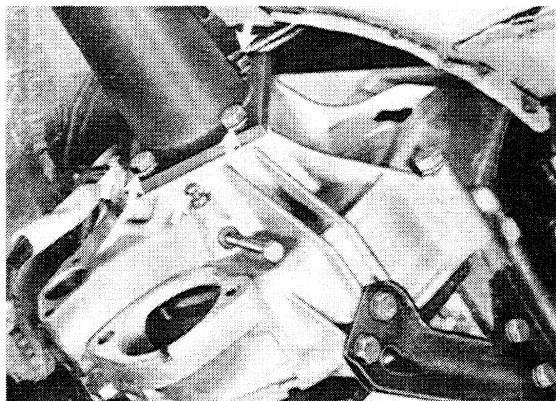



21. Pull back selector rod again, which had been pushed forward for removal of the transmission, so that nothing will be damaged when moving the central tube.

22. Move back central tube far enough until central tube housing rests on transmission carrier. If central tube cannot be moved out of clutch housing without applying force, hold engine tight with transport eye mounted on camshaft housing with Special Tool VW 10-222.

In this case the engine has excessive inclination at rear — check engine suspension.

#### Note

Make sure brake lines are not damaged by the central tube.

23. Unscrew guard on clutch housing. Remove right support, insofar as car is fitted with supports.

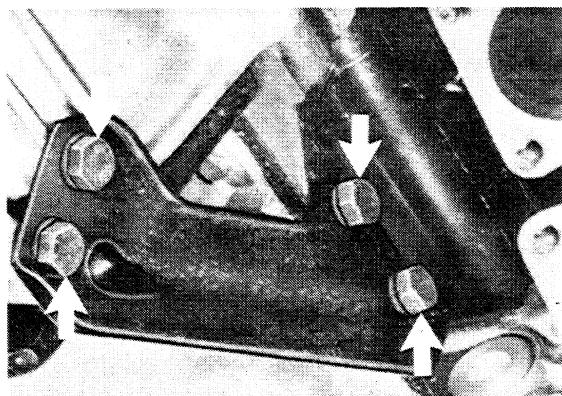

24. Unscrew two lower mounting bolts on clutch housing, after unscrewing engine mount nuts and pushing engine to the right.

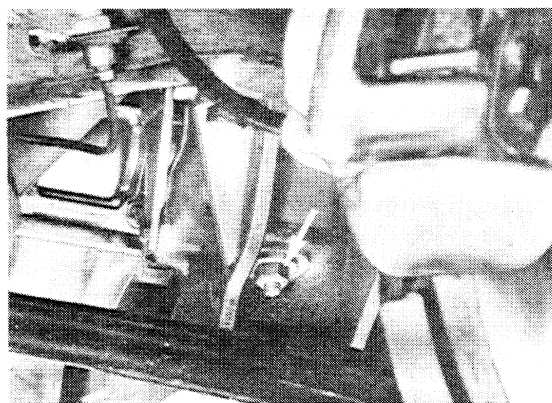
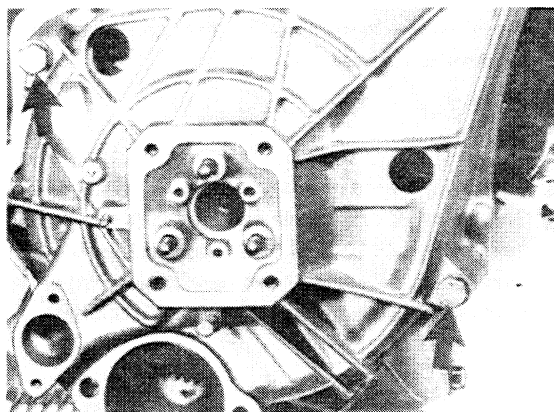

25. Move out guard and clutch housing with release lever.

26. Disconnect clutch on flywheel.

## Installing

1. Check flywheel, starter gear ring, pilot bearing in flywheel, crankshaft seal, release bearing, guide sleeve, release lever, pressure plate and clutch disc for wear or damage.
2. Coat guide sleeve with multi-purpose MoS<sub>2</sub> grease. Give spline of drive shaft and area in pilot bearing/flywheel a light coat of MoS<sub>2</sub>. Lubricate release lever (pivot, ball socket and needle bearings) with white solid lubricating paste AOS 126 0006.
3. Install clutch. This requires that friction surfaces be clean and without grease. Use short drive shaft of a 928 (or a shortened drive shaft from a damaged central tube) to center the clutch disc. Screw in bolts uniformly crosswise. Tightening torque = 25 Nm (18 ft lb). Counterhold on hexagon bolt of front pulley.

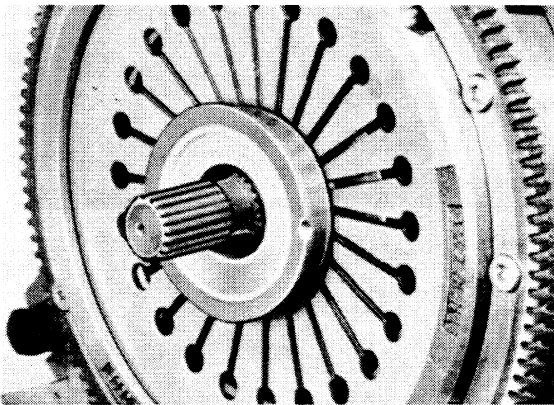

4. Mount clutch housing and release lever together on engine/release bearing.  
This requires that the bolt glued on the flywheel for the reference mark sensor faces down (danger of damage).  
Insert cover. Mount clutch housing with the two lower bolts.
5. Move release lever until needle bearing and bore in clutch housing align. Slide in release lever shaft positioned correctly so that machined surface faces mounting bolt against stop. If necessary, move release lever back and forth – but never use force!

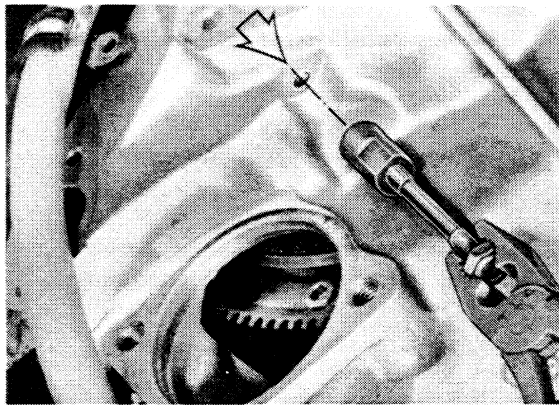

6. Screw in mounting bolt for a correctly installed release lever shaft and lock with nut.
7. Bolt clutch housing, cover and, if applicable, right support. Connect starter wire harness. Mount start and reference mark sensors as well as ground wires on clutch housing and body.

8. Check that insulation sheet on central tube is still positioned correctly. Distance from flange inside to insulation should be 500 mm (20 in.).

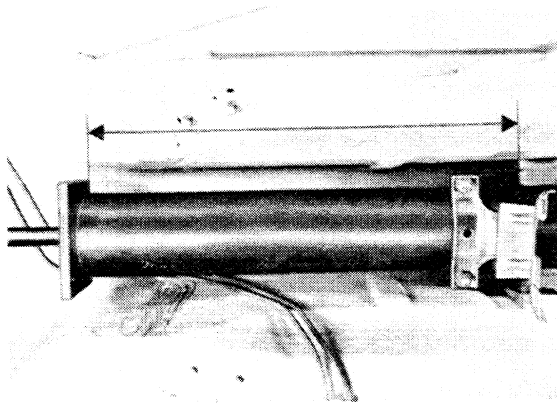

9. Push central tube forward and bolt on clutch housing. Guide central tube with drive shaft into clutch housing and clutch disc carefully (danger of damage). Never apply force. Screw in mounting bolts and loosen again by about 1 turn. (Never tighten bolts fully, see note!)

#### Note

To avoid tension in engine, transmission and central tube, when installing in car tighten central tube to clutch housing mounting bolts only after bolting the engine and transmission.

10. Install clutch slave cylinder. Mount clutch line.

11. Place selector rod protective tube in transmission case. Replace a selector rod protective tube, if retainer is deformed excessively. Install transmission. Push selector rod protective tube forward until retainer engages in transmission case. Mount selector rod on intermediate shift lever.

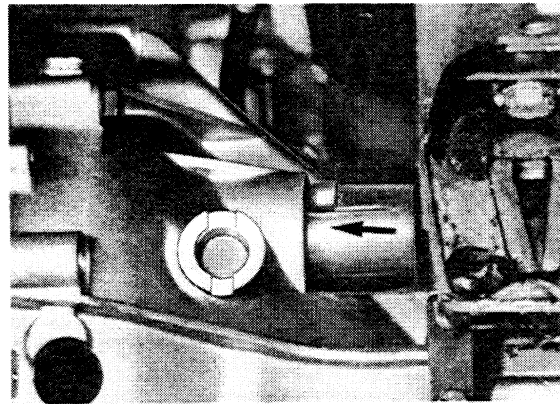

12. Tighten mounting nuts insofar as engine mounted had been unscrewed. Then bolt central tube on clutch housing to specified torque (bolts had only been screwed in finger tight, see point 9).

13. Repair any damage on splash guard caused by removal of transmission or moving of central tube. Install starter and exhaust assembly.



14. Mount shift lever so that inclination in neutral is  $85^\circ$  (refer to mark).

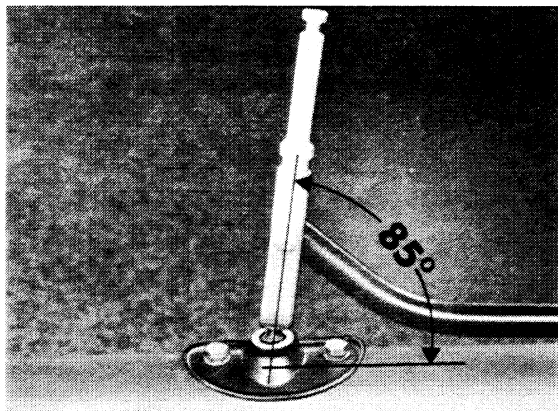

DISASSEMBLING AND ASSEMBLING CLUTCH CONTROLS

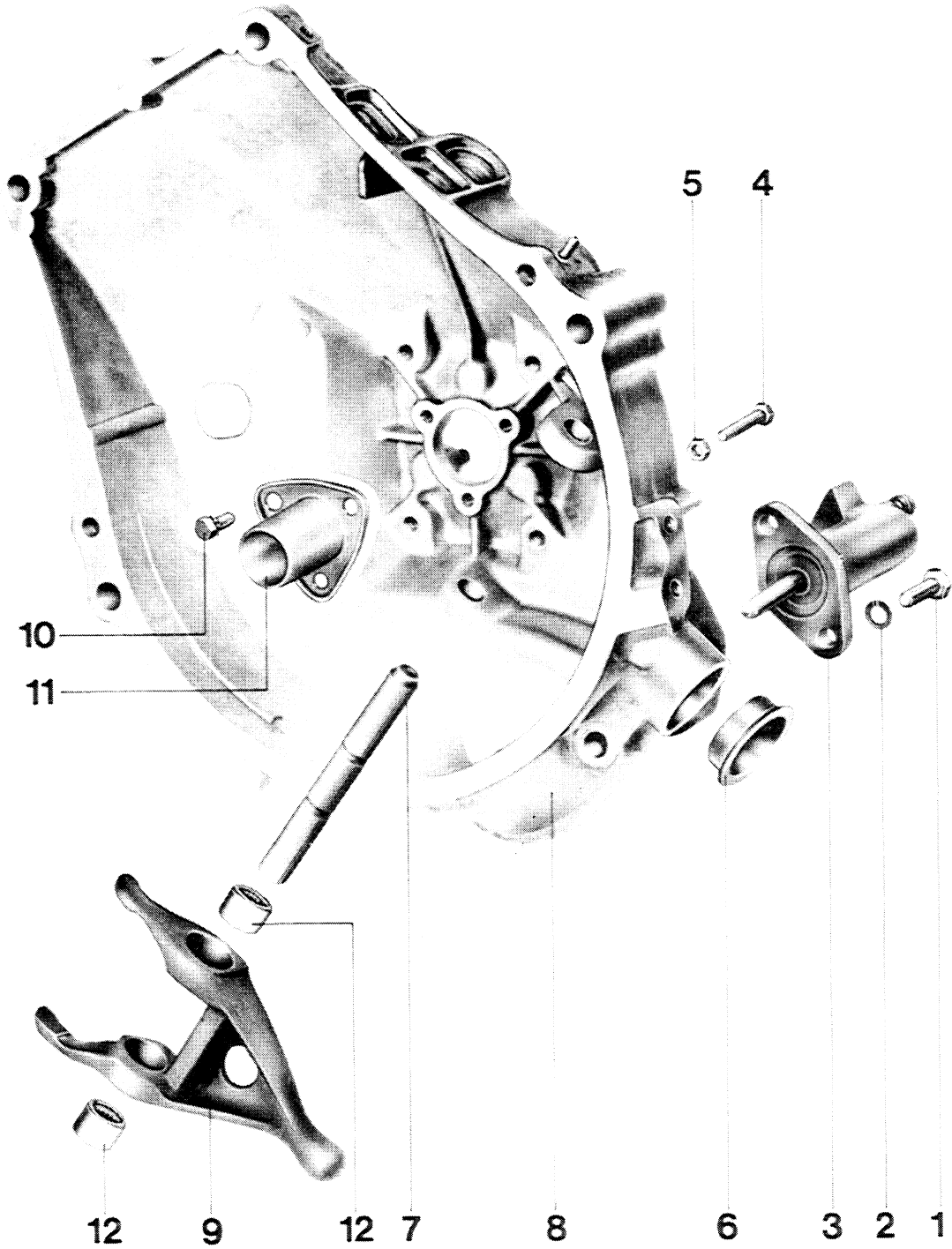

| No. | Description         | Qty. | Note When:   |  | Special Instructions  |
|-----|---------------------|------|--|--|---|
|     |                     |      | Removing   | Installing   |   |
| 1   | Bolt                | 2    |  | Torque: 21 Nm<br>(15 ft lb)  |   |
| 2   | Lockwasher          | 2    |  | Replace, if necessary  |   |
| 3   | Slave cylinder      | 1    | Do not operate clutch pedal after removing cylinder (line connected) |  |   |
| 4   | Bolt 6 x 35         | 1    |  | Tighten after pushing in release lever shaft correctly   | Refer to point 8  |
| 5   | Nut (locknut)       | 1    |  |  |   |
| 6   | Cap                 | 1    |  |  |   |
| 7   | Release lever shaft | 1    | Pull out with a 8 mm bolt (stud)                                     | Push in against stop in correct position – machined surface faces bolt 4   | Refer to point 8. Do not use force! Move release lever back and forth slightly through sight hole |
| 8   | Clutch housing      | 1    |  | Mount clutch housing and release lever together on engine/ release bearing before installing release lever shaft |   |
| 9   | Release lever       | 1    |  | Lubricate bearing surfaces with a white solid lubricating paste (AOS 126 0006)                                   |   |

| No. | Description    | Qty. | Note When: |   | Special Instructions |
|-----|----------------|------|------------|---|----------------------|
|     |                |      | Removing   | Installing  |                      |
| 10  | Bolt           | 3    |            | Torque: 9.5 Nm<br>(7 ft lb)   | Check for wear       |
| 11  | Guide sleeve   | 1    |            | Coat sliding surfaces with multi-purpose grease MoS <sub>2</sub>                                    |                      |
| 12  | Needle bearing | 2    |            | Press in flush with a suitable mandrel. Lubricate with white solid lubricating paste (AOS 126 0006) |                      |

## CHECKING DRIVE PLATES

1. Inspect splines. Drive plate must slide easily on input shaft in axial direction without radial play.
2. Check rivets and rubber torsion damper for cracks or damage. Replace drive plate when in doubt.
3. Inspect clutch liners. If clutch liners are covered with oil, burnt, damaged or worn at spots, install a new drive plate.
4. Check liner thickness of drive plates.  
Drive plate with riveted liner:  
Relaxed thickness:  $8.1 \pm 0.3$  mm.  
Relaxed wear limit: 6.3 mm for symmetrical wear.

## Note

Clutch liners cannot be replaced.

5. Check drive plate with liner for lateral runout.  
Max. permissible lateral runout 0.6 mm measured approx. 2 to 3 mm from outside diameter.
-

## CHECKING DRIVE PLATES

1. Inspect splines. Drive plate must slide easily on input shaft in axial direction without radial play.
2. Check rivets and rubber torsion damper for cracks or damage. Replace drive plate when in doubt.
3. Inspect clutch liners. If clutch liners are covered with oil, burnt, damaged or worn at spots, install a new drive plate.
4. Check liner thickness of drive plates.  
Drive plate with riveted liner:  
Relaxed thickness:  $8.1 \pm 0.3$  mm.  
Relaxed wear limit: 6.3 mm for symmetrical wear.

### Note

Clutch liners cannot be replaced.

5. Check drive plate with liner for lateral runout.  
Max. permissible lateral runout 0.6 mm measured approx. 2 to 3 mm from outside diameter.

OVERHAULING CLUTCH SLAVE CYLINDER

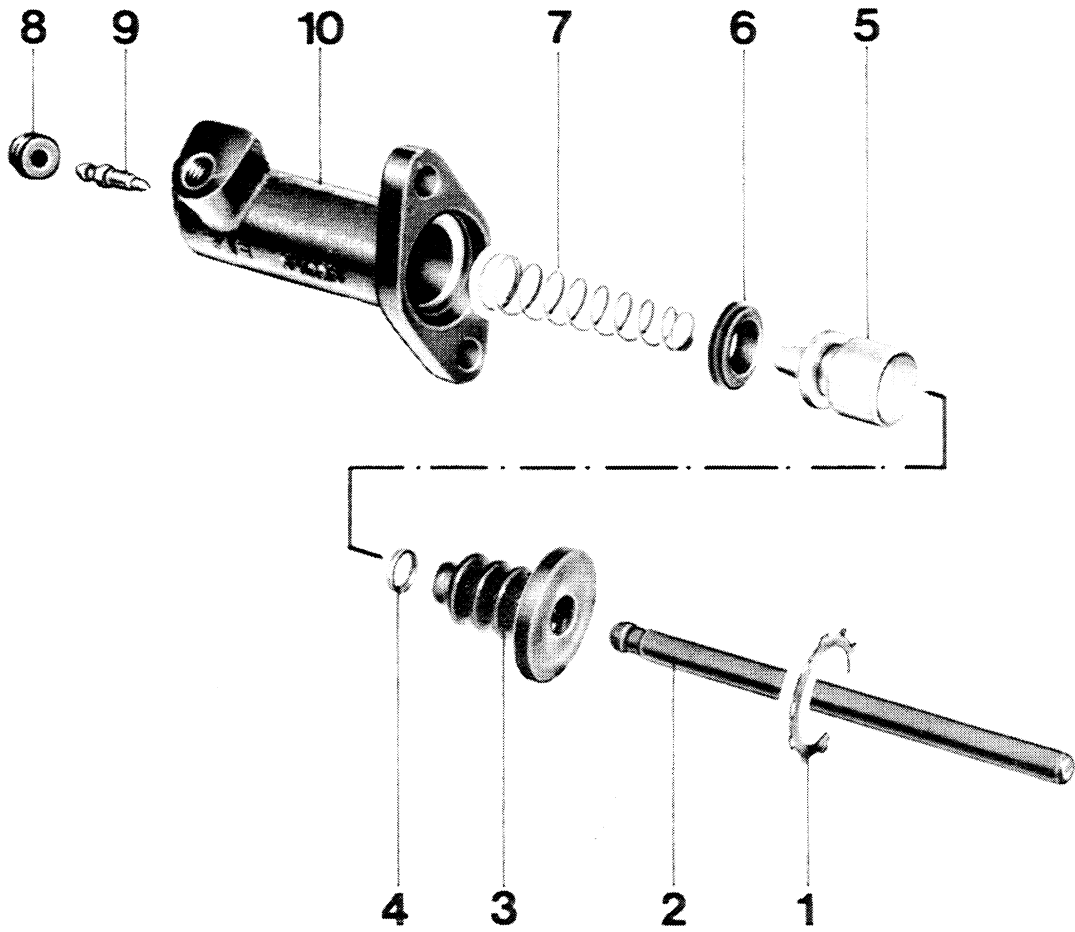

| No. | Description           | Qty. | Note When: |  | Special Instructions |
|-----|-----------------------|------|------------|--|----------------------|
|     |                       |      | Removing   | Installing   |                      |
| 1   | Circlip               | 1    |            | Replace, curved surface faces in. Make sure of perfect fit                               |                      |
| 2   | Push rod              | 1    |            |  |                      |
| 3   | Rubber cover          | 1    |            | Replace  |                      |
| 4   | Retainer              | 1    |            |  |                      |
| 5   | Piston                | 1    |            |  |                      |
| 6   | Cup                   | 1    |            | Replace, apply very thin coat of brake cylinder paste                                    |                      |
| 7   | Spring                | 1    |            | Position correctly   |                      |
| 8   | Dust cap              | 1    |            |  |                      |
| 9   | Bleeder screw         | 1    |            |  |                      |
| 10  | Clutch slave cylinder | 1    |            | Always clean with alcohol, apply very thin coat of brake cylinder paste in cylinder bore |                      |



## CHECKING TORQUE CONVERTER

1. Converter identification on lug:

K = USA/Japan

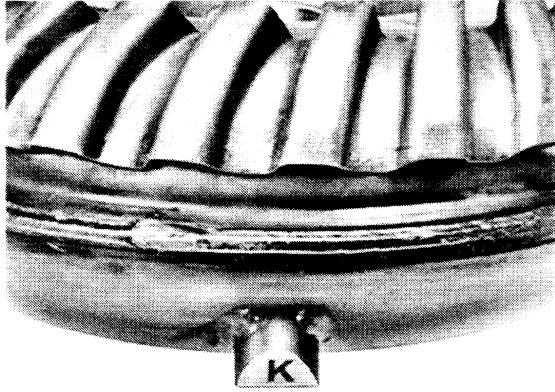

2. Check hub of converter for signs of scoring (arrow).

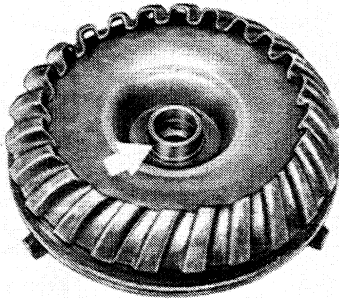

3. Check free movement of turbine with the turbine shaft inserted.

4. Check bearing sleeve visually for damage, measuring with an internal calipers if necessary.

Wear limit = max. 34.25 mm dia.

Out-of-round = max. 0.03 mm

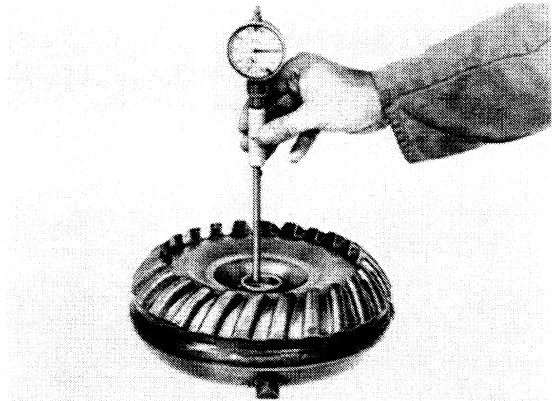

**Note :**

The torque converter is a welded part and must be replaced as a complete unit when damaged.

## DRAINING TORQUE CONVERTER

Drain the torque converter when ATF has abrasive particles or for a general overhaul.

1. Place converter at slight angle.
2. Connect a suitable hose (max. outside dia. 8 mm and small as possible inside diameter) on a plastic suction bottle (2 liter/2 US qt capacity).
3. Squeeze plastic bottle slightly and insert free end of hose into converter hub until it touches bottom.
4. Release the bottle so that the vacuum effect will draw in the ATF.
5. Unscrew the cap slightly as soon as the ATF runs to avoid pressure in the bottle.

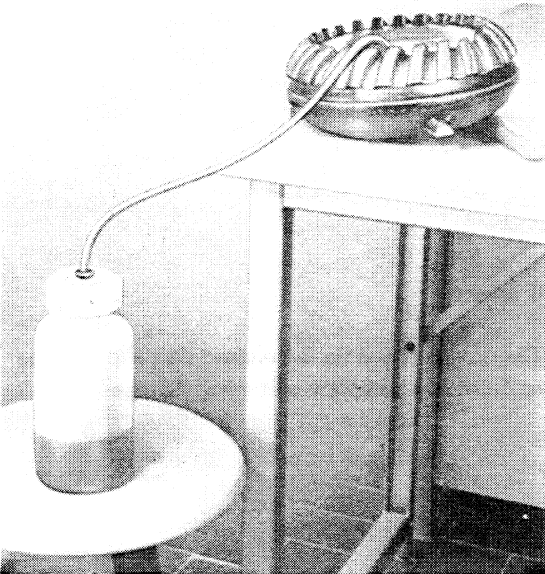

3. Squeeze plastic bottle slightly and insert free end of hose into converter hub until it touches bottom.

**Note:**

Cut angle or notch end of hose before inserting, so that ATF can flow into hose.

## INSTALLING TORQUE CONVERTER

1. Make sure pump shaft is inserted fully in pump spline.

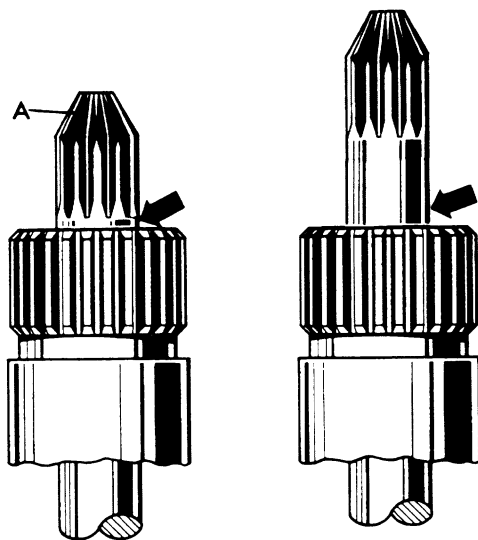

CORRECT

WRONG

2. Place converter on one-way clutch support carefully; not tilting the converter.
3. Engage converter in splines by turning back and forth slightly.

## Note :

The pump shaft has a tapered spline to make it easier to engage the drive dog in the converter and oil pump.

## REMOVING AND INSTALLING TRANSMISSION (TYPE 016 K)

## Removing

1. Remove catalytic converter together with muffler.
2. Push back dust cover on selector rod, remove locking wire on bolt and unscrew bolt.

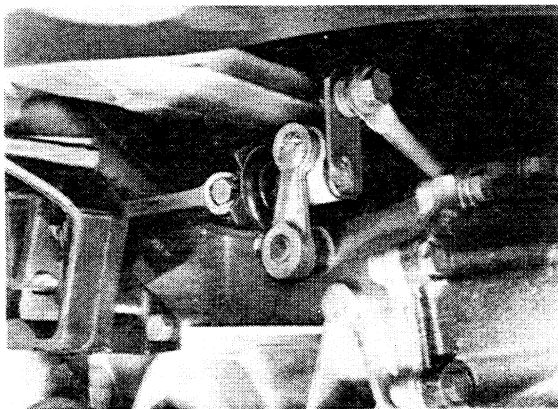

3. Remove holding clamp for shift lever knob and take off knob.

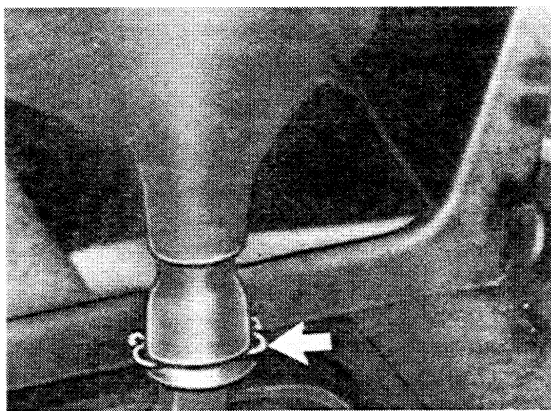

4. Remove circlip on shift lever.

5. Turn shift lever 180°. Push down on insulation sheet and push selector rod forward in tunnel cavity by about 300 mm (12 in.).

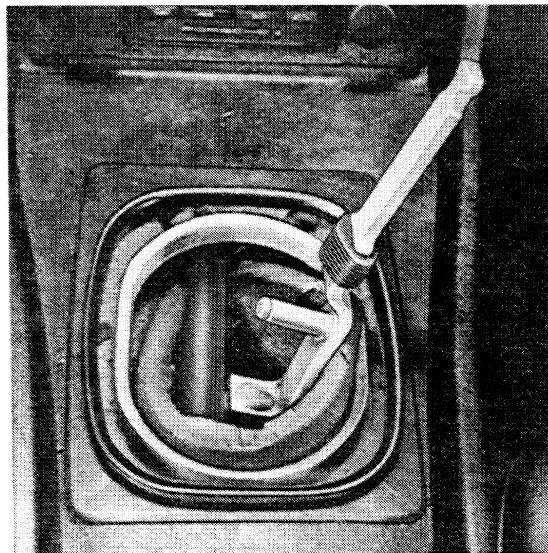

6. Remove end cap on central tube housing and push back selector rod far enough, that it is outside of the central tube housing. This requires pressing in the retainer on the protective tube with a large screwdriver applied through opening in central tube housing.

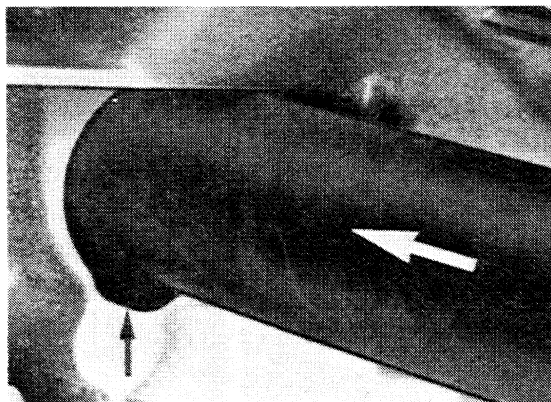

7. Unscrew clamping sleeve bolts through openings and push clamping sleeve in direction of transmission.

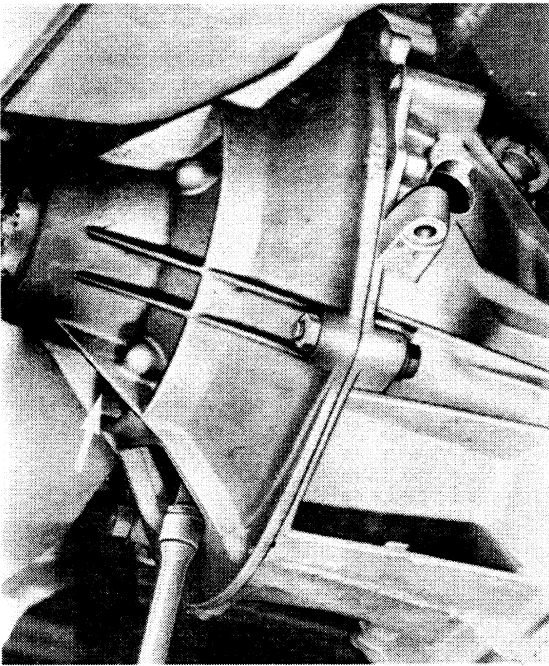

8. Detach axle shafts on transmission end and suspend from car on wire in horizontal position.

9. Pull off wires on backup light switch.

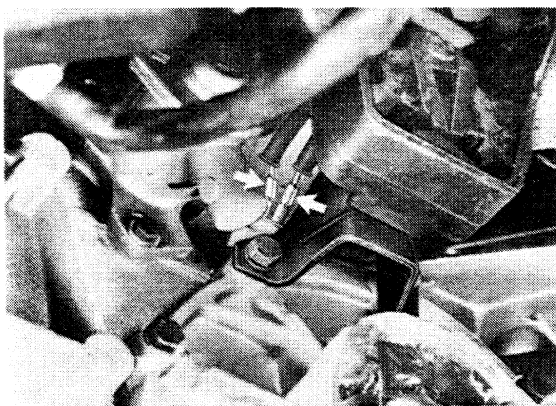

10. Place universal transmission jack underneath the transmission and secure retaining strap.

11. Remove transmission/central tube housing mounting bolts.

12. Remove bolts on transmission suspension (rubber/metal mounts).

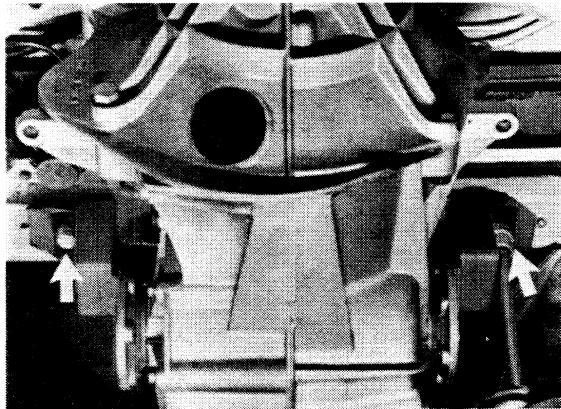

13. Lower transmission with central tube until central tube rests on rear axle cross tube. Remove transmission from below.

### Installing

1. Replace a selector rod protective tube if retainer is deformed excessively.
2. Place selector rod protective tube in transmission case. Tighten and bolt transmission. Tighten all mounting bolts to specified torque (see page 30-08).
3. Push selector rod protective tube forward until retainer engages in transmission case.

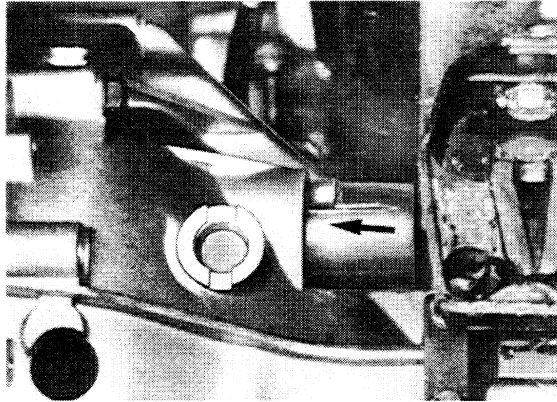

4. Mount selector rod on intermediate lever and lock with steel wire.

\_\_\_\_\_

## REMOVING AND INSTALLING TYPE 016 J AND 016 K TRANSMISSION (SINCE 1985/2 MODELS)

### Removing

1. Remove final muffler.
2. Unscrew joint shafts on transmission end and suspend from car horizontally.
3. Pull off wires for backup light switch.
4. Pull off plug on speedometer drive.
5. Push back dust cover on shift rod, remove lock wire on bolt and unscrew bolt.
6. Press leather cover for shift knob out of center console carefully and push up.

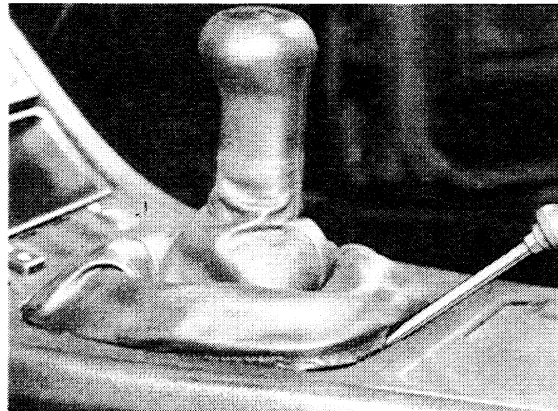
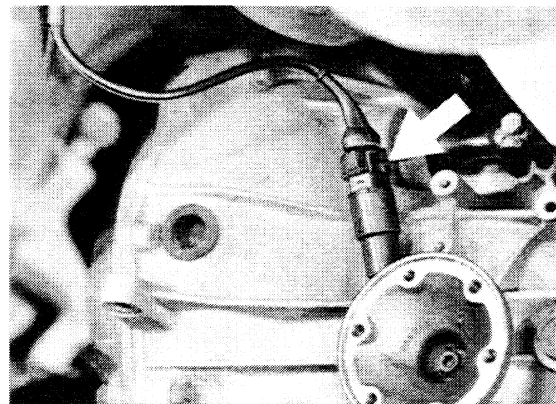
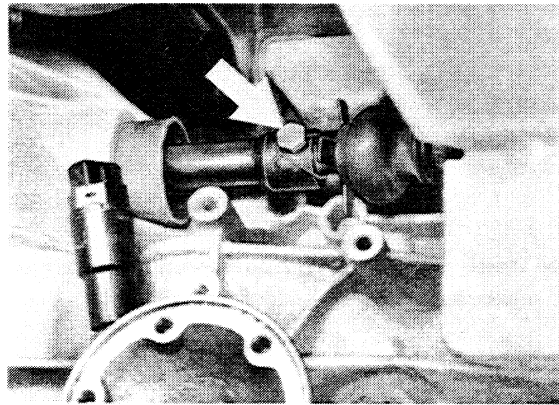
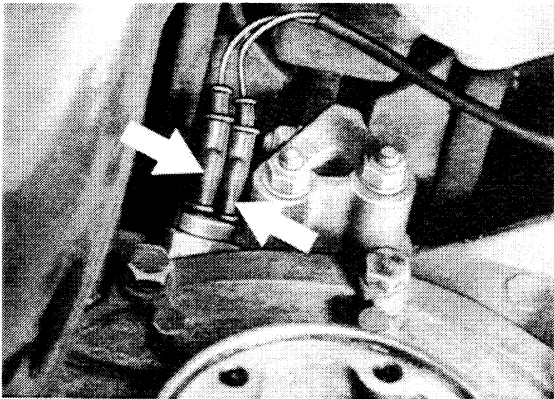



7. Remove mounting clamp for shift lever knob and take off knob.

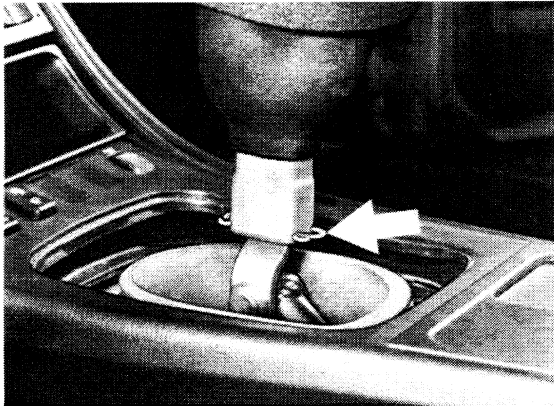

8. Remove circlip on shift lever.
9. Turn shift lever 180°. Press down on insulation sheet and push shift rod forward into produced cavity by about 300 mm.

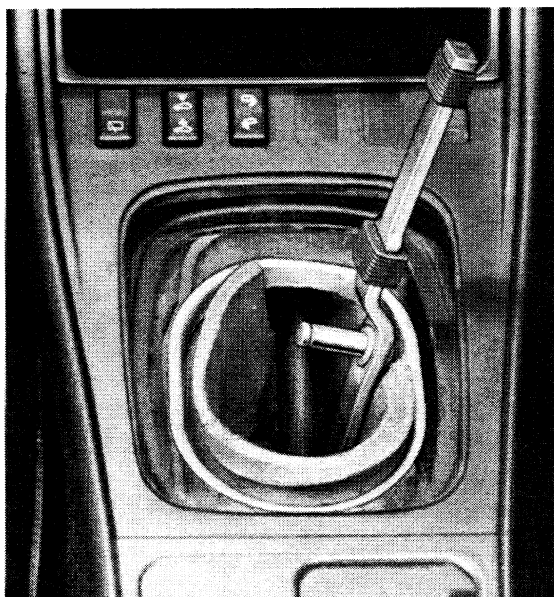

10. Unscrew clamping sleeve screws through assembly openings and push clamping sleeve toward transmission.

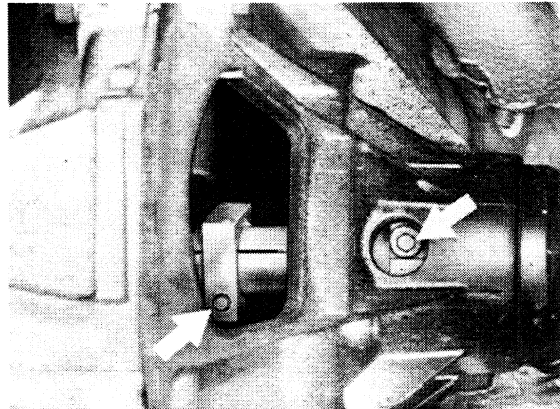

11. Push back protective tube through large opening in case far enough, that it is outside of the central pipe housing. Press in retainer with a large screwdriver for this purpose.

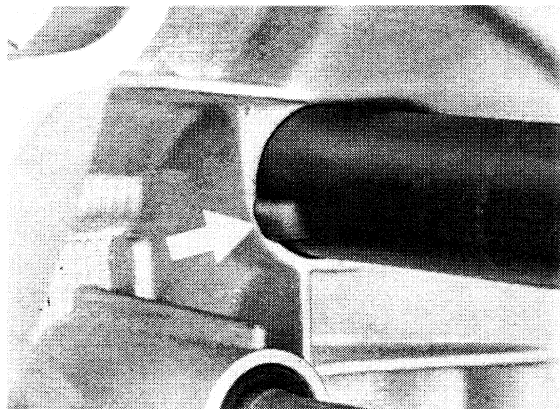

12. Hold transmission and central pipe in installed position, placing proper size wooden block between cross tube and central pipe for this purpose.
13. Place universal transmission jack underneath the transmission and attach strap.



14. Remove transmission suspension mounting bolts.

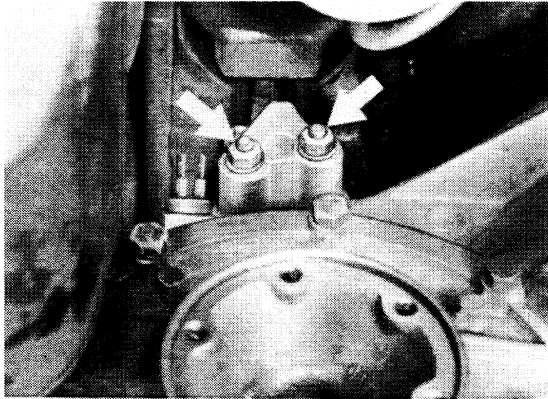

15. Remove transmission/central pipe housing mounting bolts.

16. Pull back transmission and run out downward carefully.

#### Installing

1. Install transmission with universal transmission jack.

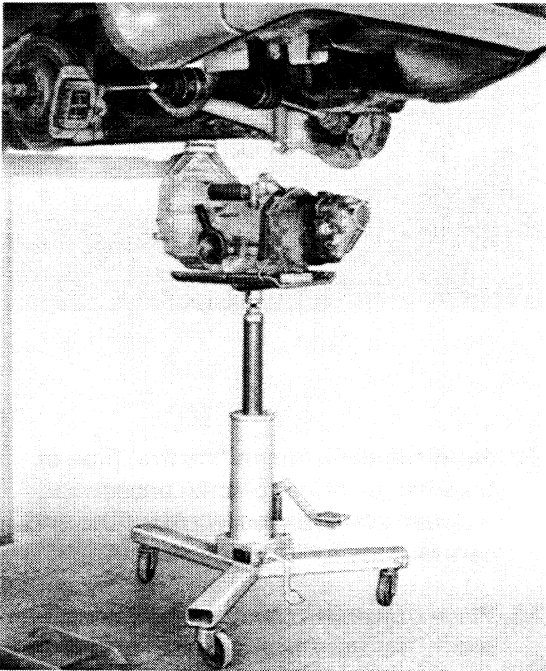

2. Replace the shift rod protective tube when retainers are deformed excessively.
3. Place shift rod protective tube in transmission case. Run in transmission and bolt. Tighten all mounting bolts to specified torque (see page 30 - 08/09).
4. Push shift rod protective tube forward until retainer engages in transmission case.

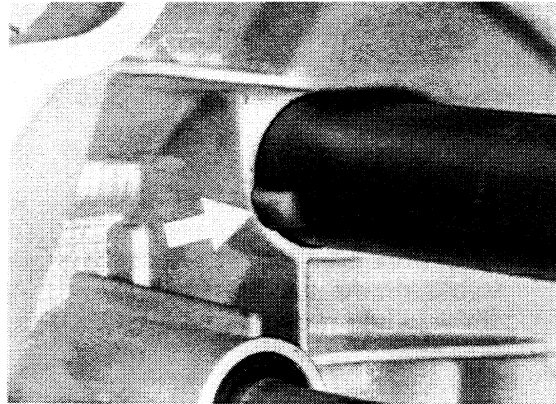

5. Mount shift rod on intermediate lever and lock clamping bolt with steel wire.

\_\_\_\_\_

## ADJUSTING SHIFT LINKAGE

1. Adjust shift lever to an inclination of  $85^{\circ}$  by moving the shift lever console. Shift lever should be in neutral for this adjustment.

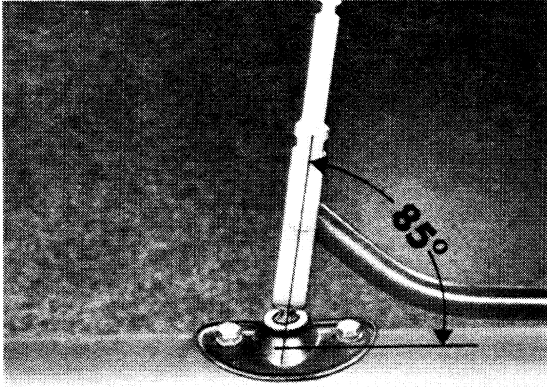

2. Shift lever in neutral. In this position a spring will hold the lateral selector shaft I in the center shift plane (3rd and 4th gear). When shift was adjusted correctly, shift lever will not have lateral inclination. Adjustments are made on intermediate shift lever for joint rod.

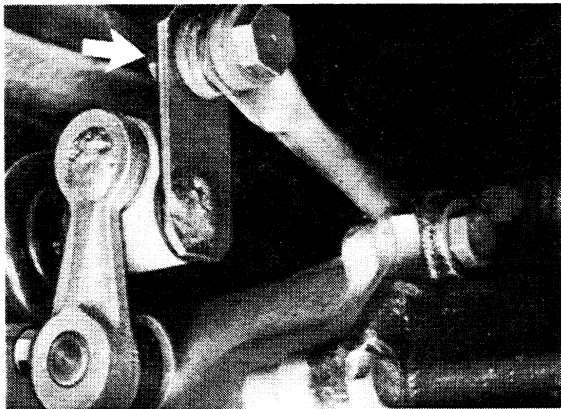

## CHECKING OIL LEVEL – REPLACING MANUAL TRANSMISSION OIL

Capacity: Approx. 2 l hypoid transmission oil SAE 75 W 90 to API Class GL or MIL-L 2105 B, or SAE 80 to API Class GL 4 or MIL-L 2105.

1. Clean outside of filler and drain plugs, and unscrew.

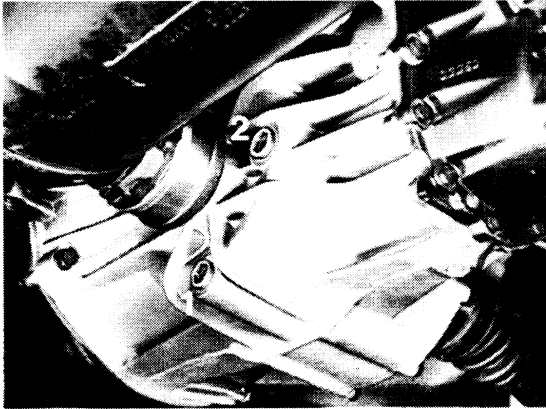

- 1 - Drain plug
- 2 - Filler plug

2. Drain transmission oil of a car parked on level ground or floor and transmission having operating temperature.
3. Clean filler and drain plugs, and torque to 24 Nm.
4. Pour in transmission oil with car parked on level surface.

**Note**

The fluid level in the transmission housings used in production is approx. 6 to 8 mm below the filler neck when 2 liters of transmission oil have been filled in.

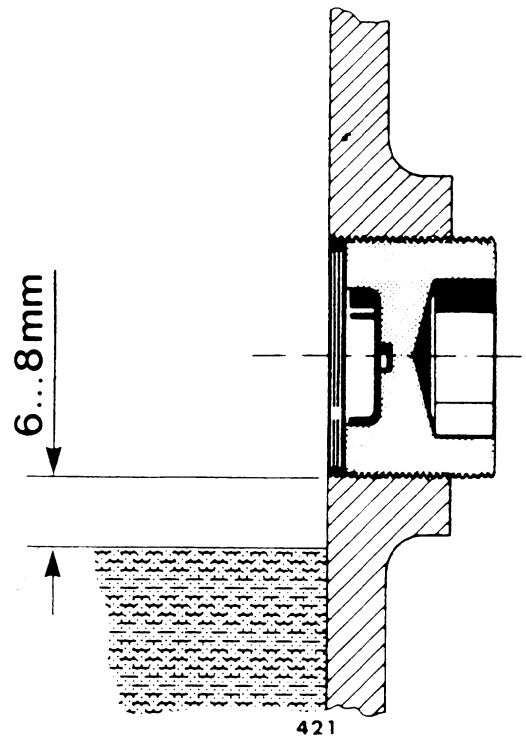

## TOOLS

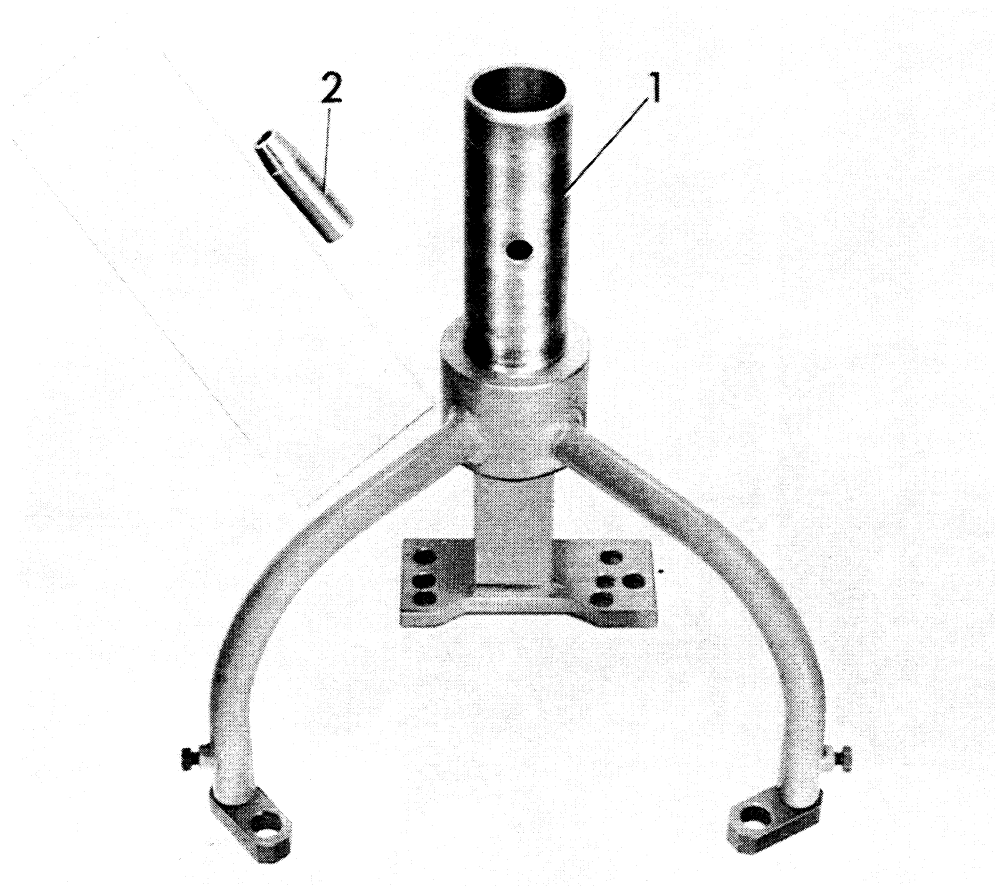

| No. | Description     | Special Tool | Remarks |
|-----|-----------------|--------------|---------|
| 1   | Assembly stand  | VW 540       |         |
| 2   | Assembly sleeve | 9178         |         |

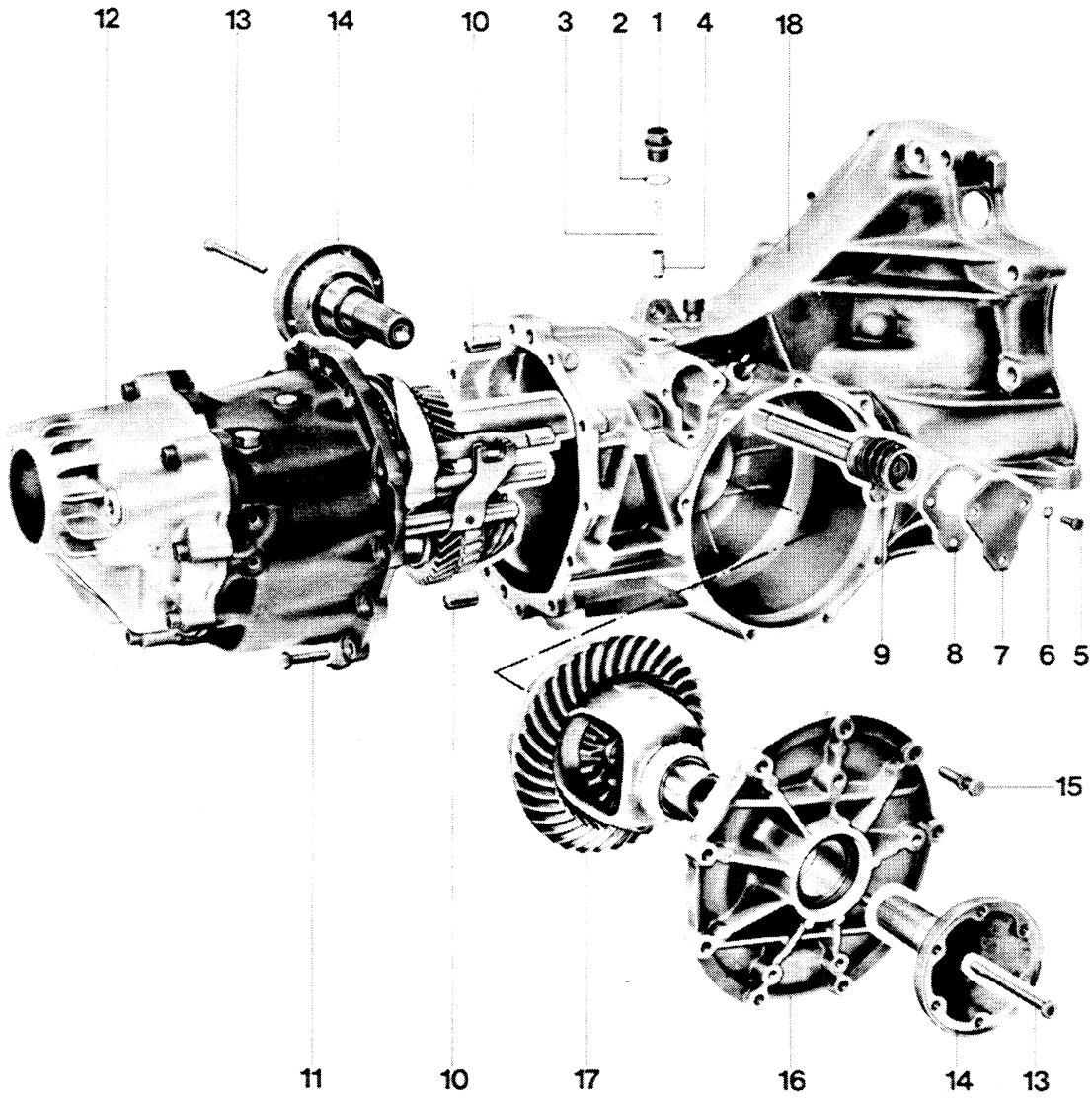

| No. | Description             | Qty. | Note When:                          |   | Special Instructions |
|-----|-------------------------|------|-------------------------------------|---|----------------------|
|     |                         |      | Removing                            | Installing  |                      |
| 1   | Threaded sleeve         | 1    |                                     | Torque: 30 Nm<br>(22 ft lb)                                 |                      |
| 2   | Gasket                  | 1    |                                     |   |                      |
| 3   | Spring                  | 1    |                                     |   |                      |
| 4   | Sleeve                  | 1    |                                     |   |                      |
| 5   | Bolt                    | 3    |                                     | Torque: 6 to 10 Nm<br>(4 to 7 ft lb)                        |                      |
| 6   | Washer                  | 3    |                                     |   |                      |
| 7   | Cover                   | 1    |                                     |   |                      |
| 8   | Gasket                  | 1    |                                     | Replace   |                      |
| 9   | Selector shaft assembly | 1    |                                     |   |                      |
| 10  | Dowel sleeve            | 2    |                                     |   |                      |
| 11  | Bolt                    | 12   |                                     | Torque: 24 Nm<br>(17 ft lb)                                 |                      |
| 12  | Gear carrier assembly   | 1    |                                     | Coat sealing surface with original VW D 3 sealing compound  |                      |
| 13  | Bolt                    | 2    |                                     | Torque: 25 Nm<br>(18 ft lb)                                 |                      |
| 14  | Flange shaft            | 2    |                                     |   |                      |
| 15  | Bolt with washer        | 9    |                                     | Torque: 25 Nm<br>(18 ft lb)                                 |                      |
| 16  | Cover                   | 1    |                                     | Position correctly – magnet faces down                      |                      |
| 17  | Differential            | 1    | Remove transmission before removing | Light oil coat for tapered roller bearings and pinion teeth |                      |

| No. | Description       | Qty. | Note When:   |            | Special Instructions |
|-----|-------------------|------|--|------------|----------------------|
|     |                   |      | Removing   | Installing |                      |
| 18  | Transmission case | 1    | If transmission case has to be replaced and deviation "r" is not on ring gear, check location of drive pinion before removing gear carrier (actual distance) |            |                      |

## REMOVING AND INSTALLING GEAR CARRIER

## R e m o v i n g

## N o t e

The differential need not be removed for jobs on the gear carrier.

If the transmission case or tapered roller bearing for the drive pinion has to be replaced and deviation "r" is not given on the ring gear, measure actual location of drive pinion before removing the gear carrier.

1. Clamp transmission in assembly stand with Special Tool VW 540 and drain oil.

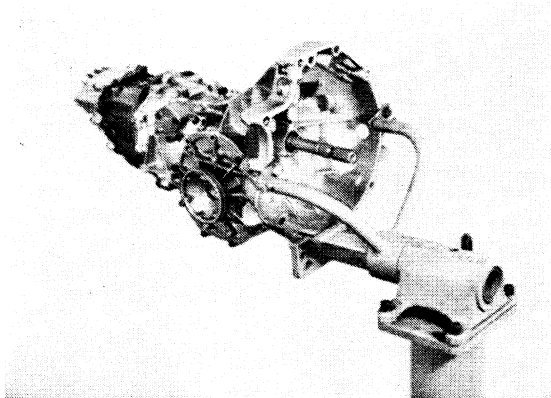

2. Remove threaded sleeve and locking parts for reverse gear lock.
3. Unscrew selector lever bolts and remove complete selector shaft (do not disassembly).
4. Drive back dowel sleeves on gear carrier.
5. Slide Special Tool 9178 on spline of input shaft.

6. Unscrew gear carrier bolts and pull out gear carrier with set of gears.

## I n s t a l l i n g

## N o t e

It is recommended to install input shaft seal after installation of gear set (danger of damaging).

1. Give gear carrier/transmission case sealing surface a thin coat of original VW D 3 sealing compound. Slide Special Tool 9178 on spline of input shaft and install gear carrier with set of gears in transmission case.
2. Drive in dowel sleeves and tighten mounting bolts to specified torque.
3. Check by shifting through all gears with Special Tool 9155.

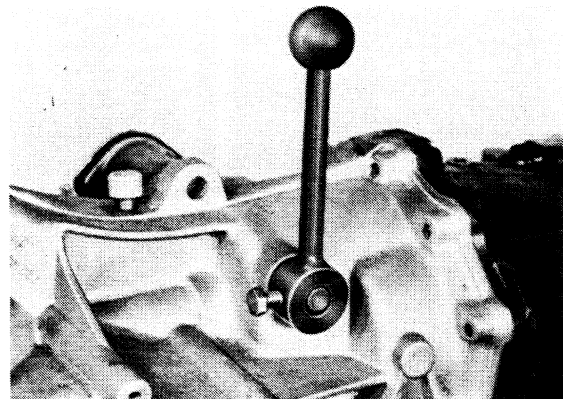



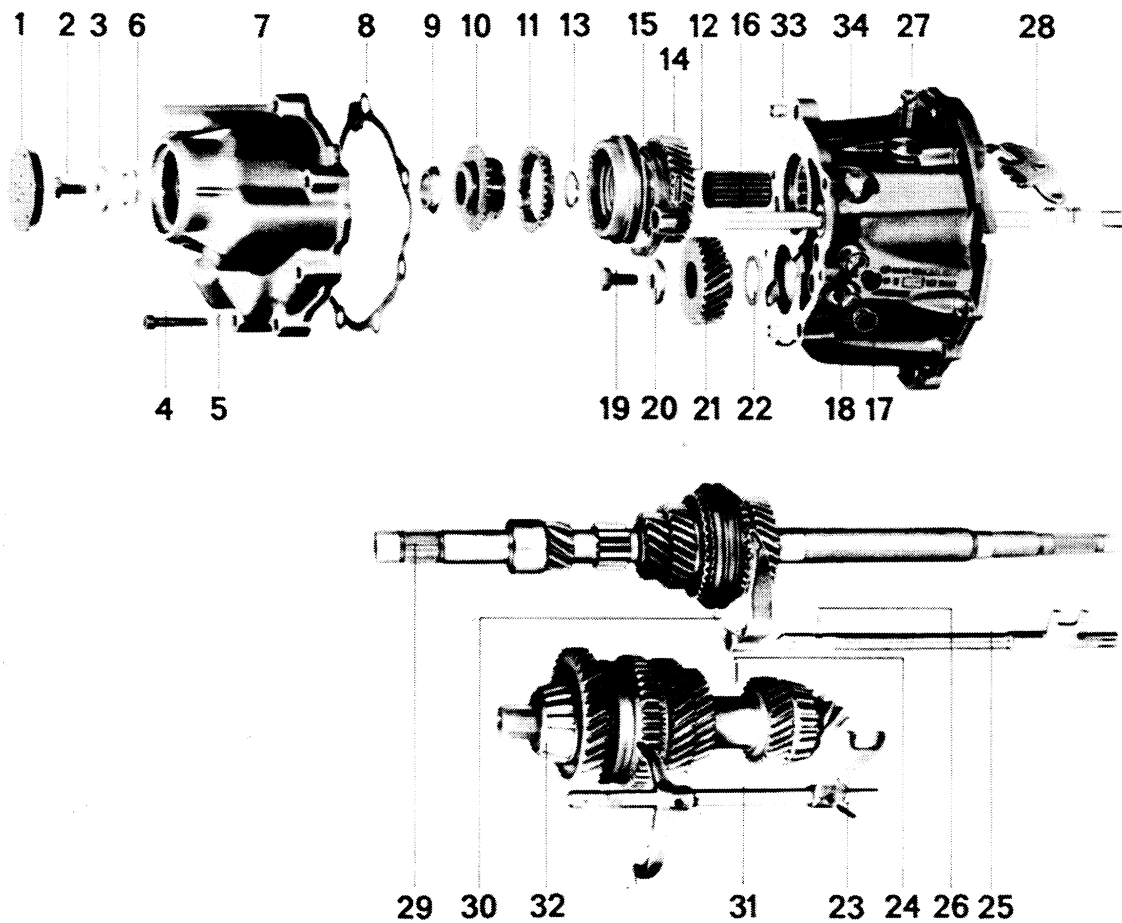

| No. | Description                                   | Qty. | Note When:   |   | Special Instructions |
|-----|---|------|--|---|----------------------|
|     |   |      | Removing   | Installing  |                      |
| 1   | End cover                                     | 1    | Insert a large screwdriver into center of rubber cover and pry out | Replace   |                      |
| 2   | Bolt 10 x 22 *                                | 1    |  | Torque: 70 Nm<br>(51 ft lb)                           |                      |
| 3   | Washer  | 1    |  |   |                      |
| 4   | Bolt 8 x 45                                   | 7    |  | Torque: 25 Nm<br>(18 ft lb)                           |                      |
| 5   | Washer  | 7    |  |   |                      |
| 6   | Ball bearing inner race                       | 1    |  |   |                      |
| 7   | Rear cover                                    | 1    | Drive off with a plastic hammer                                    |   |                      |
| 8   | Gasket  | 1    |  | Replace   |                      |
| 9   | Ball bearing inner race                       | 1    | Pull off with a two-arm puller                                     | Heat to about 120 °C (250 °F) and drive on            |                      |
| 10  | Clutch body for 5th gear                      | 1    |  |   |                      |
| 11  | Synchromesh ring                              | 1    |  | Check for wear  |                      |
| 12  | Dowel sleeve                                  | 1    |  |   |                      |
| 13  | Circlip                                       | 1    |  |   |                      |
| 14  | 5th gear with sliding sleeve and synchronizer | 1    |  | Slide on sliding sleeve with short collar facing gear |                      |
| 15  | 5th gear selector fork                        | 1    |  | Only available with selector rod for 5th gear         |                      |
| 16  | Needle bearing                                | 1    |  | Install with gear lube                                |                      |
| 17  | Stop bolt                                     | 2    |  | Torque: 30 Nm<br>(22 ft lb)                           |                      |
| 18  | Seal  | 2    |  | 0.2 mm thick, replace                                 |                      |

| No. | Description   | Qty. | Note When:                     |  | Special Instructions |
|-----|---|------|--------------------------------|--|----------------------|
|     |   |      | Removing                       | Installing   |                      |
| 19  | Bolt 10 x 22 *                                      | 1    |                                | Torque: 70 Nm<br>(51 ft lb)  |                      |
| 20  | Washer  | 1    |                                |  |                      |
| 21  | 5th gear  | 1    | Pull off with a two-arm puller | Heat to about 120 °C (250 °F) and install                            |                      |
| 22  | Adjusting screw                                     | 1    | Note thickness                 | If necessary, determine new thickness                                |                      |
| 23  | Dowel sleeve  | 1    |                                |  |                      |
| 24  | Dowel sleeve  | 1    |                                |  |                      |
| 25  | Selector rod for 3rd and 4th gear                   | 1    | Do not loose small lock pin    |  |                      |
| 26  | Small lock pin                                      | 1    |                                | Insert in selector rod with a little grease                          |                      |
| 27  | Bolt for operating lever                            | 1    |                                | Adjust operating lever and torque bolt to 35 Nm (25 ft lb)           |                      |
| 28  | Operating lever                                     | 1    |                                | Adjust before installing shafts                                      |                      |
| 29  | Input shaft   | 1    |                                | Press roller bearing inner race off of input shaft before installing |                      |
| 30  | Selector fork for 3rd and 4th gear                  | 1    |                                |  |                      |
| 31  | Selector rod and selector fork for 1st and 2nd gear | 1    |                                |  |                      |
| 32  | Drive pinion  | 1    |                                |  |                      |
| 33  | Dowel sleeve  | 2    |                                |  |                      |
| 34  | Gear carrier  | 1    |                                | Determine new shim thickness when replacing                          |                      |

\* Screws are microencapsulated. Must only be used once.

## DISASSEMBLING AND ASSEMBLING GEAR CARRIER

## Disassembling

1. Remove end cover by puncturing center of rubber with a large screwdriver and prying off cover.
2. Clamp input shaft in a vise and unscrew input shaft bolt. Fit vise with soft jaws!

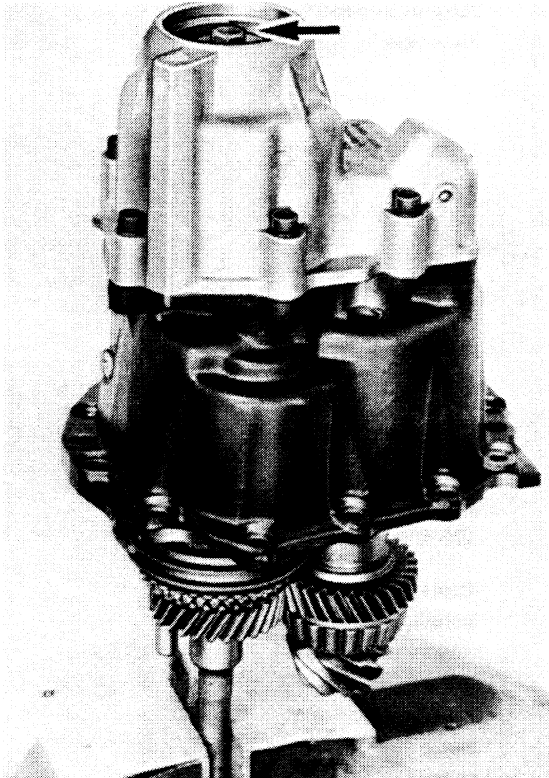
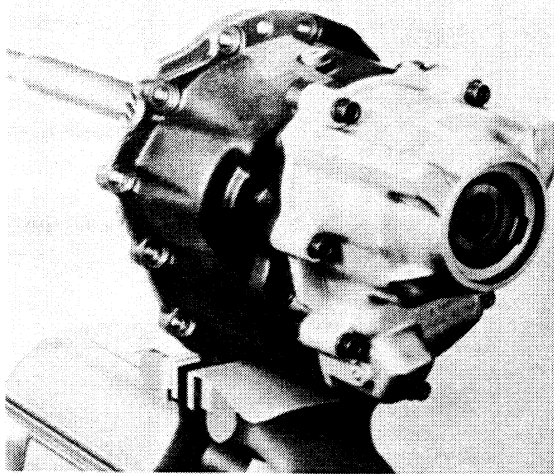

4. Drive off rear cover with a plastic hammer and remove 1st inner race/ball bearing (A).

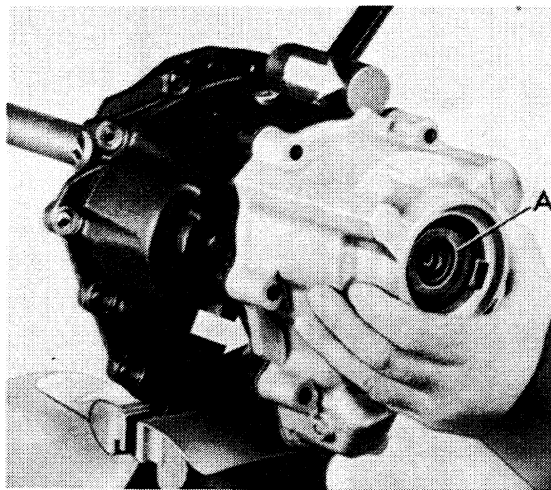

3. Clamp gear carrier in vise and unscrew rear cover mounting bolts.

5. Pull off clutch body and 2nd inner race/ball bearing.

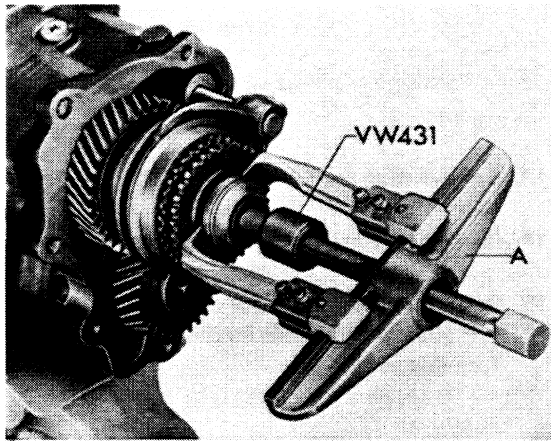

- A – Two-arm puller (standard),  
e. g. Kukko 20/10

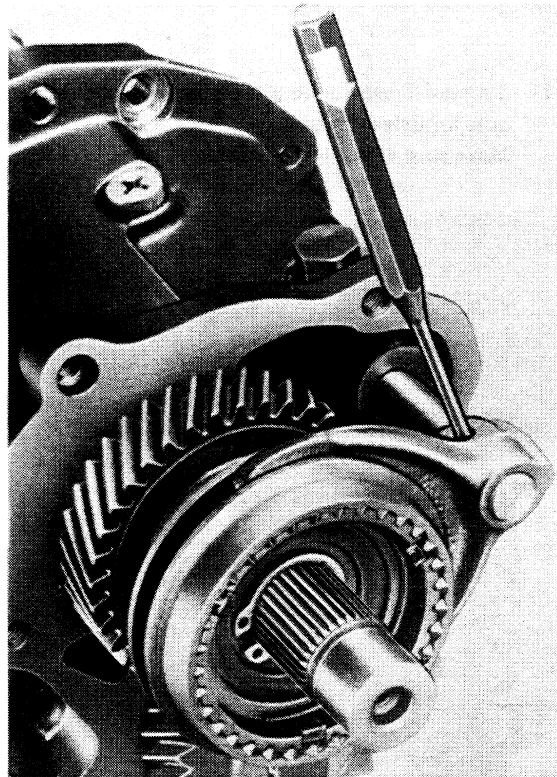

6. Remove 5th gear synchromesh ring.

8. Remove circlip for synchronizer.

7. Drive out 5th gear selector fork dowel sleeve.  
Hold with a hammer so that selector rod bore in  
end bracket is not widened.

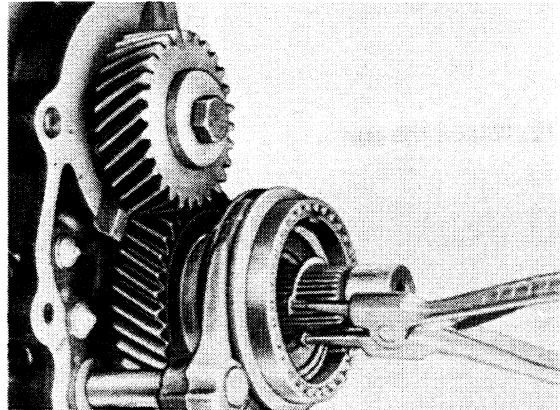

9. Remove 5th gear with sliding sleeve and  
synchronizer, needle bearing and 5th gear  
selector fork.  
Selector rod remains in gear carrier!

10. Unscrew stop bolts for selector rods.
11. Clamp 4th gear/drive pinion in a vise and unscrew bolt for drive pinion.  
Make sure vise is fitted with soft jaws!

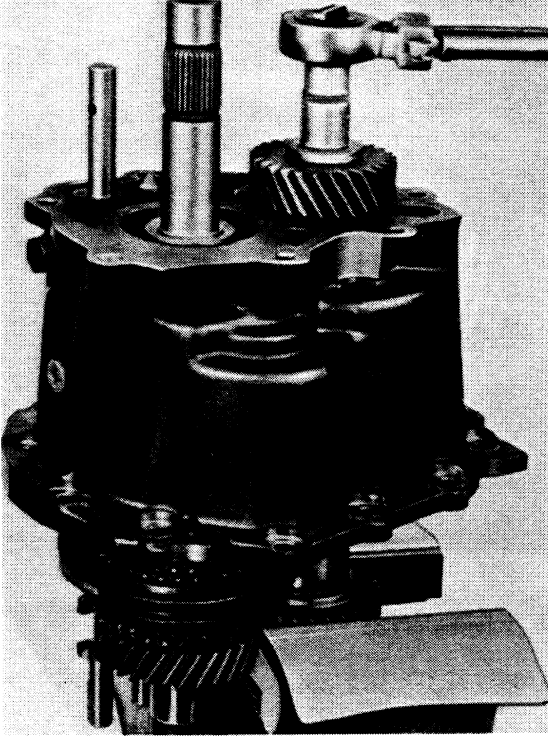

- A – Two-arm puller (standard)  
e. g. Kukko 20/10, if necessary grind off claws slightly or pry away gear slightly with two tire irons.

13. Remove shim for 5th gear.
14. Clamp gear carrier with shafts forward in vise.
15. Drive out dowel sleeve for dog on 1st and 2nd gear selector rod, while holding with a hammer. Turn dog to face up.

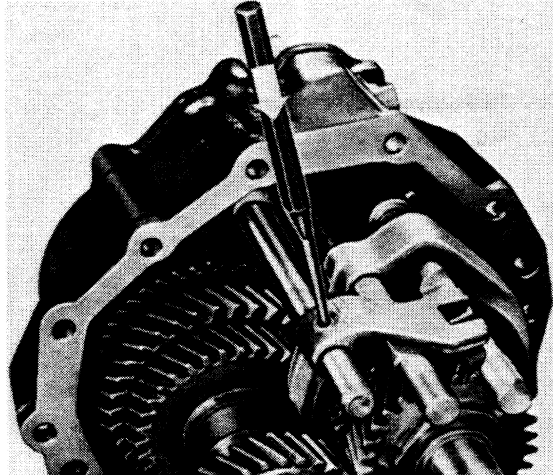

12. Pull off 5th gear.

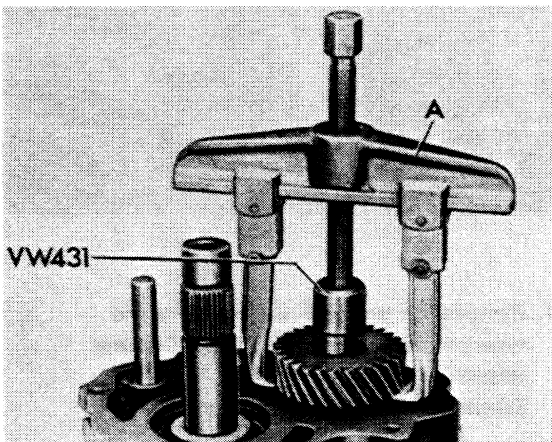

16. Drive out dowel sleeve for 3rd and 4th gear selector fork, while holding with a hammer.

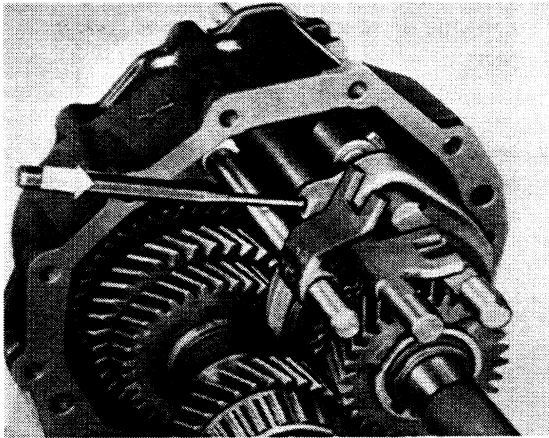

17. Pull out selector rod for 3rd and 4th gears (selector fork remains in sliding sleeve). Do not loose small lock pin!

18. Unscrew bolt for operating lever.

19. Pull drive pinion and input shaft forward slightly. Remove input shaft with 3rd and 4th gear selector fork.

**Note:** For transmissions with reverse gear synchronization disconnect spring clamp for reverse gear on pinion shaft end and turn aside.

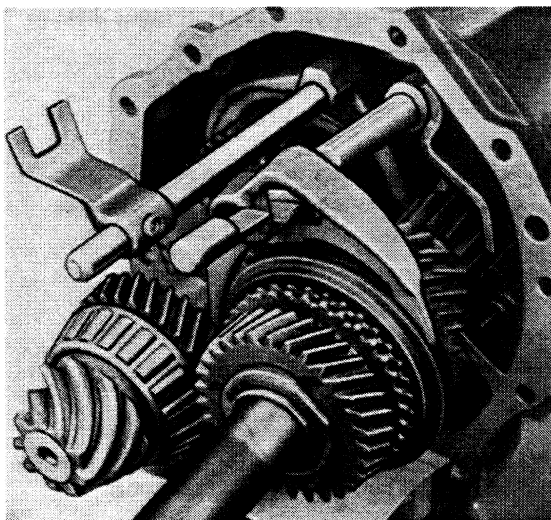

20. Pull drive pinion forward far enough so that selector rod and selector fork for 1st and 2nd gears can be removed.

21. Swing out drive pinion.

### Assembling

1. Position lock pin in bore correctly.

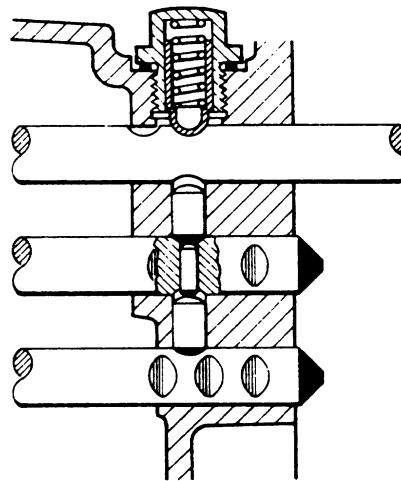

2. Insert springs and sleeves for gear interlock (1st through 4th gears).

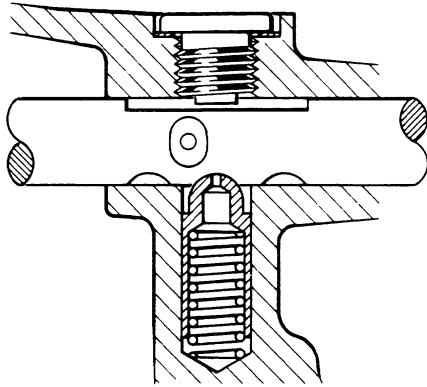

3. Adjust operating lever (see page 34 - 35).
4. Swing in drive pinion, engaging reverse gear for this purpose.

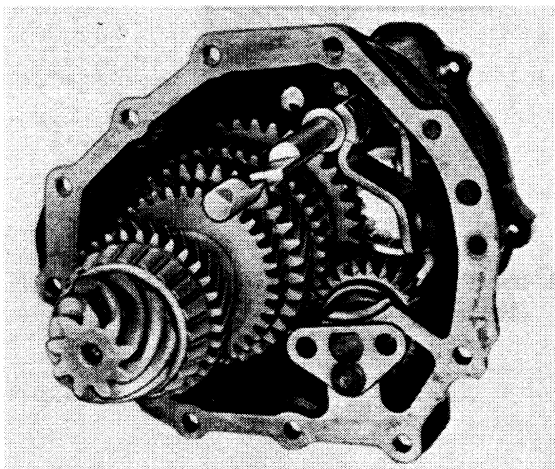

5. Insert selector fork and selector rod for 1st and 2nd gears, and push in drive pinion fully.

6. Slide in 3rd and 4th gear selector fork positioned correctly on selector rod for 5th and reverse gears.

7. Install input shaft, insert 3rd and 4th gear selector fork in sliding sleeve and push in input shaft completely.

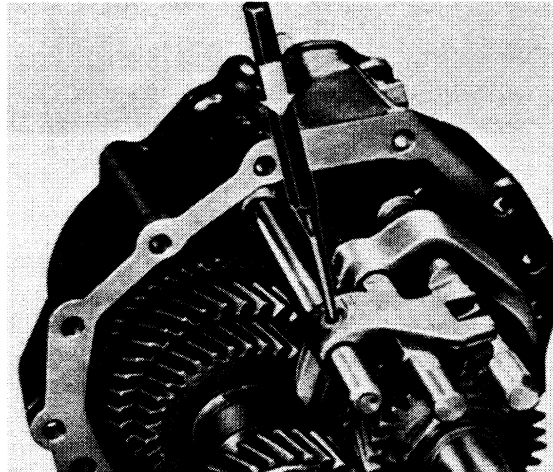

#### Note

Press roller bearing inner race off of input shaft to make installation easier.

8. Adjust selector rods to neutral position and make sure locks are positioned correctly (see page 34 - 36).
9. Slide in 3rd and 4th gear selector rod with small lock (held in position with grease).
10. Lock 3rd and 4th gear selector fork on selector rod with a pin, holding with a hammer.



11. Lock dog for 1st and 2nd gear selector rod on selector rod with a pin, while holding with a hammer.

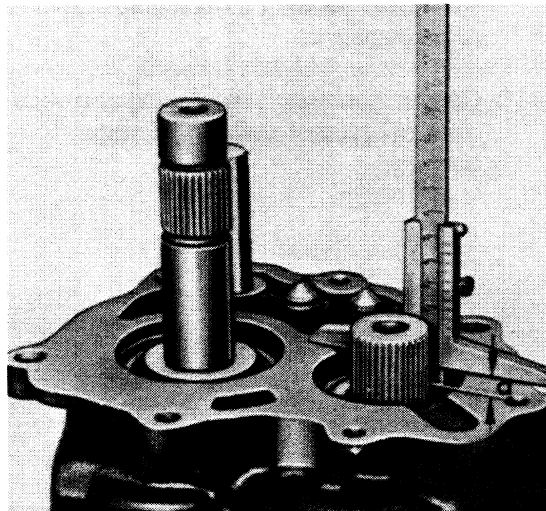
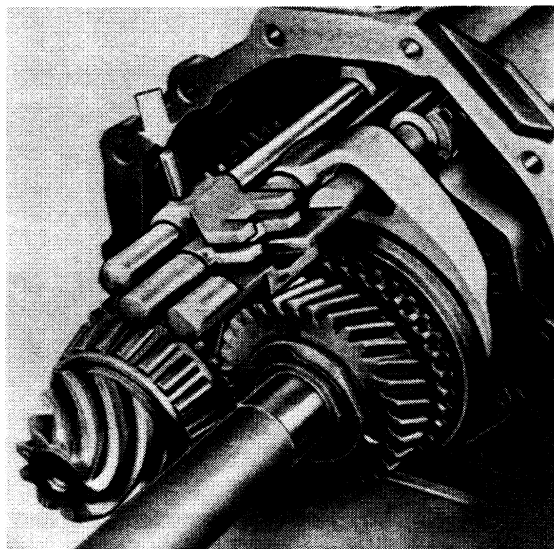

12. Install stop bolts with new seals and tighten to specified torque.
13. Clamp 4th gear/drive pinion in a vise.
14. Determine thickness of shim for 5th gear.

Measure distance "a" with a depth gauge and refer to following table for thickness and part number of shim.

| Distance "a"<br>(mm) | Shim           |               |
|----------------------|----------------|---------------|
|                      | Thickness (mm) | Part Number   |
| 8.35 . . . 8.64      | 1.1            | 016 311 391   |
| 8.65 . . . 8.94      | 1.4            | 016 311 391 A |
| 8.95 . . . 9.24      | 1.7            | 016 311 391 B |
| 9.25 . . . 9.54      | 2.0            | 016 311 391 C |
| 9.55 . . . 9.84      | 2.3            | 016 311 391 D |

15. Heat 5th gear/drive pinion to about 120 °C and install gear with collar facing drive pinion. If necessary, knock on against stop with a suitable mandrel.

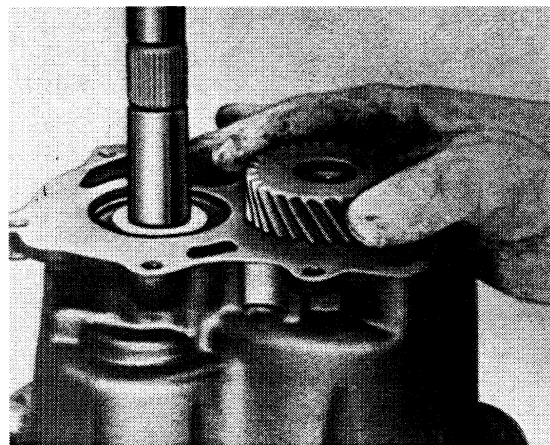

16. Tighten bolt for drive pinion to specified torque.

17. Clamp input shaft in a vise that shafts are vertical.
18. Lubricate cylindrical rollers of input shaft bearing with a little grease and press outward.
19. Center input shaft in bearing and slide on inner race of cylindrical roller bearing.

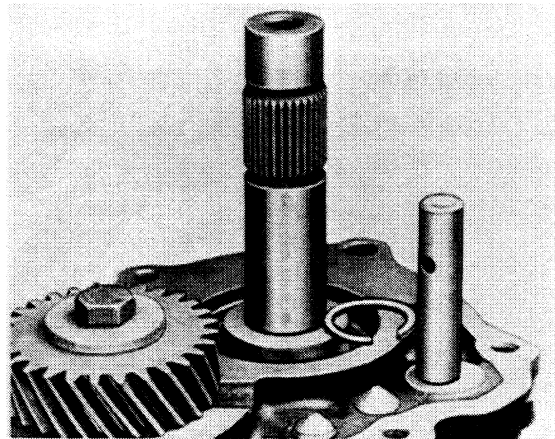
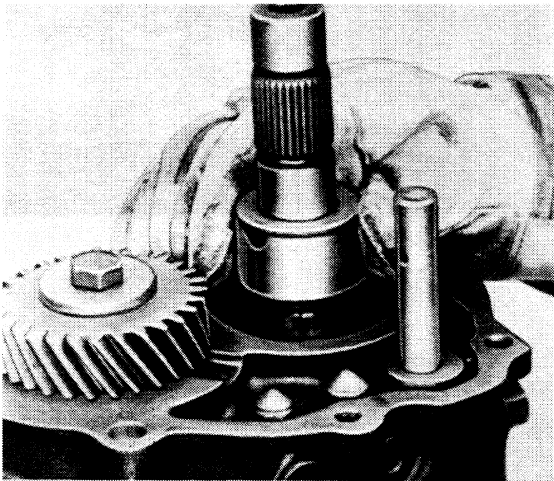

21. Mount 5th gear with synchronizer and sliding sleeve, needle bearing and selector fork. Lock selector fork on selector rod with a pin, holding with a hammer.

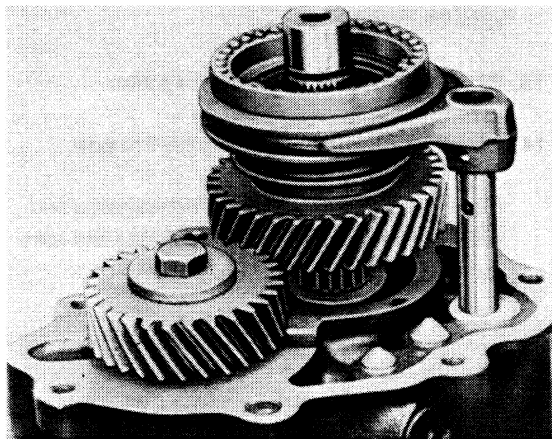

20. Determine thickness of circlip for cylindrical roller bearing inner race. Use and install the thickest possible circlip. Axial play may be max. 0.05 mm.

The following circlips are available.

| Part Number  | Thickness (mm) |
|--------------|----------------|
| N 900.606.01 | 1.35           |
| N 900.606.02 | 1.40           |
| N 900.606.03 | 1.45           |

22. Insert circlip for synchronizer.
23. Insert 5th gear synchromesh ring.

24. Heat clutch to about 120 °C (250 °F) and mount, driving it on against stop with a suitable piece of pipe if necessary.

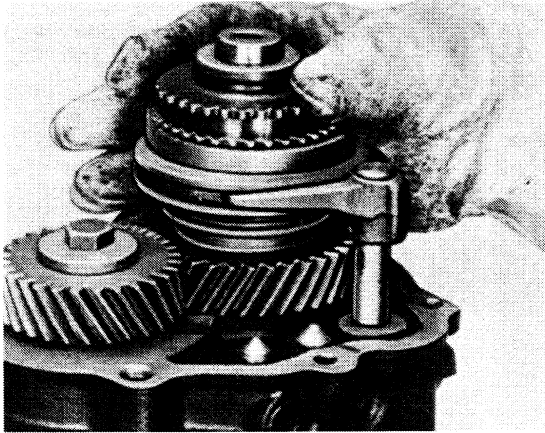

25. Heat 2nd ball bearing inner race to about 120 °C (250 °F) and install.
26. Install dowel sleeves, position gasket and mount rear cover.
27. Heat 1st ball bearing inner race to about 120 °C (250 °F) and install.
28. Tighten bolt for input shaft to specified torque.
29. Tighten cover/gear carrier bolts to specified torque.
30. Press in new end cover.

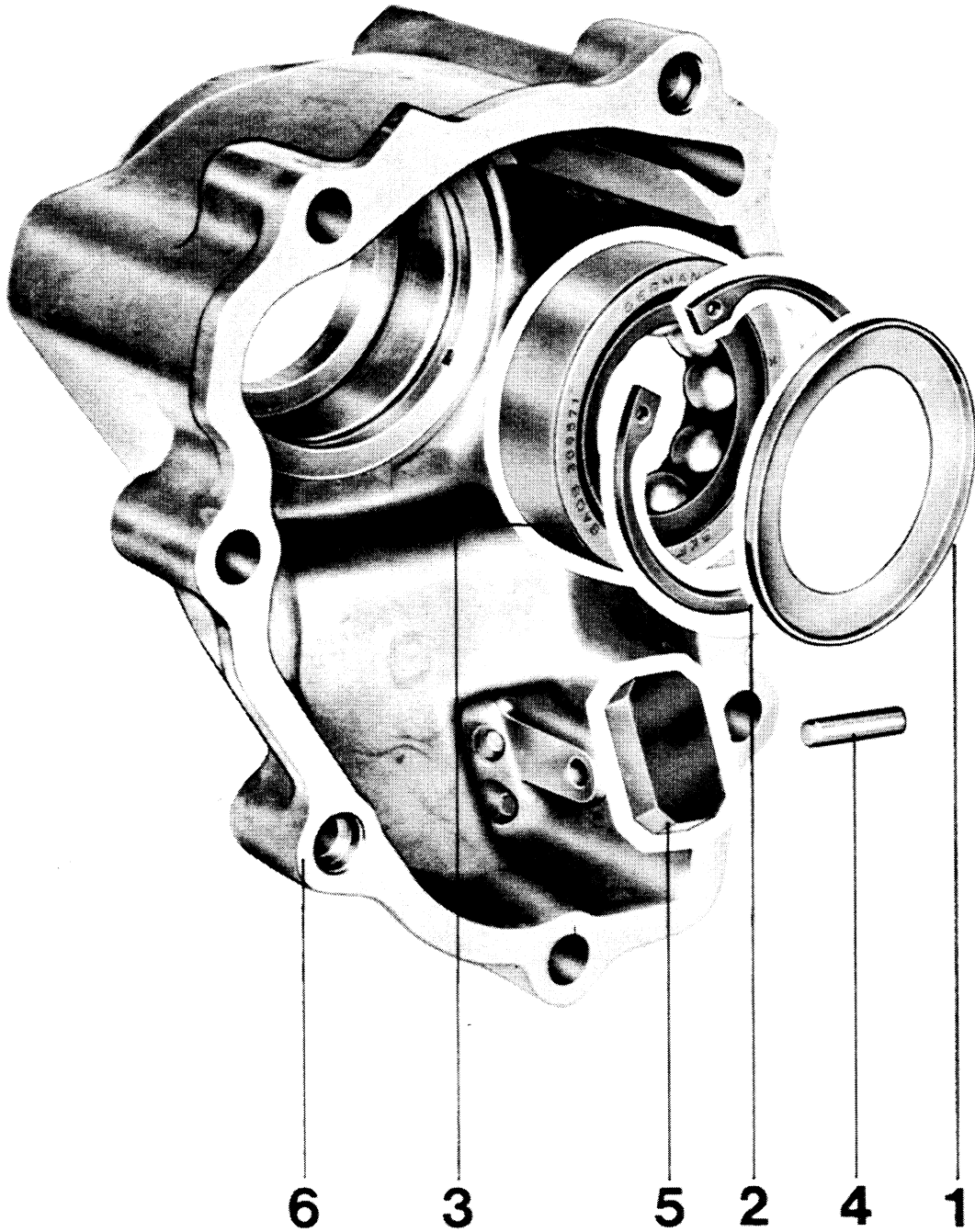

| No. | Description     | Qty. | Removing                          | Note When:<br>Installing   | Special<br>Instructions |
|-----|-----------------|------|-----------------------------------|----------------------------|-------------------------|
| 1   | Baffle plate    | 1    | Drive out with a suitable mandrel | Punch lock at three points |                         |
| 2   | Circlip         | 1    |                                   |                            |                         |
| 3   | Ball bearing    | 1    | Press out with inner race         | Press in with 30-205       |                         |
| 4   | Cylindrical pin | 1    |                                   |                            |                         |
| 5   | Magnet          | 1    |                                   |                            |                         |
| 6   | Cover           | 1    |                                   |                            |                         |

#### DISASSEMBLING AND ASSEMBLING REAR COVER

##### Disassembling

1. Drive out baffle plate with a suitable mandrel and remove circlip.
2. Press out ball bearing, inserting inner race of ball bearing for this purpose.

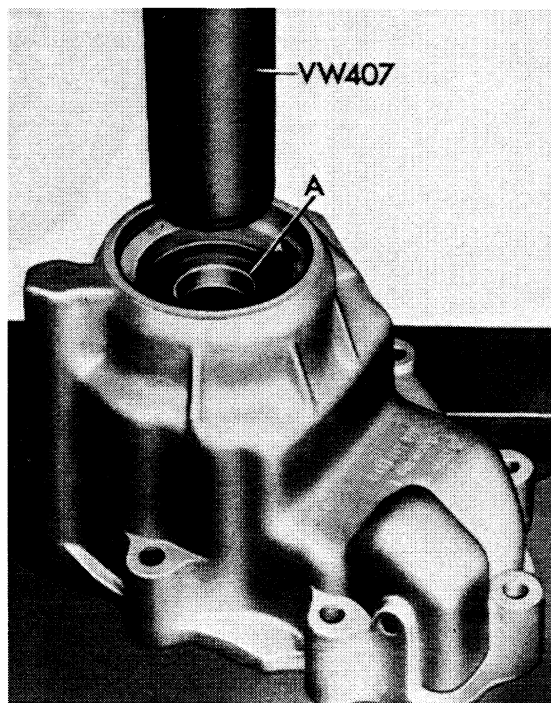

A – Inner race of ball bearing

## Assembling

1. Press in ball bearing against stop with a suitable pressing tool (e. g. 30-205).

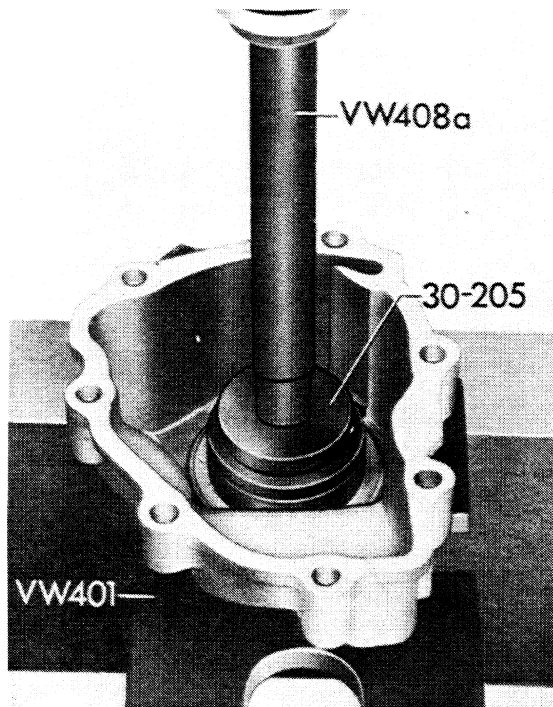

2. Insert circlip in groove. Press in baffle plate and punch at three points to lock.

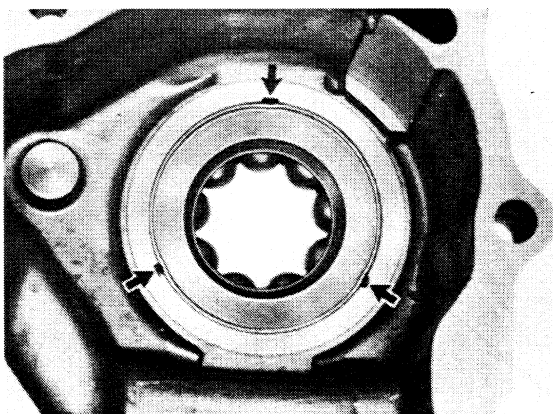

## TOOLS

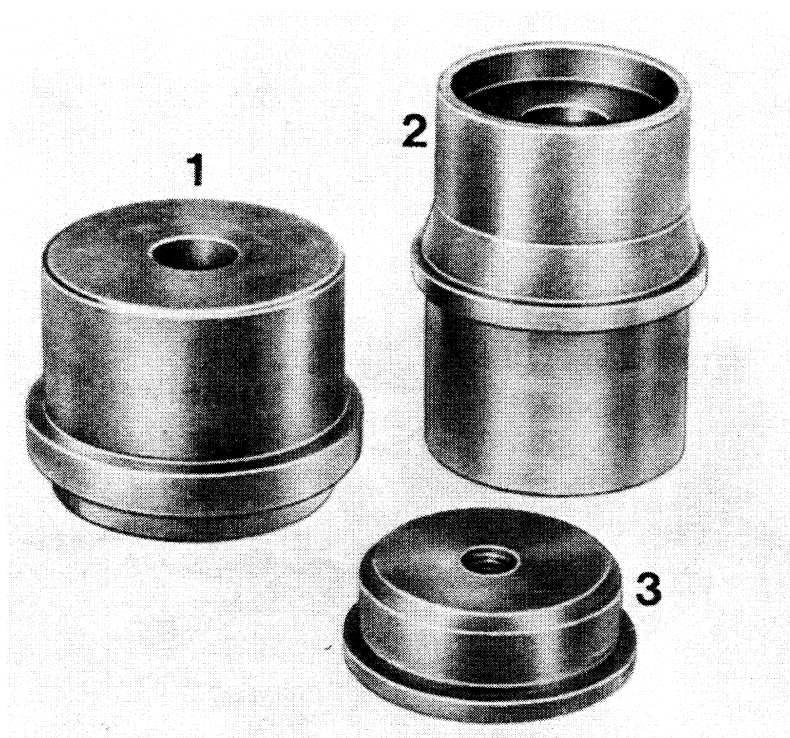

| No. | Description   | Special Tool | Remarks |
|-----|---------------|--------------|---------|
| 1   | Pressing tool | VW 472       |         |
| 2   | Pressing tool | VW 473       |         |
| 3   | Pressing tool | P 254 b      |         |

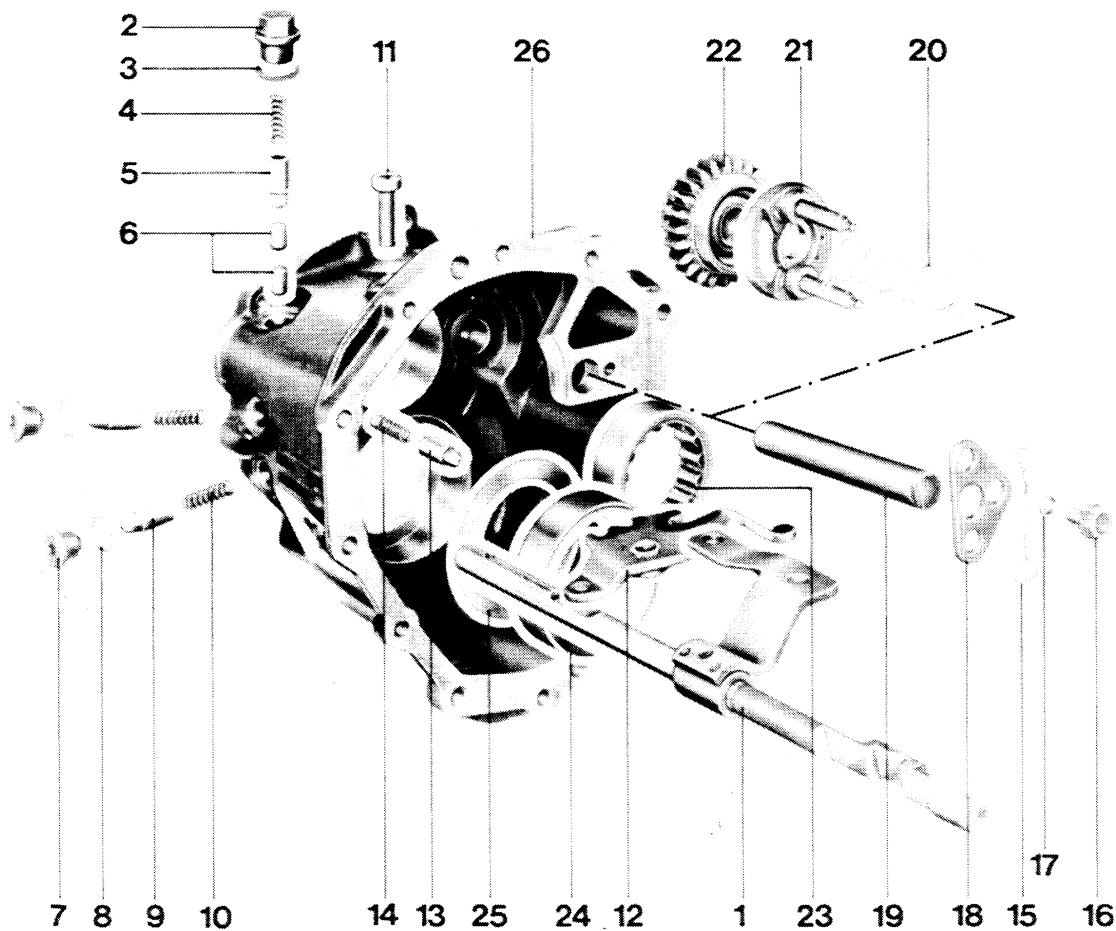



| No. | Description                         | Qty. | Note When: |  | Special Instructions                             |
|-----|-------------------------------------|------|------------|--|--|
|     |                                     |      | Removing   | Installing   |  |
| 1   | Shift rod for 5th and reverse gears | 1    |            | Only available as complete spare part  |  |
| 2   | Threaded sleeve                     | 1    |            | Torque: 30 Nm  |  |
| 3   | Seal                                | 1    |            | Replace  |  |
| 4   | Spring                              | 1    |            |  |  |
| 5   | Bushing                             | 1    |            |  |  |
| 6   | Lock                                | 2    |            |  |  |
| 7   | Stop screw                          | 2    |            | Torque: 30 Nm  |  |
| 8   | Seal                                | 2    |            |  |  |
| 9   | Bushing                             | 2    |            |  |  |
| 10  | Spring                              | 2    |            |  |  |
| 11  | Bolt                                | 1    |            | Adjust operating lever and torque bolt to 35 Nm  |  |
| 12  | Operating lever                     | 1    |            | Adjust   |  |
| 13  | Bushing                             | 1    |            |  |  |
| 14  | Spring                              | 1    |            |  |  |
| 15  | Spring clamp                        | 1    |            |  |  |
| 16  | Bolt                                | 1    |            | Torque: 24 Nm  | Since Aug. 1984 bolt with collar, spacer omitted |
| 17  | Spacer                              | 1    |            |  |  |
| 18  | Holder                              | 1    |            |  |  |
| 19  | Reverse gear shaft                  | 1    |            |  |  |
| 20  | Spring                              | 1    |            | Connect single angled end in recess of synchro-mesh ring. Turn double angled end to left and connect in end bracket through opening. |  |

| No. | Description                         | Qty. | Note When:                                    |  | Special Instructions |
|-----|-------------------------------------|------|---|--|----------------------|
|     |                                     |      | Removing                                      | Installing   |                      |
| 21* | Synchromesh ring                    | 1    |   | Check for wear   |                      |
| 22  | Reverse gear                        | 1    |   |  |                      |
| 23  | Cylinder roller bearing, outer race | 1    | Press out with 254 b                          | Press in to correct position with 254 b                      |                      |
| 24  | Tapered roller bearing, outer race  | 1    | Press out suitable pipe section (e.g. VW 473) | Press in with VW 472   |                      |
| 25  | Shim S <sub>4</sub>                 | X    | Note thickness for re-installing              | Determine new thickness if necessary                         |                      |
| 26  | End plate                           | 1    |   | If replaced, determine new thickness for shim S <sub>4</sub> |                      |

\*Install in correct position. Flattened side must face gear set.

INSTRUCTIONS FOR DISASSEMBLY AND ASSEMBLY

Disassembly

1. Press out cylindrical roller bearing outer race with P 254b.

2. Press out tapered roller bearing outer race with suitable pipe section (e.g. VW 473).

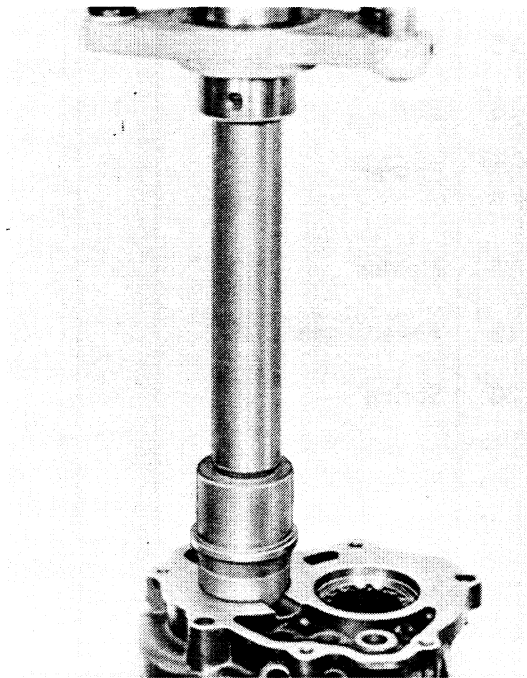
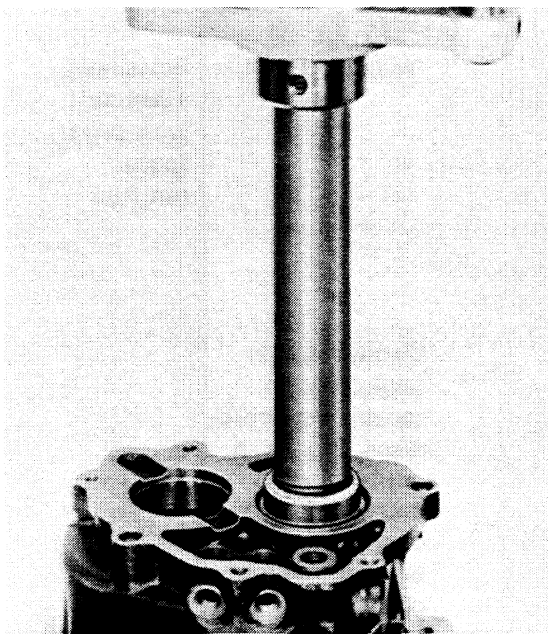

**Assembling**

1. Press in cylindrical roller bearing outer race to correct position with P 254 b.

Pressed depth a = 8.5 to 9.0 mm.

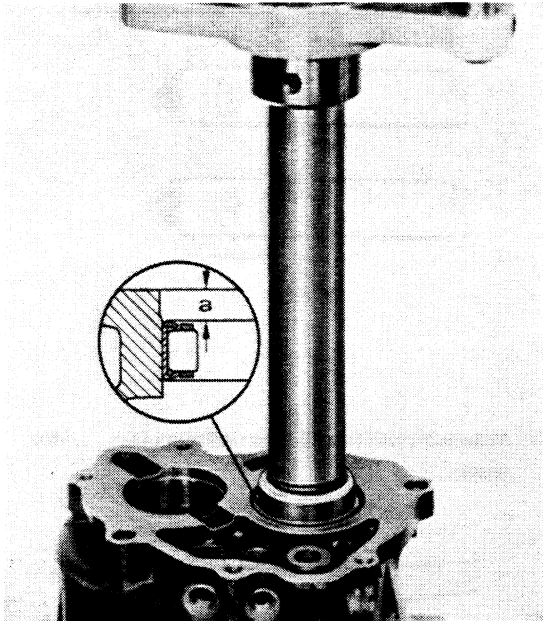

2. Press in tapered roller bearing outer race with VW 472.

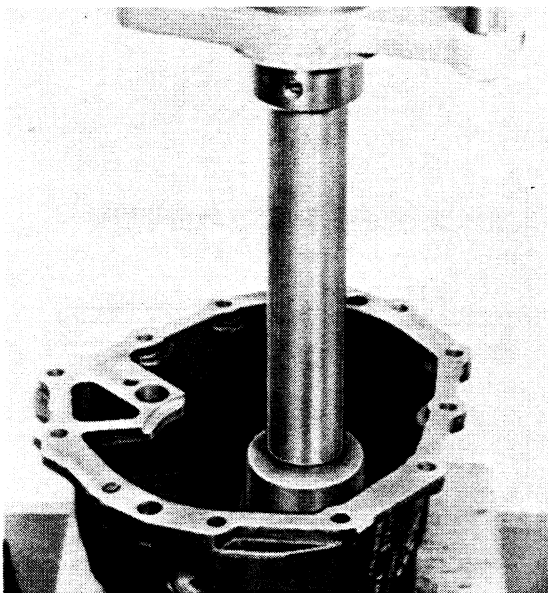

3. Check synchronesh ring.  
Press synchronesh ring on cone of gear and measure clearance "a" with a feeler gauge blade.

| Clearance "a" | New Installed Distance | Wear Limit |
|---------------|------------------------|------------|
| Reverse gear  | 0.75 – 2.3 mm          | 0.2 mm     |

4. Adjust operating lever.  
Insert reverse gear lock.  
Insert selector rod for 5th and reverse gears as well as operating lever in correct position.  
Press operating lever in direction of arrow until it rests on selector rod and dog of gear.

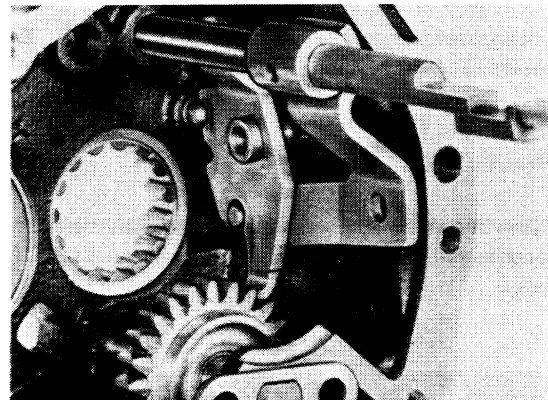

Screw in adjusting screw against stop on threaded sleeve.

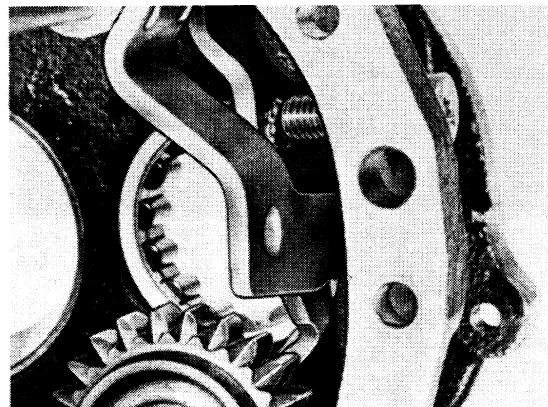

Press operating lever against bolt and loosen bolt until beginning of threads is heard to mesh in threaded sleeve (loosen at least 1/4 turn).

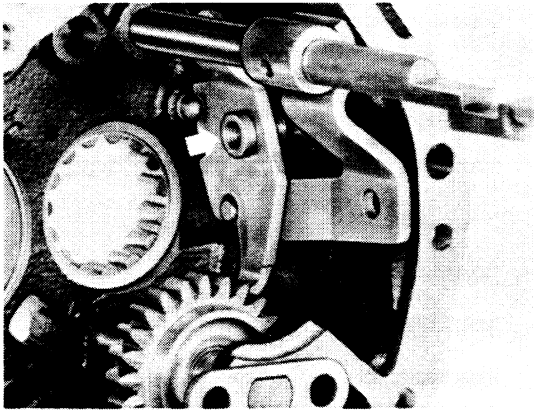

Screw in bolt and tighten to specified torque.

Engage reverse gear several times and check that all points of reversing mechanism move easily.

**Note :**

Operating lever has been adjusted correctly when it is centered exactly above bushing for reverse gear lock.

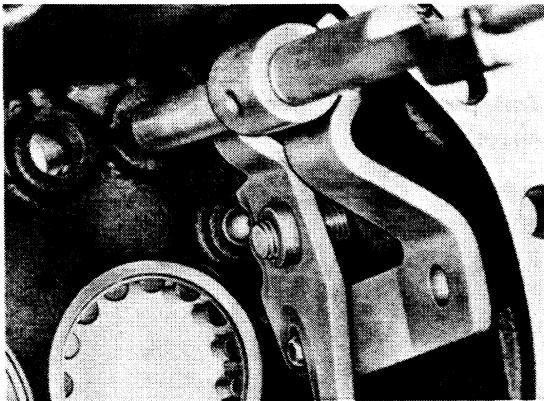

5. Installed position of locks and 5th gear detent.

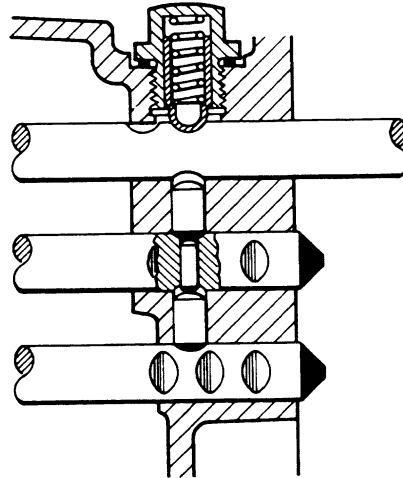

6. Installed position of gear detents (1st . . . 4th gears).

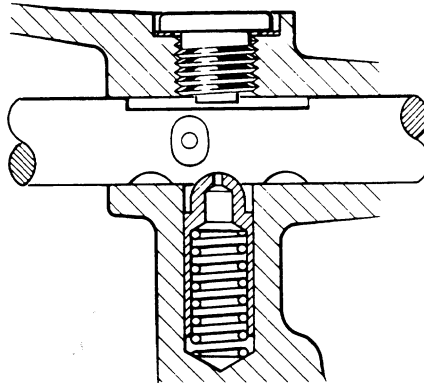

7. Installed position of reverse gear detent.

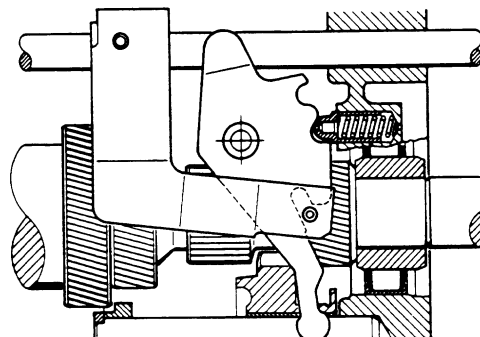

### Determining Thickness of Shim "S<sub>4</sub>"

Shims available as spare parts:

This procedure will be necessary after replacing the gear carrier housing. It provides preload for the drive pinion's tapered roller bearings.

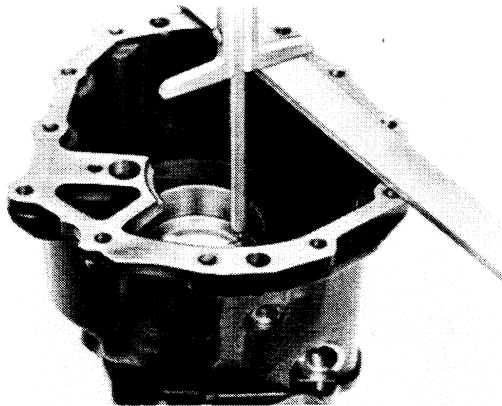

| Thickness (mm) |
|----------------|
| 0.24           |
| 0.27           |
| 0.30           |
| 0.33           |
| 0.36           |
| 0.39           |
| 0.42           |
| 0.45           |
| 0.69           |
| 0.93           |
| 1.17           |
| 1.41           |

Measure case depth "a" of old and new gear carrier housing and determine difference.

Example:

|                                       |   |                  |
|---------------------------------------|---|------------------|
| Old gear carrier housing<br>depth "a" | = | 119.10 mm        |
| New gear carrier housing<br>depth "a" | = | <u>119.35 mm</u> |
| Difference                            |   | 0.25 mm          |

New gear carrier housing is deeper =  
install thicker shim S<sub>4</sub>.

Old gear carrier housing is deeper =  
install thinner shim S<sub>4</sub>.

Example:

|                         |   |                |
|-------------------------|---|----------------|
| Old shim                | = | 0.95 mm        |
| + difference            | = | <u>0.25 mm</u> |
| New shim S <sub>4</sub> | = | 1.20 mm        |

## TOOLS

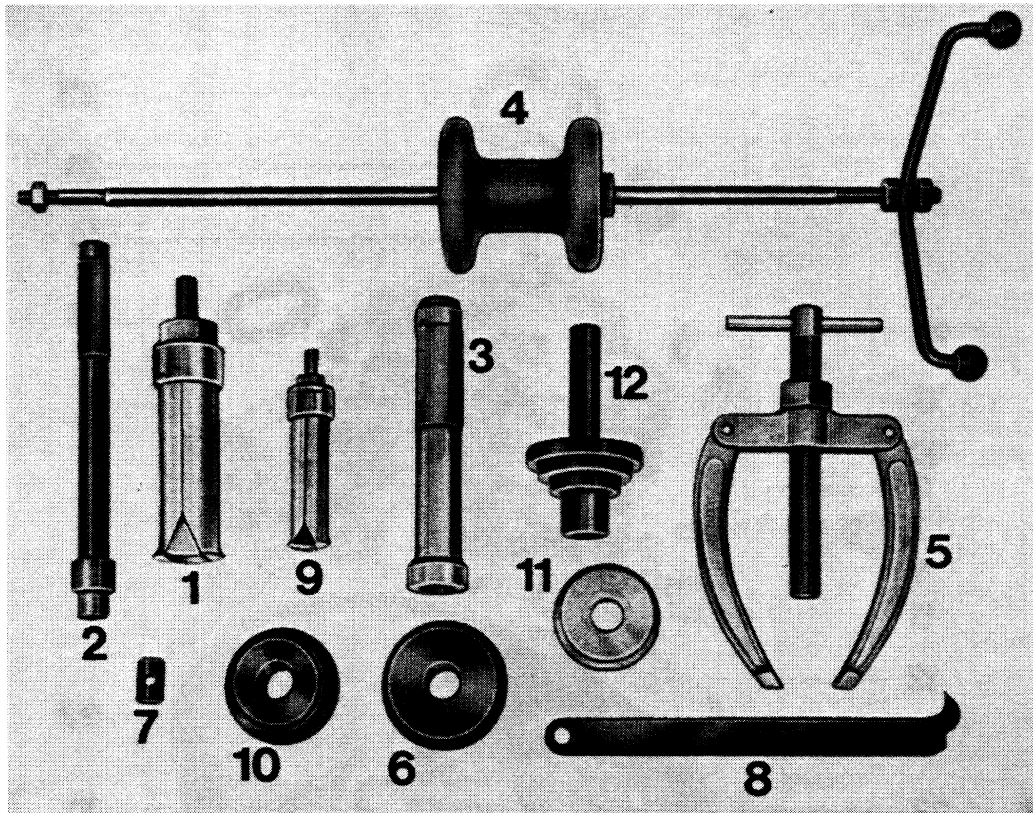

| No. | Description                | Special Tool | Remarks                    |
|-----|----------------------------|--------------|----------------------------|
| 1   | Internal puller 46 – 56 mm | US 1037      | Standard, e. g. Kukko 21/7 |
| 2   | Mandrel                    | VW 295       |                            |
| 3   | Mandrel                    | VW 30 - 21   |                            |
| 4   | Slide hammer               | VW 771       |                            |
| 5   | Spindle                    | US 1039      | Standard, e. g. Kukko 22/2 |
| 6   | Thrust pad                 | VW 2050      |                            |
| 7   | Threaded sleeve            | VW 771/15    |                            |
| 8   | Puller                     | VW 681       |                            |
| 9   | Internal puller 30 – 37 mm | US 1108      | Standard, e. g. Kukko 21/5 |
| 10  | Thrust pad                 | VW 511       |                            |
| 11  | Thrust pad                 | VW 30 - 205  |                            |
| 12  | Mandrel                    | VW 2062      |                            |

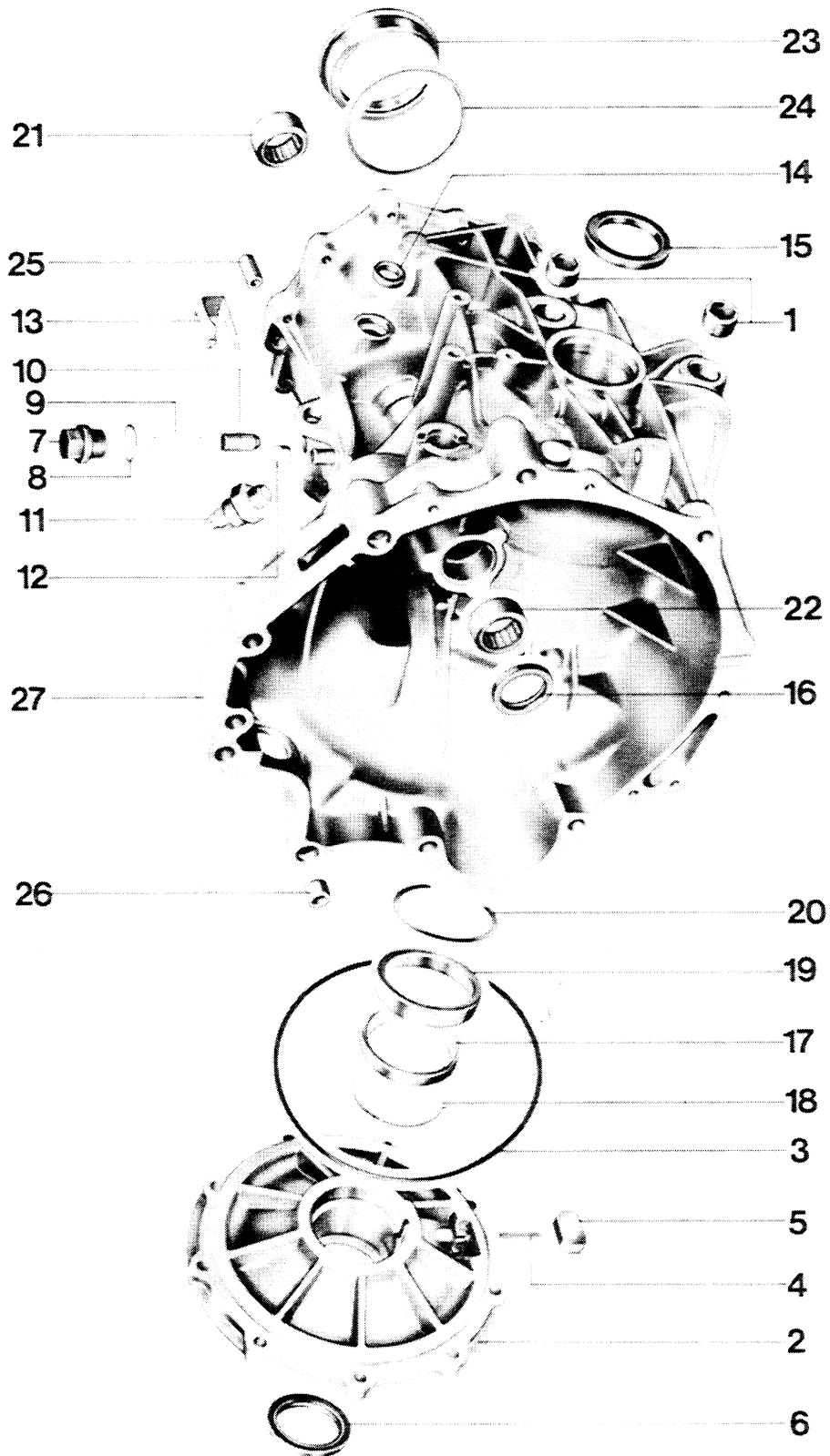

| No. | Description         | Qty. | Note When:  |   | Special Instructions |
|-----|---------------------|------|---|---|----------------------|
|     |                     |      | Removing  | Installing  |                      |
| 1   | Plug                | 2    |   | Torque: 25 Nm   | Page 34 - 43         |
| 2   | Final drive cover   | 1    |   | Adjust after replacing gear ring  |                      |
| 3   | Seal                | 1    |   | Replace, give a light coat of oil   |                      |
| 4   | Clamping sleeve     | 1    |   |   |                      |
| 5   | Magnet              | 1    |   | Clean   |                      |
| 6   | Seal                | 1    | Pull out with VW 681  | Drive in to stop with VW 2062. Pack space betw. sealing lips with multi-purpose grease. |                      |
| 7   | Threaded sleeve     | 1    |   | Torque: 30 Nm   |                      |
| 8   | Gasket              | 1    |   | Replace   |                      |
| 9   | Spring              | 1    |   |   |                      |
| 10  | Bushing             | 1    |   |   |                      |
| 11  | Backup light switch | 1    |   | Torque: 30 Nm   |                      |
| 12  | Cap                 | 1    | Pull off  |   |                      |
| 13  | Deflector           | 1    | Press down retainer with a small screwdriver applied in vent pipe and pull out deflector. | Engage retainer in pipe of vent.  |                      |
| 14  | Seal                | 1    | Pull out with VW 681.   | Replace; pack space between sealing lips with multi-purpose grease.                     |                      |



| No. | Description                       | Qty. | Note When:                            |  | Special Instructions |
|-----|-----------------------------------|------|---------------------------------------|--|----------------------|
|     |                                   |      | Removing                              | Installing   |                      |
| 15  | Seal                              | 1    | Pull out with VW 681                  | Drive in to stop with VW 2062. Pack space betw. sealing lips with multi-purpose grease.  |                      |
| 16  | Seal                              | 1    | Pull out with VW 681                  | Give sealing lip a light coat of oil drive into case to depth of 1.5 mm with a suitable pipe. First install gear set to avoid damaging seal. |                      |
| 17  | Tapered roller bearing outer race | 1    | Pull out with internal puller         | Press in with VW 30-205  |                      |
| 18  | Shim S2                           | X    | Note thickness for installation later | Determine new thickness if necessary   |                      |
| 19  | Tapered roller bearing outer race | 1    | Pull out with internal puller         | Drive in with VW 511 and VW 295  |                      |
| 20  | Shim S1                           | X    | Note thickness for installation later | Determine new thickness if necessary   |                      |
| 21  | Needle bearing                    | 1    | Drive out with VW 771                 | Do not mix up with needle bearing no. 23. Drive in flush with VW 30-21.  |                      |
| 22  | Needle bearing                    | 1    | Drive out with VW 771                 | Do not mix up with needle bearing no. 21. Drive in to stop with VW 30-21.  |                      |

| No. | Description                       | Qty. | Note When:   |   | Special Instructions |
|-----|-----------------------------------|------|--|---|----------------------|
|     |                                   |      | Removing   | Installing                                      |                      |
| 23  | Tapered roller bearing outer race | 1    | When replacing, measure installed position (actual distance) of drive pinion before removing. Drive out with VW 2050 and VW 771. | Heat case and press in with VW 2050 and VW 295. |                      |
| 24  | Shim S3                           | 1    | Note thickness for installation later  | Determine new thickness if necessary            |                      |
| 25  | Dowel sleeve                      | 2    |  |   |                      |
| 26  | Dowel sleeve                      | 2    |  |   |                      |
| 27  | Transmission case                 | 1    | When replacing, measure installed position (actual distance) of drive pinion before disassembling.                               |   |                      |

#### Note

The seal (No. 3) and its groove in the cover have been omitted since June, 1984. Sealing is now accomplished with Loctite No. 573 or 574.

## DISASSEMBLING AND ASSEMBLING TRANSMISSION CASE

## Disassembling

1. Pull out seal for flange shaft with Special Tool VW 681.

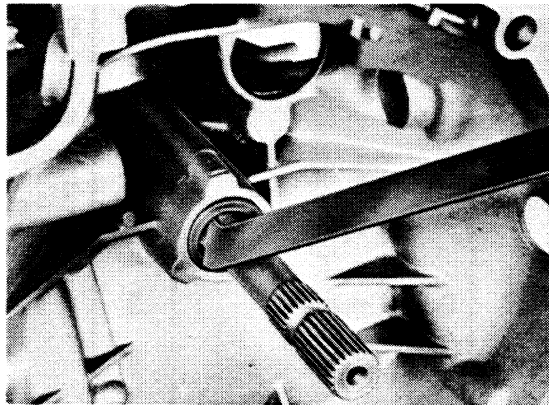
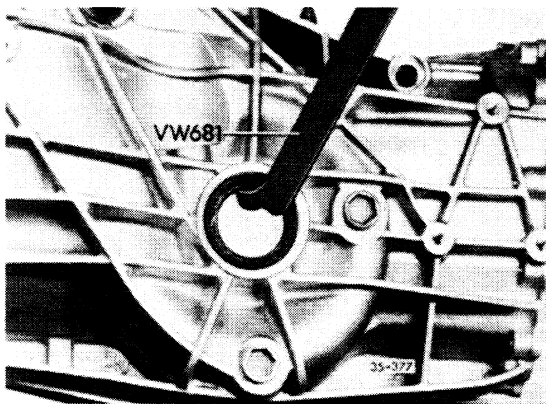

2. Pull out seal for selector shaft with Special Tool VW 681.

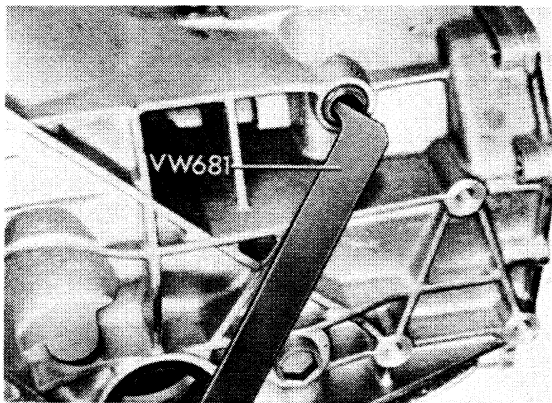

4. Remove front needle bearing for input shaft with an internal claw puller, e. g. Kukko 21/5, Special Tool VW 771 and Special Tool VW 771/15.

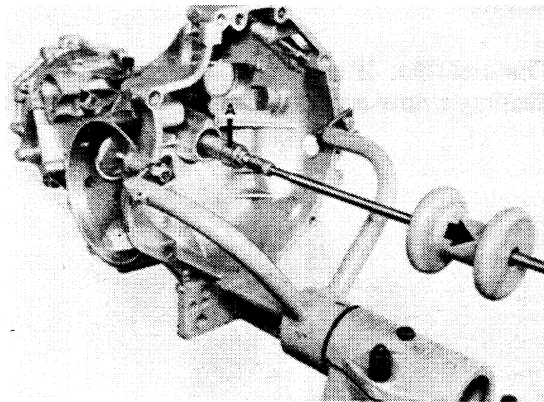

A = Internal claw puller

3. Pull out seal for input shaft with Special Tool VW 681.

5. Remove rear needle bearing for input shaft with an internal claw puller, e. g. Kukko 21/5, Special Tool VW 771 and Special Tool VW 771/15.

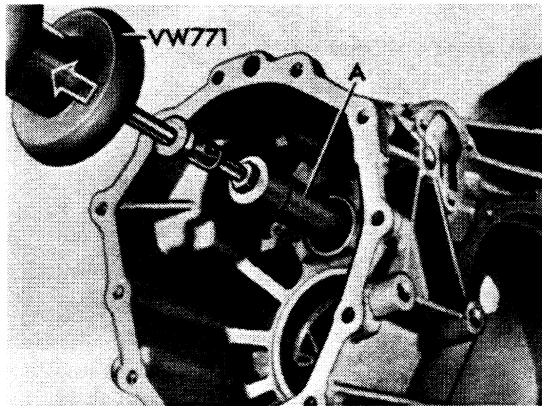

A – Internal claw puller

6. Drive out tapered roller bearing outer race for drive pinion with Special Tools VW 2050 and VW 771.

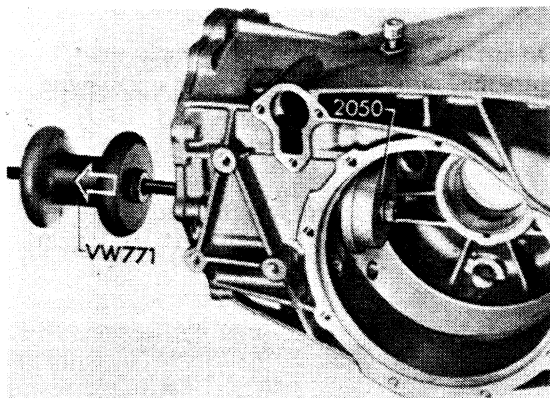

#### Note

Heat case for removal of outer race, since tapered roller bearing outer race has a tight press-fit in the case.

7. Pull out outer race for small tapered roller bearing. Use a 46 to 56 mm internal claw puller and spindle for this step.

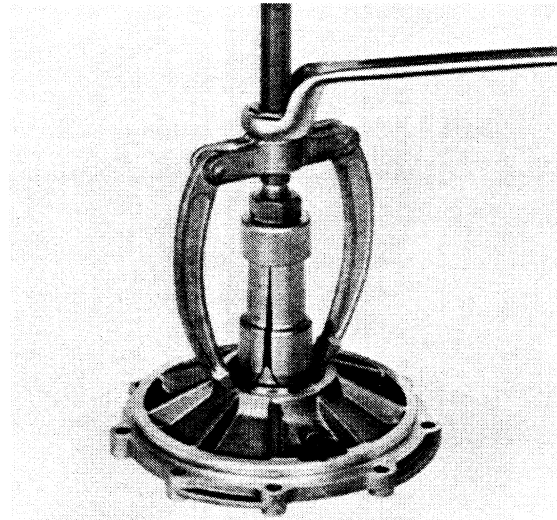

8. Pull out outer race of large tapered roller bearing with a 46 to 56 mm internal claw puller and spindle.

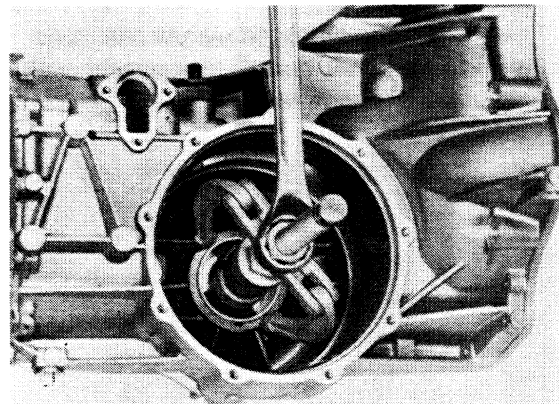

#### Assembling

#### Note

It is essential to heat the transmission case thoroughly prior to installation of the outer race, since the tapered roller bearing outer race for the drive pinion must be installed in the case with a very tight press-fit. In order to be able to install the outer race without problems, case temperature must be at least 150 °C (300 °F). Temperatures up to 180 °C (350 °F) will not damage the case. Heat from hot water stream or washing machine will not be sufficient.

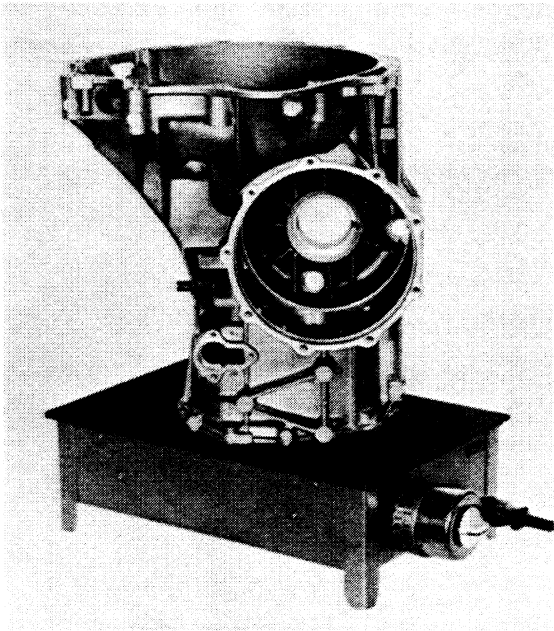

1. Install tapered roller bearing outer race for drive pinion in the heated case. Always work with a press to avoid tilted.  
Use Special Tools VW 2050 and VW 295. Hold preload under press about 2 more minutes until heat has been transferred.

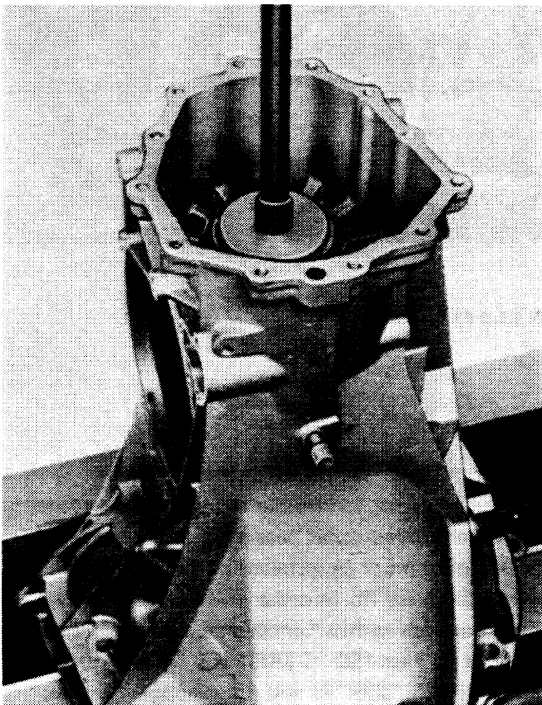

2. Drive in rear needle bearing for input shaft flush. Use Special Tool VW 30 - 21.

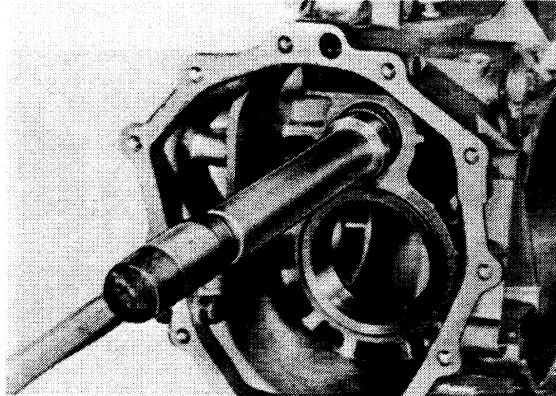

3. Drive in front needle bearing for input shaft against stop. Use Special Tool VW 30 - 21.

Installed position: lettering on needle bearing faces special tool.

#### Note

Do not mix up needle bearings for input shaft, since they differ in outside diameter and number of needles.

4. Press in outer race for large tapered roller bearing. Use Special Tools VW 511 and VW 295.

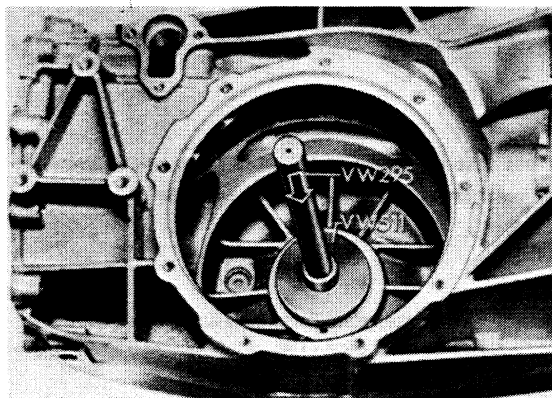

5. Press in outer race for small tapered roller bearing (in side cover). It is recommended to heat to cover. Use Special Tools VW 30 - 205 and VW 295.

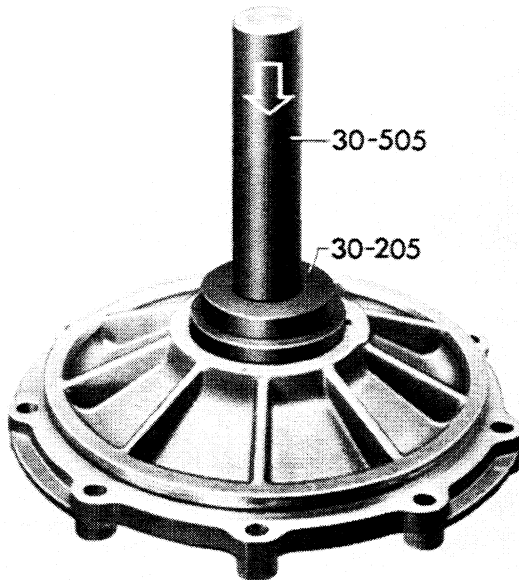

#### Note

It is recommended to install the seals for flange shafts only after installation of the differential to avoid damage.

7. Drive in seal for selector shaft against stop with a suitable mandrel (e. g. VW 423).

6. Drive in seal for flange shaft against stop with Special Tool VW 2062.

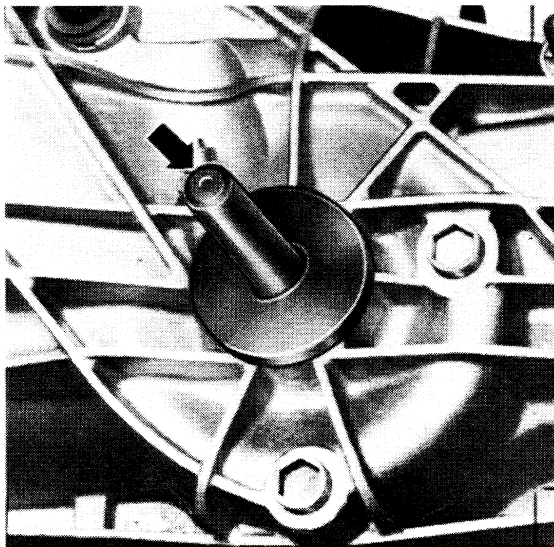

## TOOLS

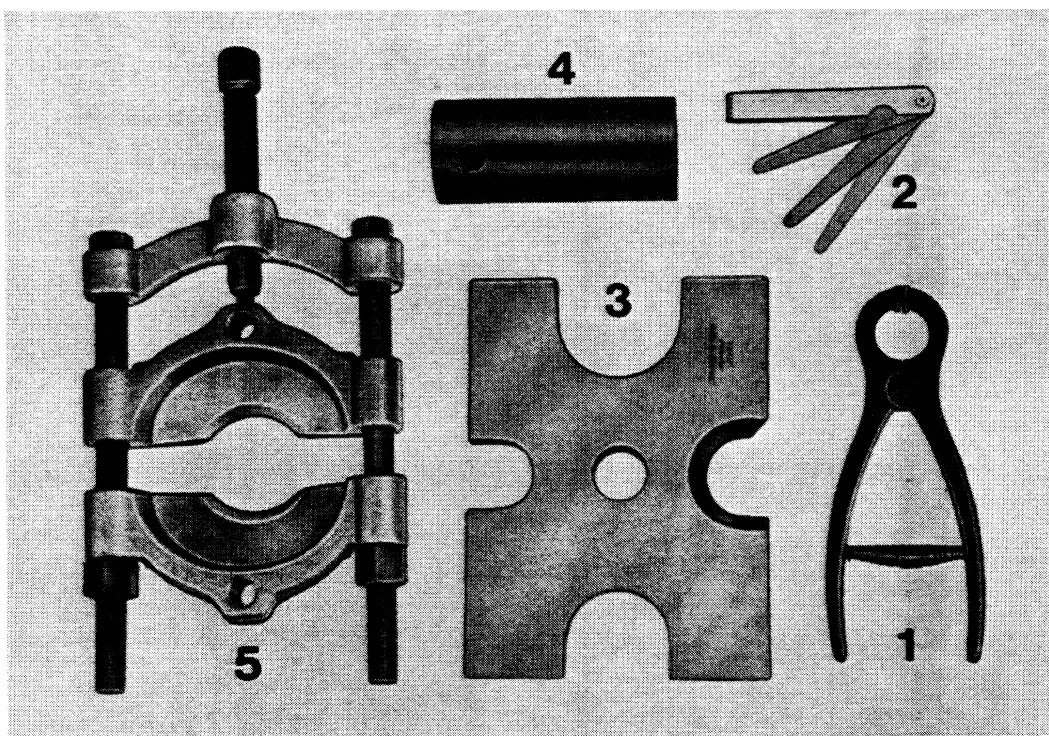

| No. | Description        | Special Tool | Remarks  |
|-----|--------------------|--------------|----------|
| 1   | Circlip pliers     | VW 161 a     | Standard |
| 2   | Feeler blade gauge |              |          |
| 3   | Press plate        | VW 401       |          |
| 4   | Pipe               | VW 519       |          |
| 5   | Separator          | US 1103      |          |

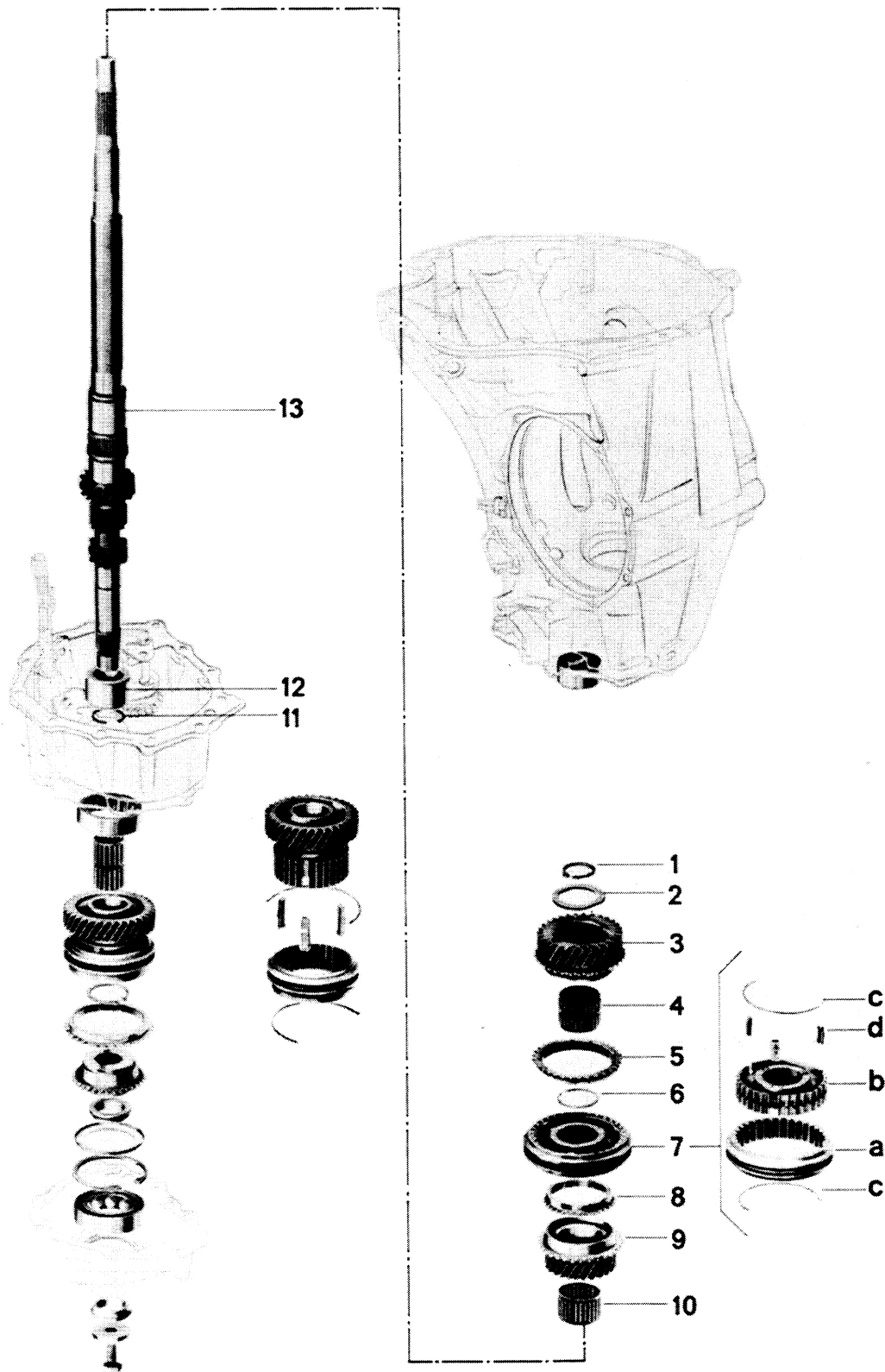



| No. | Description  | Qty. | Note When:              |   | Special Instructions |
|-----|--|------|-------------------------|---|----------------------|
|     |  |      | Removing                | Installing  |                      |
| 1   | Circlip  | 1    |                         | Determine new thickness   |                      |
| 2   | Thrust ring*   | 1    |                         |   |                      |
| 3   | Fourth gear  | 1    |                         | Adjust axial play   |                      |
| 4   | Needle bearing   | 1    |                         | Lubricate with gear lube  |                      |
| 5   | Synchromesh ring for 4th gear                          | 1    |                         | Spray molybdenum on friction surface. Check for wear.                 |                      |
| 6   | Circlip  | 1    |                         | Determine new thickness   |                      |
| 7   | Synchronizer with sliding sleeve for 3rd and 4th gears | 1    | Press off with 3rd gear | Position correctly<br>Check axial play                                |                      |
| 7a  | Sliding sleeve   | 1    |                         |   |                      |
| 7b  | Synchronizer   | 1    |                         |   |                      |
| 7c  | Spring   | 2    |                         | Position correctly  |                      |
| 7d  | Lock   | 3    |                         |   |                      |
| 8   | Synchromesh ring for 3rd gear                          | 1    |                         | Spray molybdenum on friction surface. Check for wear.                 |                      |
| 9   | Third gear   | 1    |                         | Check axial play betw. 2nd and 3rd gears                              |                      |
| 10  | Needle bearing   | 1    |                         | Lubricate with gear lube  |                      |
| 11  | Circlip  | 1    |                         | Measure and install only after installing input shaft and inner race. |                      |
| 12  | Inner race   | 1    |                         | Install only after installing input shaft                             |                      |
| 13  | Input shaft  | 1    |                         |   |                      |

\* Since September, 1983 the thrust ring (No. 2) has been omitted. The circlip (No. 1) and recess in the input shaft were also changed.  
Old and new parts or vice versa may not be installed with each other for repairs.  
Adjusting the axial play on the fourth gear has been omitted.

## DISASSEMBLING AND ASSEMBLING INPUT SHAFT

## Disassembling

1. Press off sliding sleeve/synchronizer with third gear.

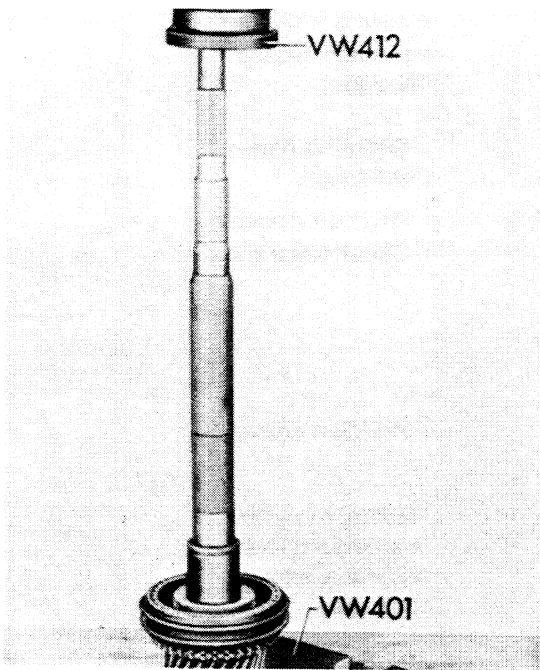

## Assembling

1. Assemble sliding sleeve and synchronizer for 3rd and 4th gears. It is not necessary to have a pair in a certain position, however, groove in synchronizer or wide collar of hub must face 4th gear.

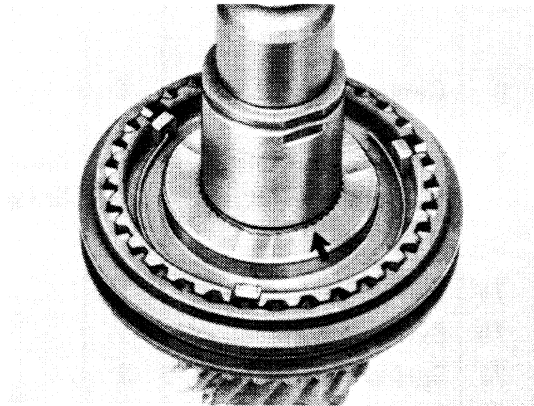

2. Mount springs with 120° offset. Angled end of spring must engage in hollow lock.

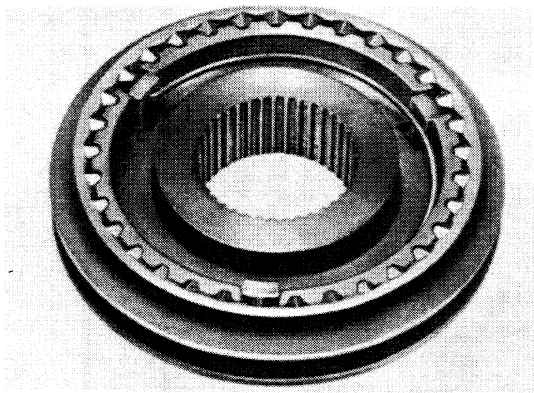

3. Press on sliding sleeve with synchronizer body in correct position, turning synchromesh ring so that grooves are aligned with locks.

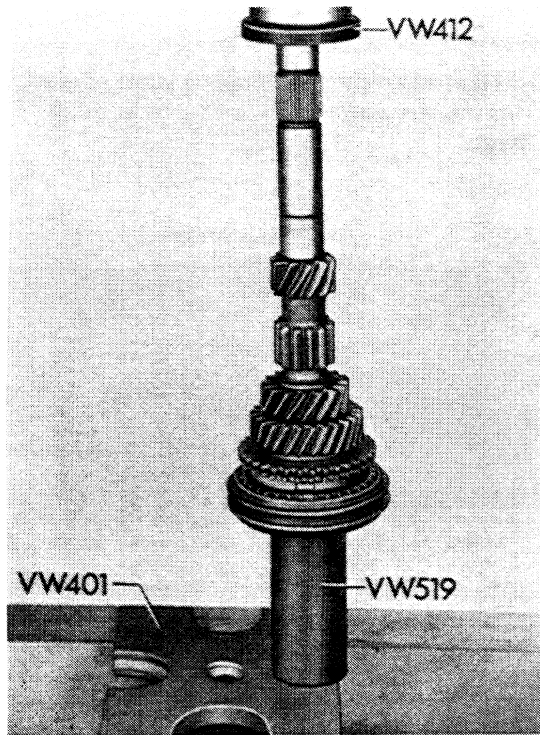

#### Note

Groove in synchronizer body or wide collar of hub faces 4th gear.

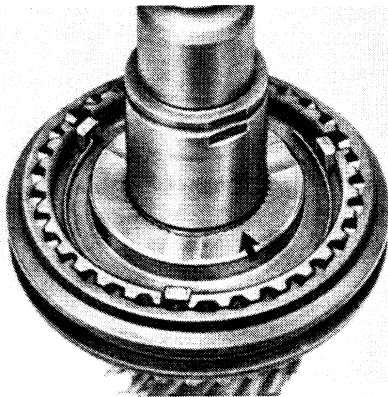

4. Measure axial play of synchronizer body with a feeler gauge blade and adjust by selecting a pertinent circlip. It should be between 0 and 0.05 mm, whereby the lower value would be ideal.

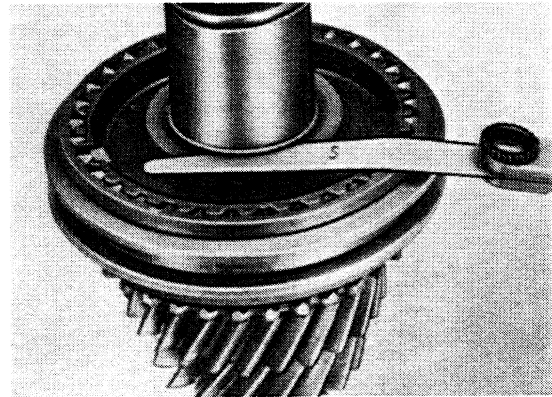

Circlips available:

| Part Number   | Thickness (mm) |
|---------------|----------------|
| 088 311 317   | 1.50           |
| 088 311 317 B | 1.56           |
| 088 311 317 C | 1.62           |

5. Measure play between 2nd and 3rd gears.  
Nominal value: 0.1 to 0.35 mm.  
If this tolerance cannot be reached, recheck adjustment of synchronizer.

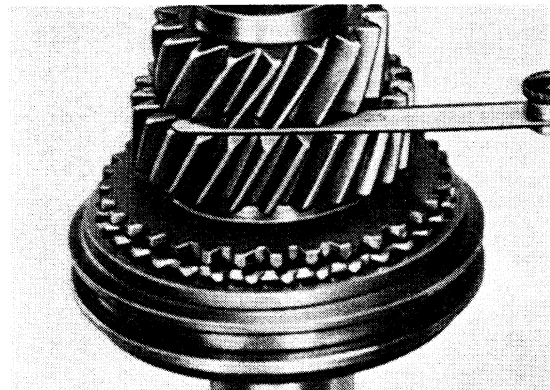

6. Measure axial play on 4th gear with a feeler gauge blade and adjust with a pertinent circlip. Play should be between 0.20 and 0.35 mm, whereby lower value would be ideal.

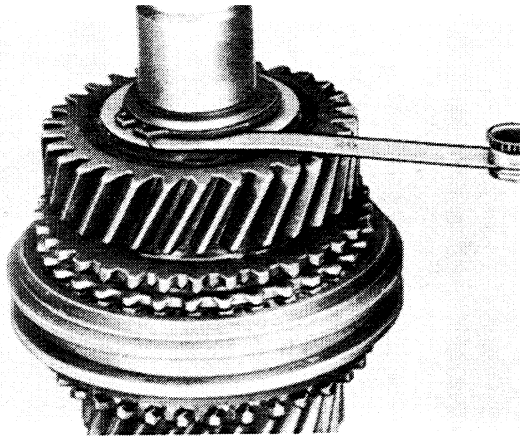

### Checking Synchronizer Rings

1. Clean synchronizer rings and gears.
2. Press dried synchronizer rings on tapers of gears and measure clearance "a" with a feeler gauge blade.

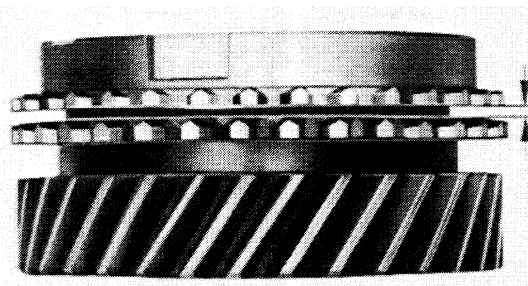

Circlips available:

| Part Number   | Thickness (mm) |
|---------------|----------------|
| 088 311 287   | 1.65           |
| 088 311 287 A | 1.70           |
| 088 311 287 B | 1.75           |

| Clearance "a"    | New Distance (mm) | Wear Limit (mm) |
|------------------|-------------------|-----------------|
| 3rd and 4th gear | 1.0 to 1.7        | 0.5             |
| 5th gear         | 1.0 to 1.9        | 0.5             |

## TOOLS

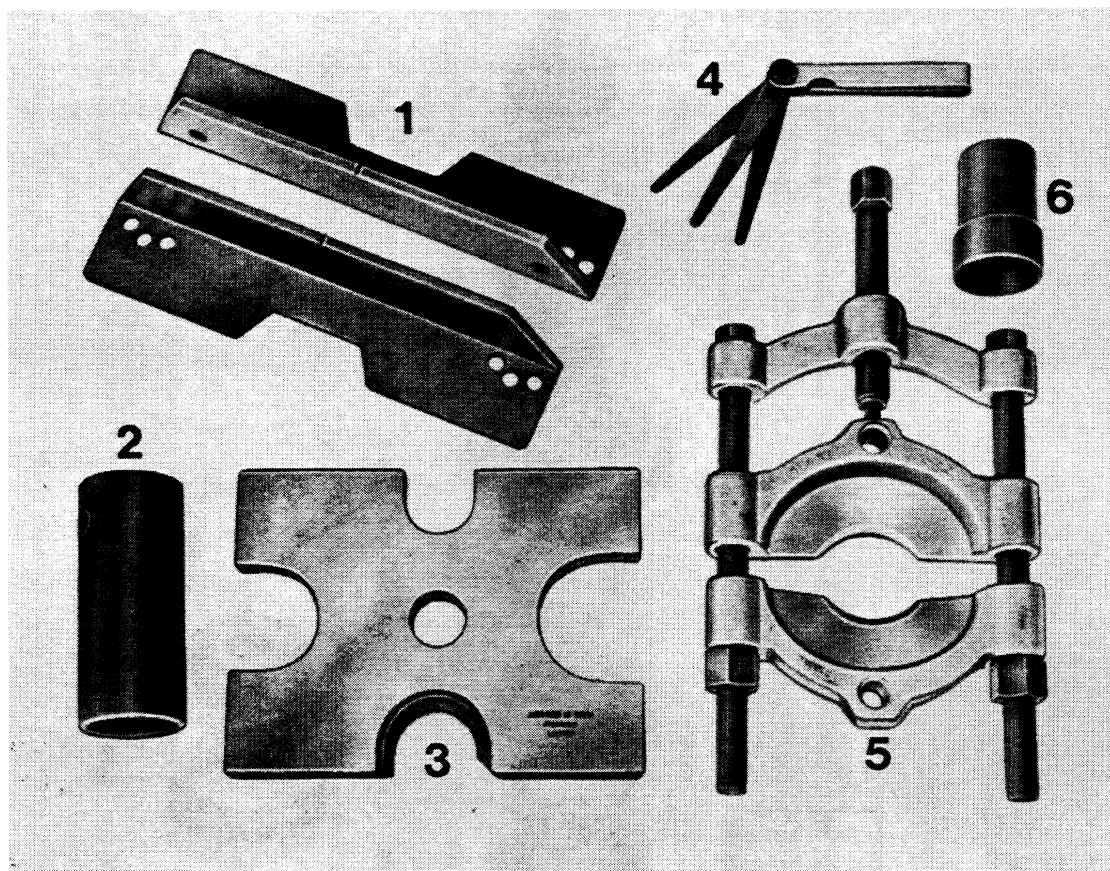

| No. | Description        | Special Tool | Remarks                   |
|-----|--------------------|--------------|---------------------------|
| 1   | Support rail       | VW 457       |                           |
| 2   | Pipe               | VW 519       |                           |
| 3   | Thrust pad         | VW 401       |                           |
| 4   | Feeler blade gauge | -            | Standard                  |
| 5   | Separator          | US 1103      | e. g. Kukko 15 - 17 Gr. 1 |
| 6   | Thrust pad         | VW 454       |                           |

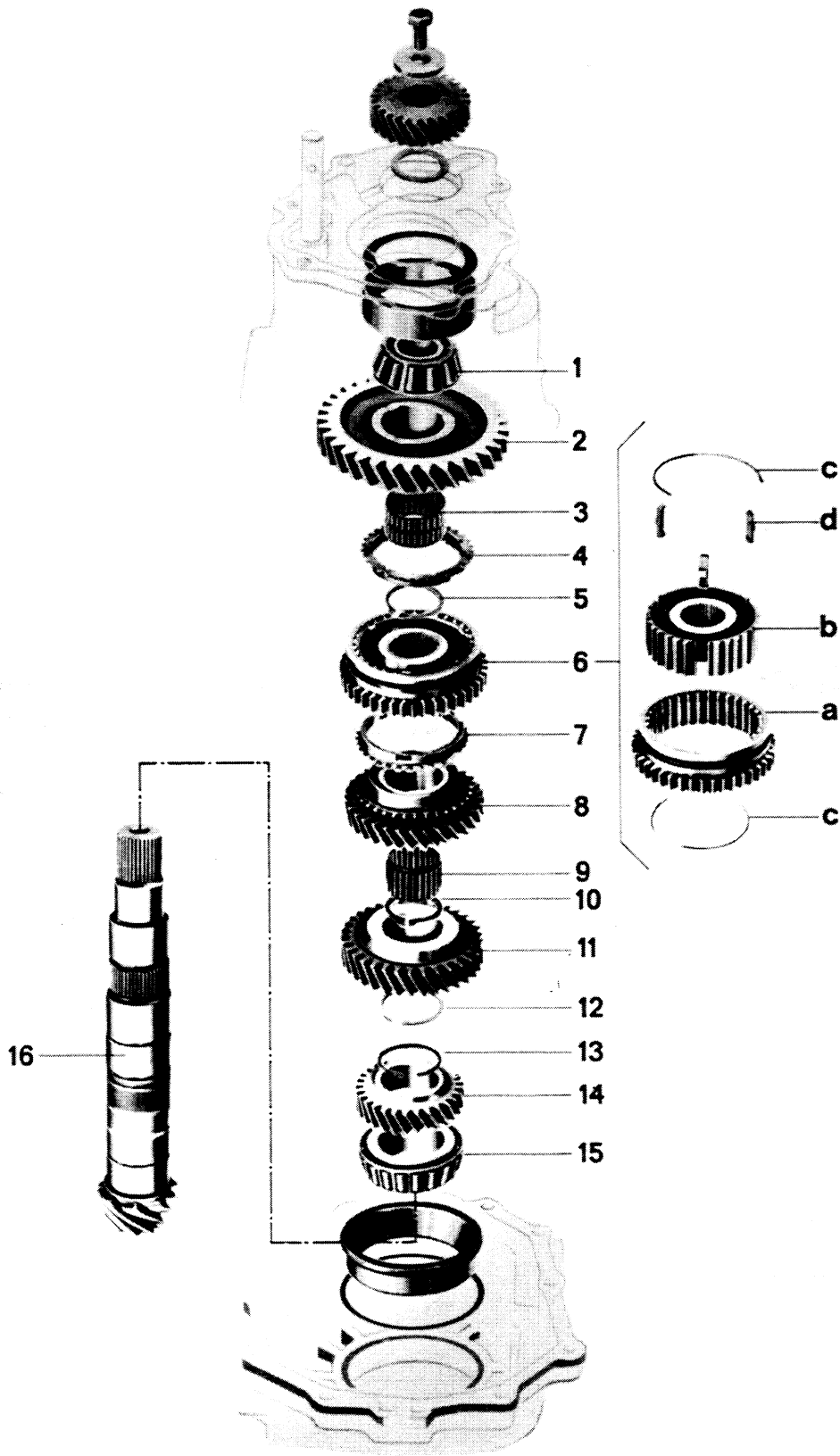

| No. | Description  | Qty. | Note When:            |  | Special Instructions |
|-----|--|------|-----------------------|--|----------------------|
|     |  |      | Removing              | Installing   |                      |
| 1   | Tapered roller bearing                                 | 1    | Press off with VW 457 | If necessary, replace both bearings together. Use same make  |                      |
| 2   | 1st gear   | 1    |                       | Check axial play   |                      |
| 3   | Needle bearing   | 1    |                       | Lubricate with gear lube   |                      |
| 4   | Synchronizer ring for 1st gear                         | 1    |                       | Angle 110°. Identification: each 3 x 1 tooth missing. Friction surfaces coated with molybdenum and spiral groove. Check for wear |                      |
| 5   | Circlip  | 1    |                       | Determine new thickness  |                      |
| 6   | Synchronizer with sliding sleeve for 1st and 2nd gears | 1    |                       |  |                      |
| 6a  | Sliding sleeve   | 1    |                       |  |                      |
| 6b  | Synchronizer body                                      | 1    |                       |  |                      |
| 6c  | Spring   | 2    |                       | Position correctly   |                      |
| 6d  | Lock   | 3    |                       |  |                      |
| 7   | Synchronizer ring for 2nd gear                         | 1    |                       | Angle 115°, friction surface coated with molybdenum and spiral groove  |                      |
| 8   | 2nd gear   | 1    |                       |  |                      |
| 9   | Needle bearing   | 1    |                       | Lubricate with gear lube   |                      |
| 10  | Circlip  | 1    |                       | Determine new thickness  |                      |

| No. | Description            | Qty. | Note When:               |   | Special Instructions |
|-----|------------------------|------|--------------------------|---|----------------------|
|     |                        |      | Removing                 | Installing  |                      |
| 11  | 3rd gear *             | 1    |                          | Check for wear.<br>Install warm and press on. Large collar faces 2nd gear. Adjust axial play. |                      |
| 12  | Circlip *              | 1    |                          | Thickness always 2.4 mm   |                      |
| 13  | Circlip *              | 1    |                          | Determine new thickness   |                      |
| 14  | 4th gear *             | 1    |                          | Check for wear. Install warm and press on. Large collar faces 3rd gear. Adjust axial play.    |                      |
| 15  | Tapered roller bearing | 1    | Press off with separator | If necessary, replace both together.<br>Use same make.  |                      |
| 16  | Pinion shaft *         | 1    |                          | Check for wear.<br>Paired with ring gear. Adjust pinion/ring gear after replacing parts.      |                      |

\* Beginning with 1983 models the 4th gear was changed from press-fit to spline-fit. This change also affected 3rd gear, pinion shaft and circlips.



## DISASSEMBLING AND ASSEMBLING PINION SHAFT

## Note

When replacing tapered roller bearings, check installed position of pinion shaft (actual location) before removing the gear carrier.

## Disassembling

1. Press off inner race of tapered roller bearing with 1st gear. Use Special Tool VW 457.

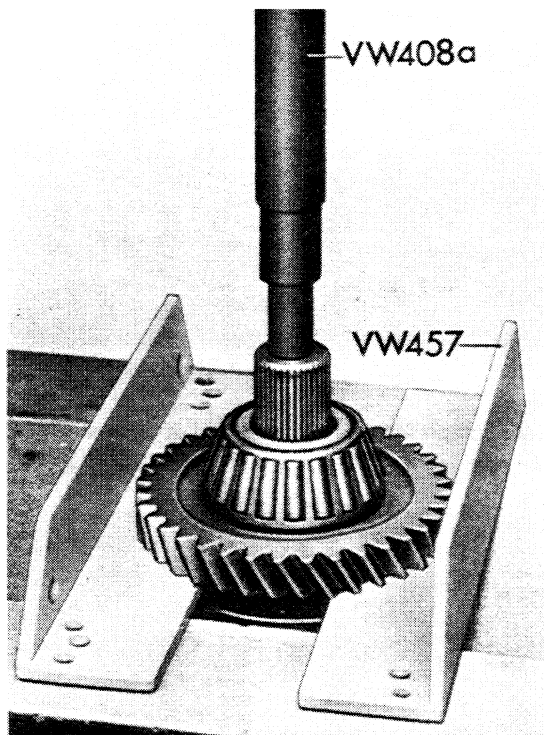

2. Press off sliding sleeve and synchronizer with 2nd gear. Use Special Tool VW 457.

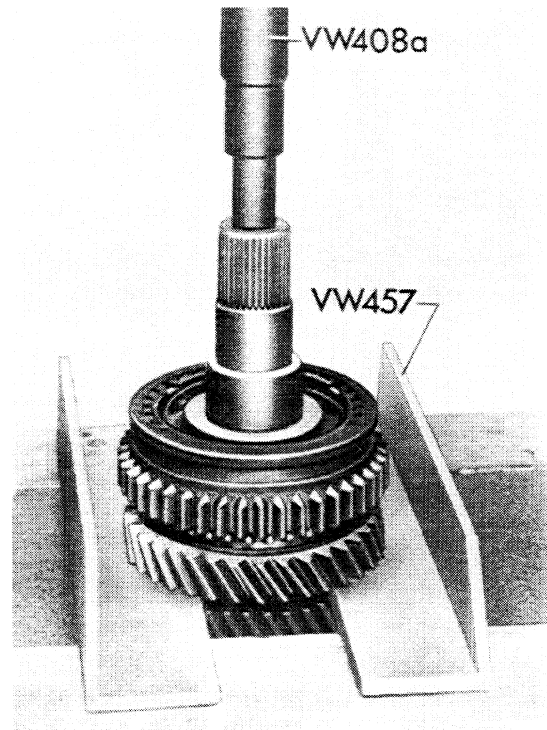

3. Press off 3rd gear.

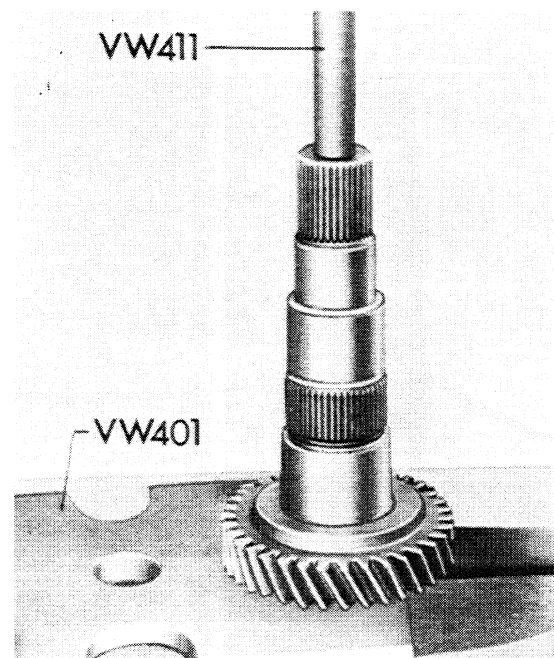

4. Press off 4th gear with a separator, e. g. Kukko 15 - 17 Gr. 1.

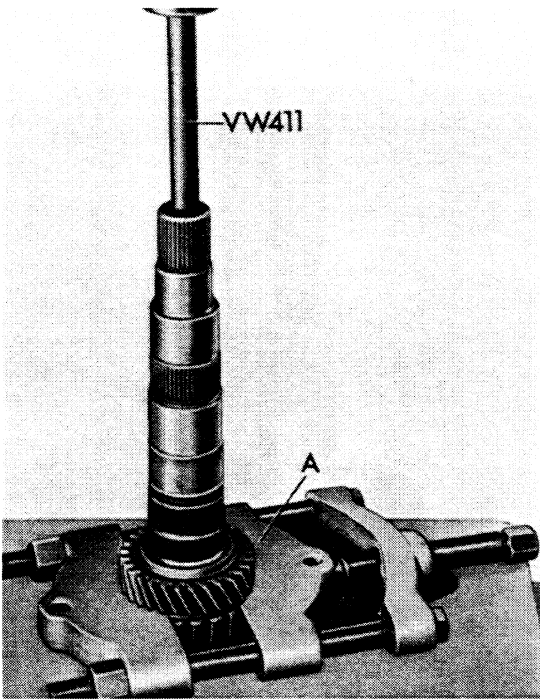

5. Press off inner race for tapered roller bearing with a separator, e. g. Kukko 15 - 17 Gr. 1.

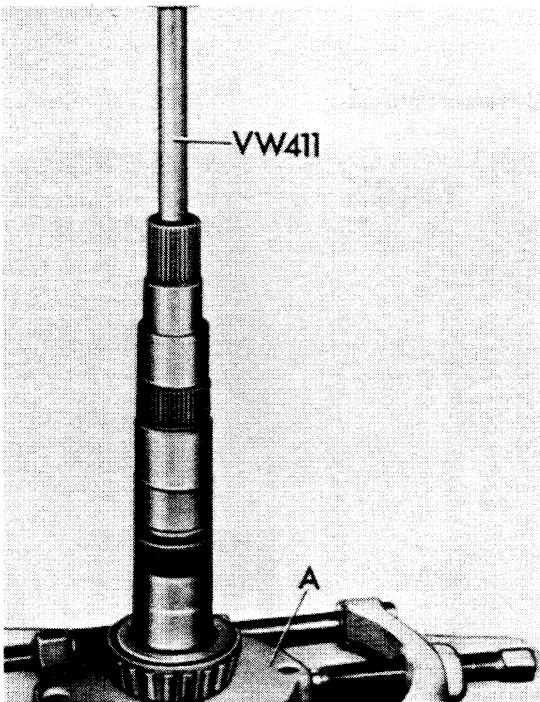

A – Separator

Assembling

1. Heat inner race for tapered roller bearing to about 120 °C (250 °F) and press on.

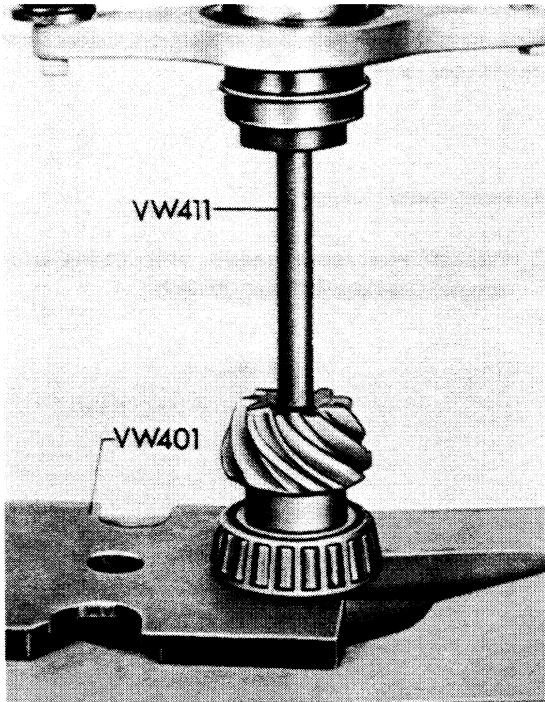

2. Press on 4th gear, whereby collar faces 3rd gear.

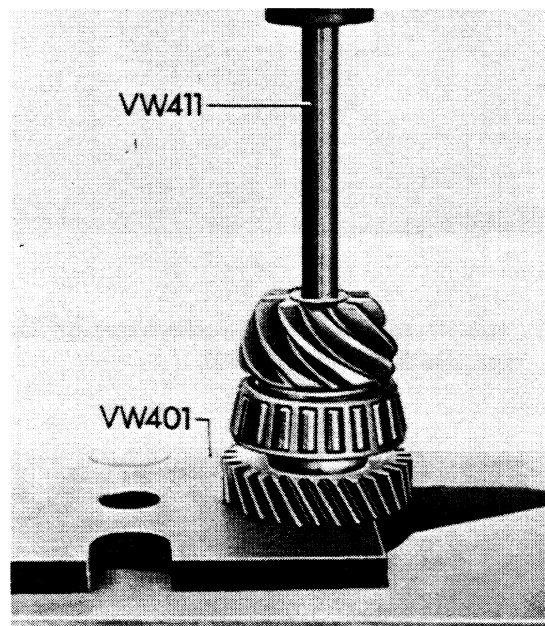

**Note**

It is essential to keep to the following procedures, since the press-fit gear takes the engine torque.

Clean gear and shaft with a greaseless cleaning solution to remove all oil and grease, and heat gear on a hot plate to about 120 °C (250 °F).

Press on gear and press again after transfer of heat (approx. 3 minutes).

3. Adjust axial play on 4th gear (gear must be cold and pressed against stop).  
Measure and install the thickest possible circlip.  
Axial play may be max. 0.02 mm.

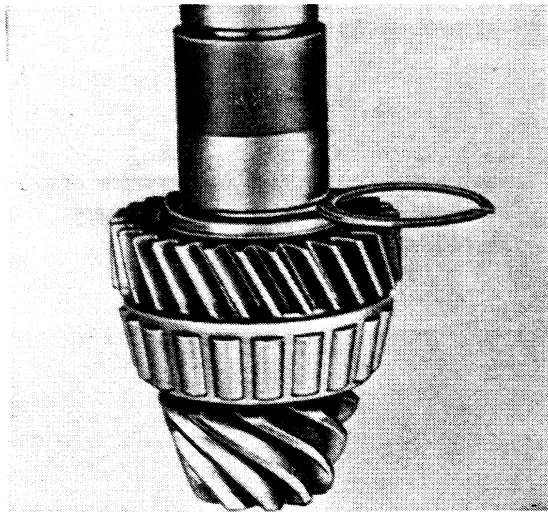
**Note**

Perform work very conscientiously, since otherwise service life of tapered roller bearings could be impaired.

Circlips available:

| Part Number   | Thickness (mm) |
|---------------|----------------|
| 016 311 363   | 2.24           |
| 016 311 363 A | 2.26           |
| 016 311 363 B | 2.28           |
| 016 311 363 C | 2.30           |
| 016 311 363 D | 2.32           |
| 016 311 363 E | 2.34           |
| 016 311 363 F | 2.36           |
| 016,311 363 G | 2.38           |
| 016 311 363 H | 2.40           |

4. Press on 3rd gear with collar facing 2nd gear.

**Note**

Clean gear and shaft with a greaseless cleaning solution to remove all oil and grease, and heat gear on a hot plate to approx. 120 °C (250 °F).

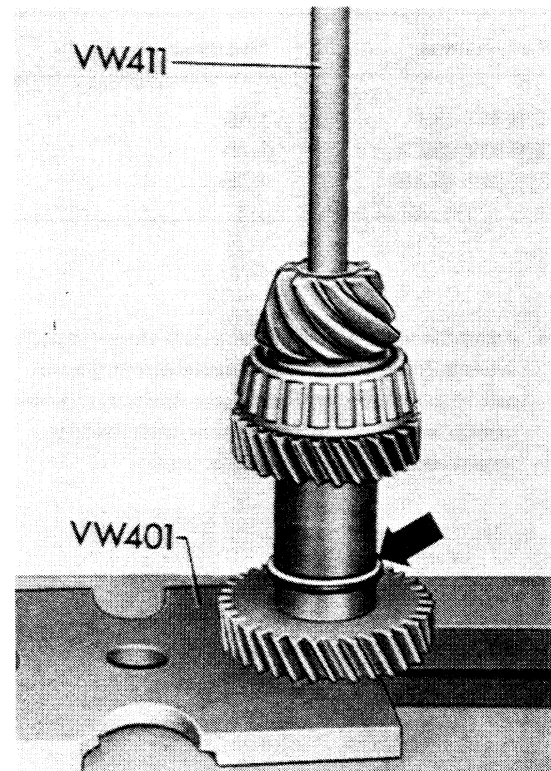

5. Adjust axial play on 3rd gear. Measure axial play on 3rd gear with a feeler gauge blade and correct to 0 . . . 0.04 mm by selecting a pertinent circlip. Lower value would be ideal.

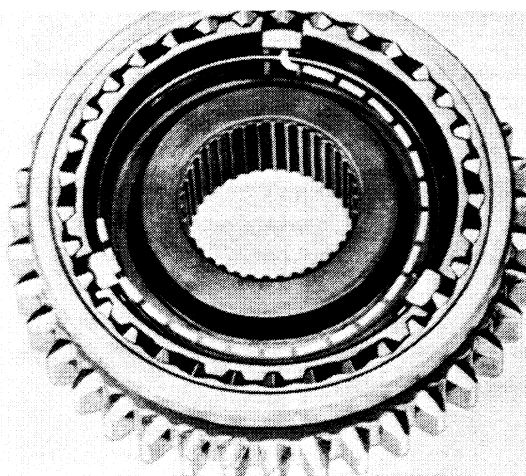
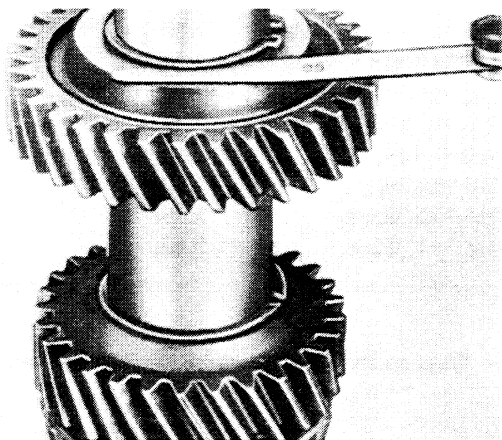

Circlips available:

| Part Number   | Thickness (mm) |
|---------------|----------------|
| 016 311 287   | 1.65           |
| 016 311 287 A | 1.70           |
| 016 311 287 B | 1.75           |

6. Assemble sliding sleeve and synchronizer body for 1st and 2nd gears. It is not necessary to have a pair in a certain position. Insert locks and install springs with 120° offset. Spring must have its angled end engaging in hollow lock.

#### Note

Coat molybdenum coated synchronesh rings with an approved transmission oil.

7. Press on sliding sleeve with synchronizer body. Turn synchronizer ring so that grooves are aligned with locks.

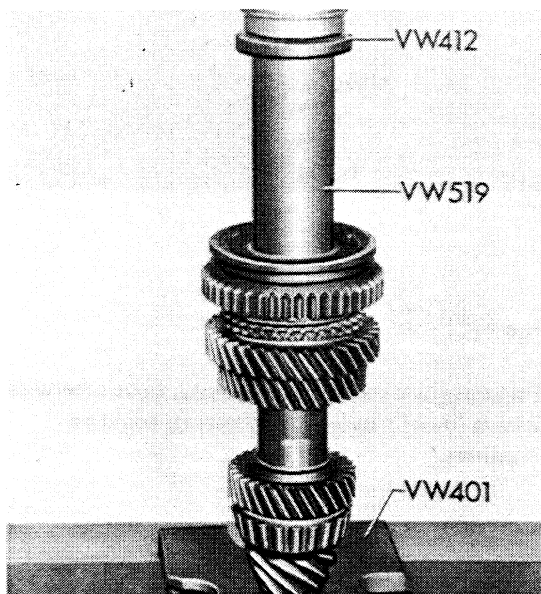

8. Adjust axial play on synchronizer body. Measure axial play of synchronizer body with a feeler gauge blade and correct to a value between 0 and 0.04 mm by selecting pertinent circlip. Lower value would be ideal.

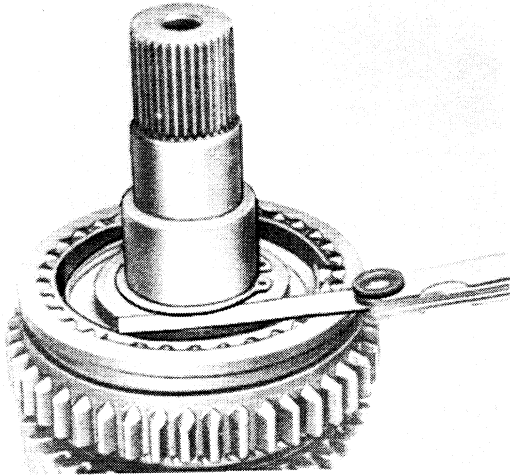

9. Press on inner race for tapered roller bearing.

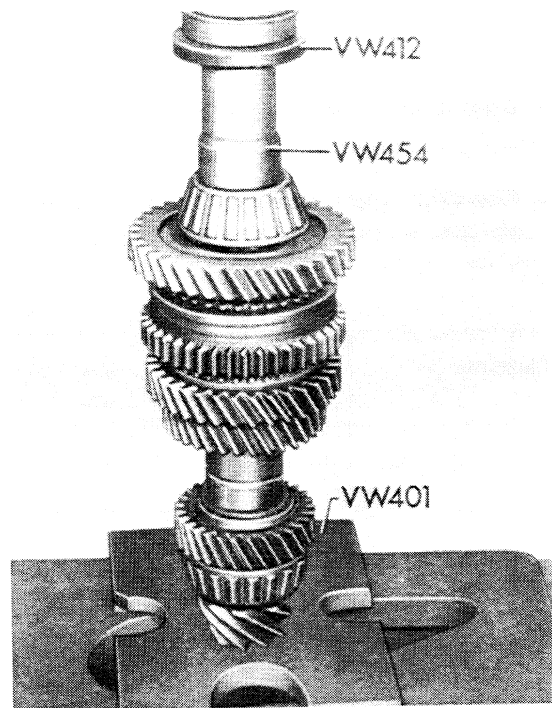

Circlips available:

| Part Number   | Thickness (mm) |
|---------------|----------------|
| 016 311 327   | 1.50           |
| 016 311 327 A | 1.55           |
| 016 311 327 B | 1.60           |

10. Measure play on 1st gear. Play should be between 0.10 and 0.40 mm. Recheck adjustment of synchronizer body if necessary. Parts must be pressed on against stop!

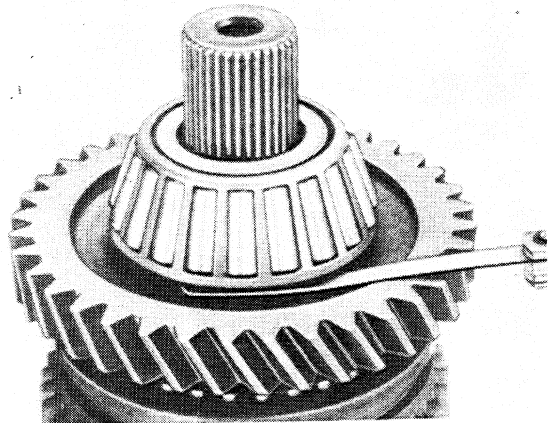

## Checking Synchronizer Rings

1. Clean synchronizer rings and gears.
2. Press dried synchronizer rings on tapers of gears and measure clearance "a" with a feeler gauge blade.

| Clearance "a"     | New Distance (mm) | Wear Limit (mm) |
|-------------------|-------------------|-----------------|
| 1st and 2nd gears | 1.0 to 1.7        | 0.5             |

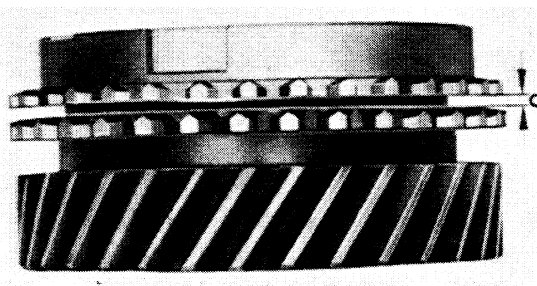

AUTOMATIC TRANSMISSION (Type 087)

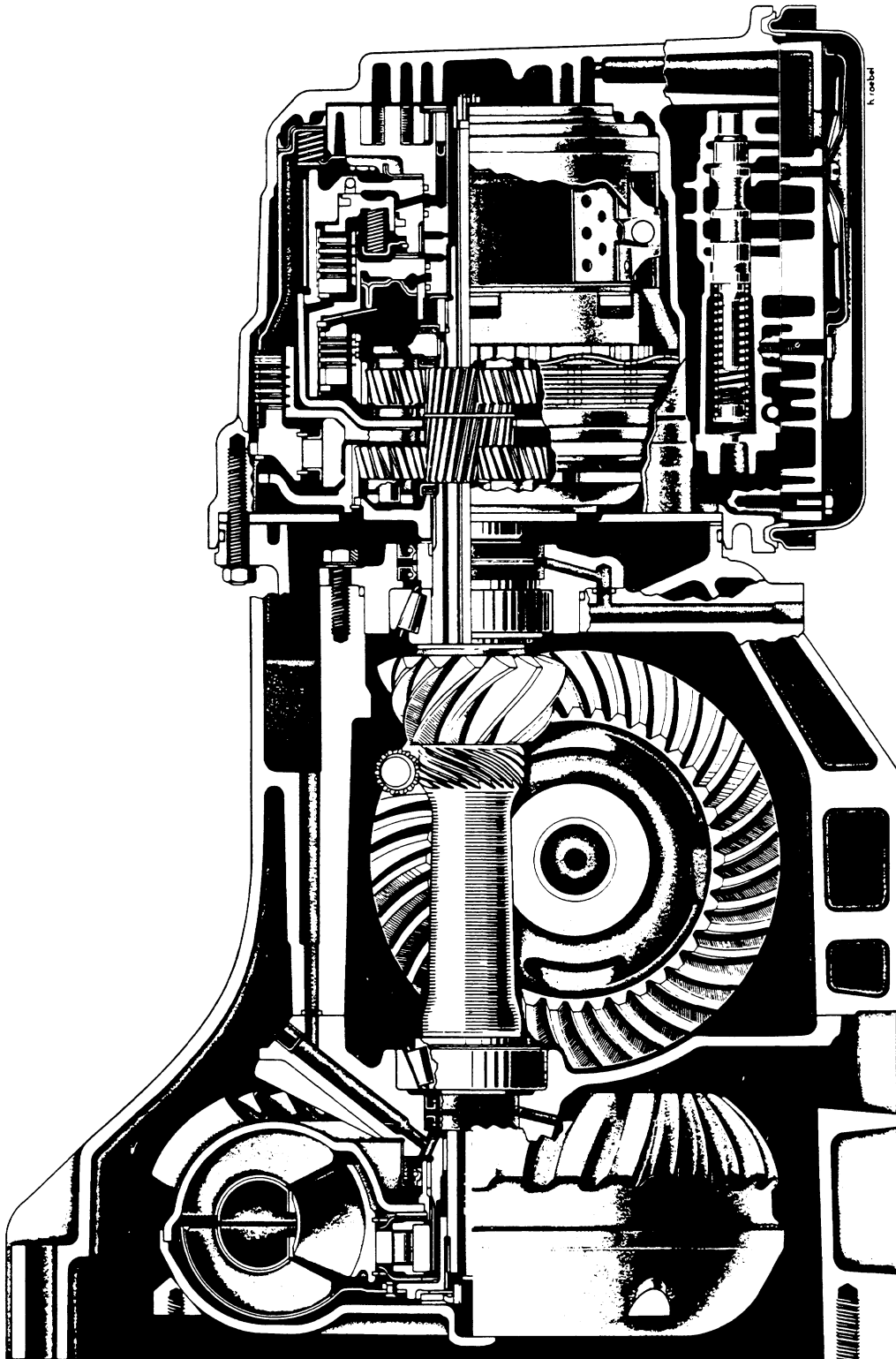

TRANSMISSION IDENTIFICATION

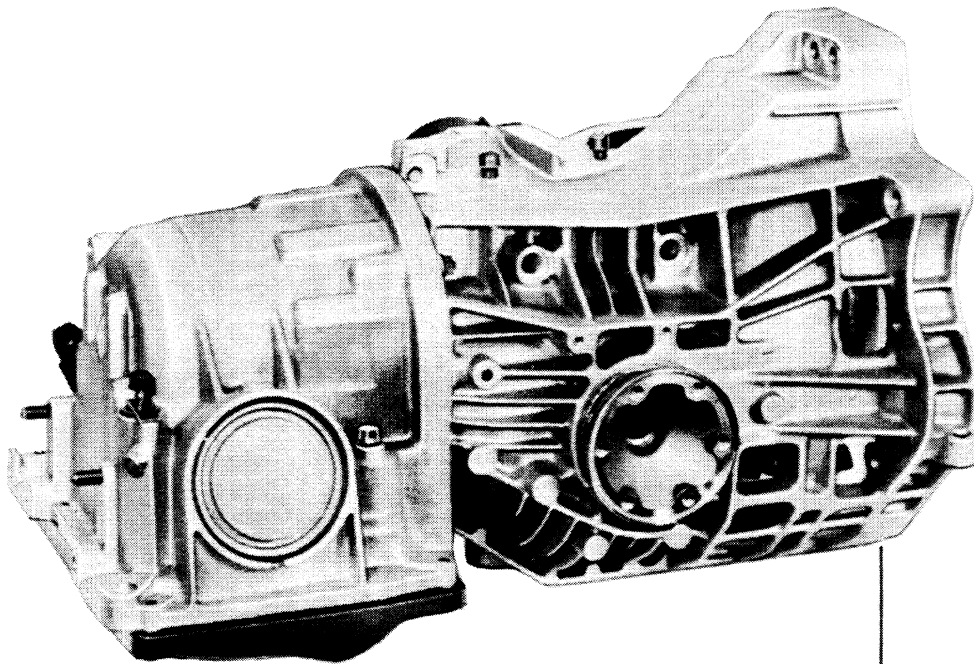

Code Letters and Mfg. Date of Transmission

Example:   RH   15   03   2

                  |    |    |    |

                  Code letters   Day   Month   Year (82)

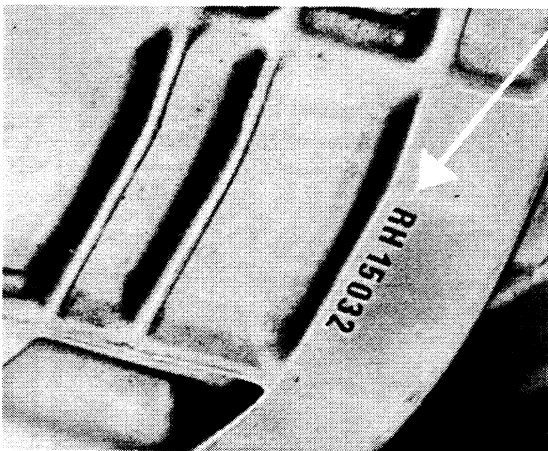



## TRANSMISSION - TYPES 944/924 S

| Transmission Type | Code Letters | installed in   |
|-------------------|--------------|--|
| 087 M             | RH           | 944 Eur., R.d.W. until September 82  |
| 087 M             | RCA          | 944 Eur., R.d.W. from October 82...12.21.83  |
| 087 M             | RCD          | 944 Eur., R.d.W. from December 83...<br>12.18.84<br>924 S - Eur./R.d.W. from Mod. 86 |
| 087 M             | RCE          | 944 Eur., R.d.W. from 12.19.84   |
| 087 N             | RCB          | 944 USA / Jap. from February 82...<br>12.18.84<br>924 S - USA/Jap. from 87 Model     |
| 087 N             | RCF          | 944 USA/Jap. from 12.19.84   |

## TECHNICAL DATA

|                           |  |                                 |
|---------------------------|--|---------------------------------|
| Internal code             | 087 M<br>(087 N)   |                                 |
| Number of gears           | 3 forward, 1 reverse and<br>parking lock   |                                 |
| Ratios                    | Type 087 M<br>and N<br>Code letter<br>RCA, RCB,<br>RCD, RCE, RCF                                     | Type 087 M<br>Code letter<br>RH |
| Driving position 1        | i = 2.7143   | i = 2.5517                      |
| Driving position 2        | i = 1.5000   | i = 1.4483                      |
| Driving position D        | i = 1.0000   | i = 1.0000                      |
| Driving position R        | i = 2.4286   | i = 2.4615                      |
| Clutch                    | Hydrodynamic torque converter  |                                 |
| Converter ratio           | 2.08 (2.5)   |                                 |
| Converter code            | J (K)  |                                 |
| Stall speed               | 2200 + 200 rpm<br>(2800 ± 200 rpm)   |                                 |
| Final drive               | Hypoid/ring gear   |                                 |
| Hypoid displacement       | 44 mm  |                                 |
| Final drive ratio         | 12/37 (11/38)  |                                 |
| <u>Filling Capacities</u> |  |                                 |
| Final drive               | Approx. 1 liter hypoid gear<br>lube SAE 90 of API classifi-<br>cation GL5, or MIL - L 2105 B         |                                 |
| Automatic transmission    | Total volume with ATF coolant<br>approx. 6.5 liters of ATF<br>Dexron<br>Change volume 2.8 liters ATF |                                 |

USA - values in parentheses

### POSITION OF SHIFT PARTS IN DIFFERENT SELECTOR LEVER RANGE OR GEAR POSITIONS

When complaints are received concerning insufficient acceleration and speed values or general drive problems, this table shows which shift parts are operated in the different gears or ranges. This could point out which shift parts are malfunctioning.

Example: no power transmission in 3rd and reverse gears.

Possible cause: D + R clutch malfunctioning (must be closed).

| Gear                       | 1st Gear              | 1st Gear  | 2nd Gear              | 3rd Gear              | Reverse Gear          |
|----------------------------|-----------------------|-----------|-----------------------|-----------------------|-----------------------|
| Selector lever pos.        | "1"                   | "2" + "D" | "2" + "D"             | "D"                   | "R"                   |
| Forward clutch             | closed                | closed    | closed                | closed                | open                  |
| D + R clutch               | open                  | open      | open                  | closed                | closed                |
| 1st and reverse gear brake | applied               | released  | released              | released              | applied               |
| 2nd gear brake             | released              | released  | applied               | released              | released              |
| One-way clutch             | no power transmission | holds     | no power transmission | no power transmission | no power transmission |

## PLANETARY GEARS WITH SHIFT PARTS

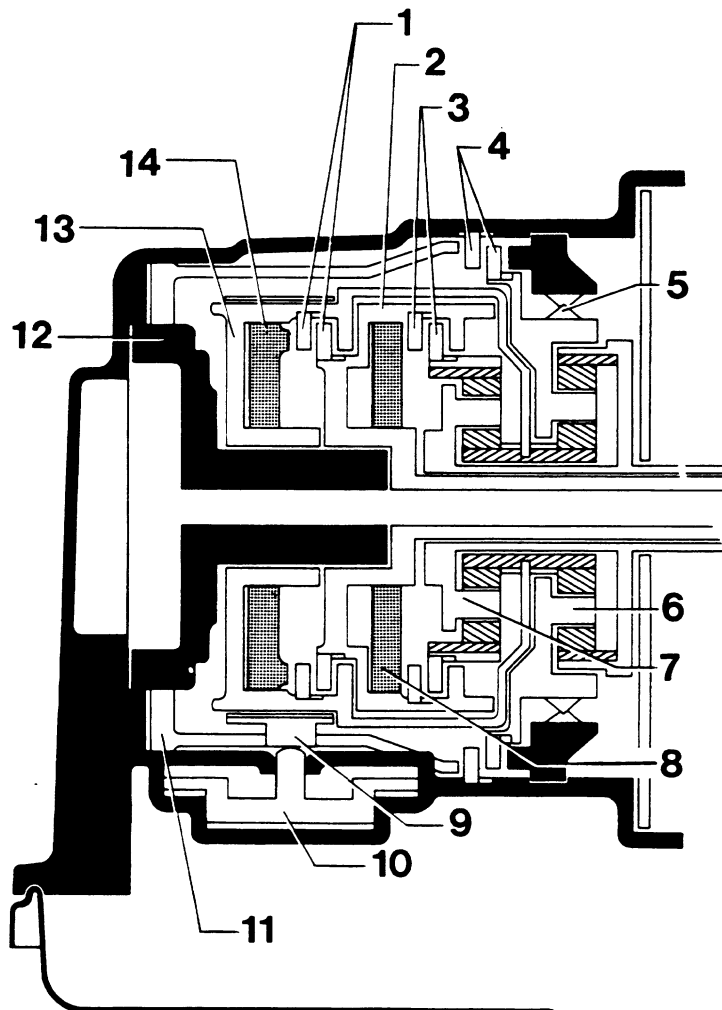

- 1 – Plates for direct and reverse gear clutch
- 2 – Forward clutch
- 3 – Plates for forward clutch
- 4 – Plates for 1st and reverse brake
- 5 – 1st gear one-way clutch
- 6 – Reverse planetary gear set
- 7 – Forward planetary gear set
- 8 – Piston for forward clutch
- 9 – 2nd gear brake band
- 10 – Piston for 2nd gear brake band (shown offset 90°)
- 11 – Piston for 1st gear and reverse gear brake
- 12 – Oil pump
- 13 – Direct and reverse gear clutch
- 14 – Piston for direct and reverse gear clutch

## TORQUE SPECIFICATIONS FOR AUTOMATIC TRANSMISSION

| Location  | Description | Threads    | Material  | Torque<br>Nm (ft lb) |
|---|-------------|------------|-----------|----------------------|
| Plug for test connection                        | Plug        | M 10 x 1   | 5.6       | 15<br>(11)           |
| ATF filler tube to oil pan                      | Coupling    | M 24 x 1.5 | 9SMn 28 K | 80<br>(58)           |
| ATF supply tank to holder                       | Bolt        | M 6        | 8.8       | 7<br>(5)             |
| ATF supply tank holder<br>to transmission       | Bolt        | M 10       | 8.8       | 42<br>(30)           |
| Automatic transmission to<br>final drive        | Nut         | M 8 x 1.25 | 12.9      | 29<br>(21)           |
| Intermediate plate to<br>transmission case      | Bolt        | M 5 x 0.8  | 5.8       | 3.5<br>(2.5)         |
| Pump to transmission case                       | Bolt        | M 6 x 1    | 8.8       | 7.0<br>(5)           |
| Cover to pump body                              | Bolt        | M 4 x 0.7  | 5.8       | 1.4<br>(1)           |
| 2nd gear brake band<br>adjustment               | Nut         | M 12 x 1.5 | 8.8       | 19.6<br>(14)         |
| Oil pan to transmission case                    | Bolt        | M 8 x 1.25 | 8.8       | 20.5<br>(15)         |
| Oil filter screen to valve<br>body              | Bolt        | M 5 x 0.8  | 5.8       | 3.5<br>(2.5)         |
| Valve body to transmission<br>case              | Bolt        | M 6 x 1    | 8.8       | 3.5<br>(2.5)         |
| End plate to valve body                         | Bolt        | M 5 x 0.8  | 5.8       | 3.5<br>(2.5)         |
| Support to transfer plate                       | Screw       | M 5 x 0.8  | 5.8       | 3.5<br>(2.5)         |
| Separation and transfer<br>plates to valve body | Screw       | M 5 x 0.8  | 8.8       | 3.5<br>(2.5)         |
| Manual valve lever to<br>transmission case      | Bolt        | M 6 x 1    | 5.8       | 3.5<br>(2.5)         |

| Location                                   | Description | Threads    | Material  | Torque<br>Nm (ft lb) |
|--|-------------|------------|-----------|----------------------|
| Shift segment to manual valve lever        | Nut         | M 16 x 1.5 | 9SMn28 K  | 20.5<br>(15)         |
| Kickdown valve lever to throttle shaft     | Nut         | M 8 x 1.25 | 9SMn28 K  | 17<br>(12)           |
| Shift segment spring to transmission case  | Bolt        | M 8 x 1.25 | 8.8       | 20.5<br>(15)         |
| Control cable lever to shaft               | Nut         | M 10 x 1   | 9SMn28 K  | 18<br>(13)           |
| Governor cover to final drive case         | Bolt        | M 8 x 1.25 | 8.8       | 9<br>(7)             |
| Governor shaft to governor housing         | Screw       | M 5 x 0.8  | 5.8       | 3.5<br>(2.5)         |
| Flanged shaft to differential              | Bolt        | M 8 x 1.25 | 8.8       | 25<br>(18)           |
| Lockplate to adjusting ring                | Bolt        | M 6 x 1    | 8.8       | 8<br>(6)             |
| Pinion cover to final drive case           | Bolt        | M 10 x 1.5 | 10.9      | 42<br>(30)           |
| Final drive case cover to final drive case | Bolt        | M 8 x 1.25 | 10.9      | 25<br>(18)           |
| Ring gear to differential                  | Bolt        | M 10 x 1   | 12.9      | 78 – 93<br>(56 – 67) |
| Oil filler opening in transmission case    | Plug        | M 24 x 1.5 | UO-St36-2 | 20<br>(14)           |
| ATF line adapter to final drive case       | Adapter     | M 16 x 1.5 | 9SMn28 K  | 80<br>(58)           |
| Converter to drive plate                   | Bolt        | M 8        | 12.9      | 40<br>(29)           |

TORQUE SPECIFICATIONS FOR ATF COOLING AND ATF SUPPLY TANK  
(AUTOMATIC TRANSMISSION )

| Location                               | Description   | Threads   | Material | Torque<br>Nm (ft lb) |
|--|---------------|-----------|----------|----------------------|
| Pipe lines to connector                | Coupling nut  | M 16      | 5.8      | 30<br>(22)           |
| Line to transmission outlet            | Hollow bolt   | M 12      | 6.8      | 22.5<br>(16)         |
| Line to transmission inlet             | Coupling nut  | M 16      | 5.8      | 30<br>(22)           |
| Line to radiator inlet                 | Hollow bolt   | M 14      | 6.8      | 22.5<br>(16)         |
| Line to radiator outlet                | Coupling nut  | M 16      | 5.8      | 30<br>(22)           |
| Lines to central tube housing          | Bolt          | M 6       | 8.8      | 5<br>(3.6)           |
| Lines to central tube                  | Clamp         | —         | —        | 3<br>(2.2)           |
| Lines to camshaft housing              | Bolt          | M 6       | 8.8      | 5<br>(3.6)           |
| Adapter to radiator                    | Adapter       | M 14      | 9SMn28K  | 30<br>(22)           |
| ATF supply tank holder to transmission | Bolt          | M 10 x 22 | 8.8      | 42<br>(30)           |
| ATF supply tank to holder              | Bolt          | M 6 x 15  | 8.8      | 7<br>(5)             |
| ATF filler tube to oil pan             | Coupling bolt | M 24      | 9SMn28K  | 80<br>(58)           |

## TIGHTENING TORQUE FOR SHIFT CONTROLS (AUTOMATIC TRANSMISSION)

| Location                           | Description  | Threads | Material  | Torque Value<br>Nm (ft lb) |
|------------------------------------|--------------|---------|-----------|----------------------------|
| Selector lever guide to shift base | Nut          | M 6     | 8         | 9<br>(7)                   |
| Locking element to shift base      | Bolt         | M 6     | 8.8       | 8.2<br>(6)                 |
| Shift mechanism and guide strip    | Bolt         | M 6     | 8.8       | 8.2<br>(6)                 |
| Bracket to transmission            | Bolt         | M 8     | 8.8       | 21<br>(15)                 |
| Cable to console                   | Coupling nut | M 8     | 9SMn 28 K | 8<br>(6)                   |
| Cable to bracket                   | Coupling nut | M 8     | 9SMn 28 K | 8<br>(6)                   |
| Ball socket to cable               | Nut          | M 5     | 8         | 5<br>(3.6)                 |



## TIGHTENING TORQUE FOR THROTTLE CONTROLS (AUTOMATIC TRANSMISSION)

| Location  | Description | Threads | Material | Torque Value<br>Nm (ft lb) |
|---|-------------|---------|----------|----------------------------|
| Control cable to bracket<br>(engine)                                | Nut         | M 8     | 04       | 5<br>(3.6)                 |
| Control cable to trans-<br>mission                                  | Nut         | M 10    | 17H - 2  | 20<br>(15)                 |
| Control cable to central<br>tube                                    | Hose clamp  | M 4     | —        | 3<br>(2.2)                 |
| Bonded rubber mount<br>to intermediate lever<br>(accelerator pedal) | Lock nut    | M 6     | 6        | 9<br>(7)                   |
| Accelerator pedal to<br>floor plate                                 | Nut         | M 6     | 8        | 5<br>(3.6)                 |

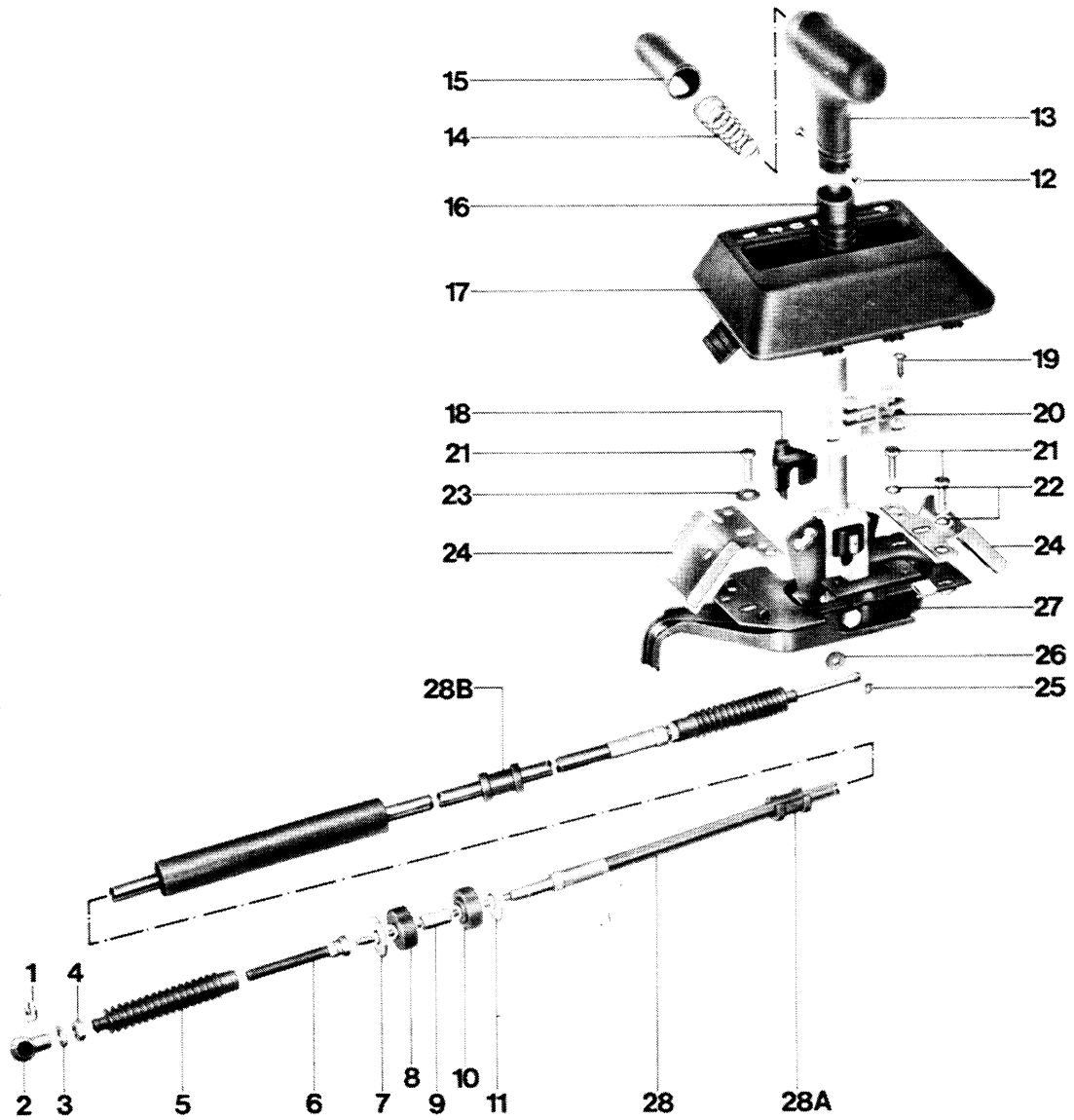

| No. | Description   | Qty. | Note When: |  | Special Instructions |
|-----|---------------|------|------------|--|----------------------|
|     |               |      | Removing   | Installing                                       |                      |
| 1   | Lockplate     | 1    |            |  |                      |
| 2   | Ball socket   | 1    |            | Do not mix up with ball socket for control cable |                      |
| 3   | Washer        | 1    |            |  |                      |
| 4   | Nut           | 1    |            |  |                      |
| 5   | Dust cover    | 1    |            |  |                      |
| 6   | Mounting tube | 1    |            | Torque:<br>8 Nm (6 ft lb)                        |                      |
| 7   | Washer        | 1    |            |  |                      |
| 8   | Rubber washer | 1    |            | Stepped end faces bracket                        |                      |
| 9   | Sleeve        | 1    |            |  |                      |
| 10  | Rubber washer | 1    |            | Stepped end faces bracket                        |                      |
| 11  | Washer        | 1    |            |  |                      |
| 12  | Bolt          | 2    |            |  |                      |
| 13  | Selector grip | 1    |            |  |                      |
| 14  | Spring        | 1    |            |  |                      |
| 15  | Push button   | 1    |            |  |                      |
| 16  | Sleeve        | 1    |            |  |                      |
| 17  | Cover         | 1    |            | Squeeze retaining tabs on sides and remove       |                      |
| 18  | Bulb holder   | 1    |            |  |                      |
| 19  | Screw         | 2    |            |  |                      |

| No. | Description          | Qty. | Note When:   |   | Special Instructions |
|-----|----------------------|------|--------------|---|----------------------|
|     |                      |      | Removing     | Installing  |                      |
| 20  | Contact plate        | 1    |              | Installation mark must align with contact. Engine must start only in position "N" or "P". Coat contact surface with Molykote paste. |                      |
| 21  | Bolt                 | 3    |              | Torque:<br>8.2 Nm (6 ft lb)   |                      |
| 22  | Small washer         | 2    |              |   |                      |
| 23  | Large washer         | 1    |              |   |                      |
| 24  | Strip guide          | 2    |              |   |                      |
| 25  | Lock washer          | 1    |              |   |                      |
| 26  | Rubber washer        | 1    |              |   |                      |
| 27  | Shift mechanism      | 1    |              |   |                      |
| 28  | Selector lever cable | 1    | Do not bend. | Do not bend. Adjust.  |                      |

## REMOVING AND INSTALLING SELECTOR LEVER CABLE

## Removing

1. Unscrew battery ground strap.
2. Remove exhaust assembly and center shield.
3. Disconnect cable on transmission lever and bracket. Remove mounting parts.
4. Bend open cable clip on center tunnel with a suitable tool (e. g. tire iron).
5. Remove selector lever knob, pull cover out of center console and remove sleeve.
6. Remove light for illuminated dial and contact plate.
7. Mark location of shift control on center tunnel for reinstallation.
8. Unscrew bolts and remove guide plates.

## Note :

Cable is locked on ball socket with a lockpin to prevent jumping out.

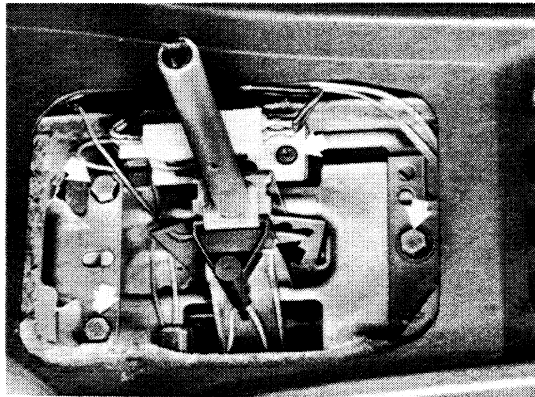
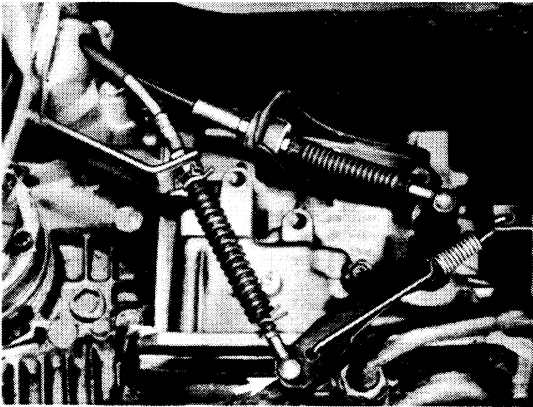

4. Bend open cable clip on center tunnel with a suitable tool (e. g. tire iron).

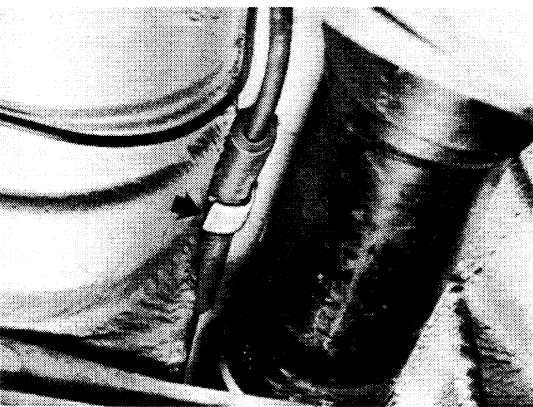

9. Lift shift control forward slightly and only pull out forward far enough so that selector lever cable can be disconnected on shift base and selector lever.
10. Mount wire on cable and pull cable toward rear through insulation sheet carefully.

### Installing

1. Slide rubber grommet (see position 28 B in layout drawing) on to cable sleeve and coat front dust cover with an assembly paste (e. g. rubber lubricant).
2. Mount wire, pulled back during removal, on cable and pull cable forward through insulation sheet carefully.

### Note :

For this job one person in the passenger compartment should pull the wire and a second person should guide it through the insulation sheet from underneath.

3. Mount cable on shift control and install shift base. Tightening torque for cable sleeve to shift control: 8 Nm (6 ft lb).

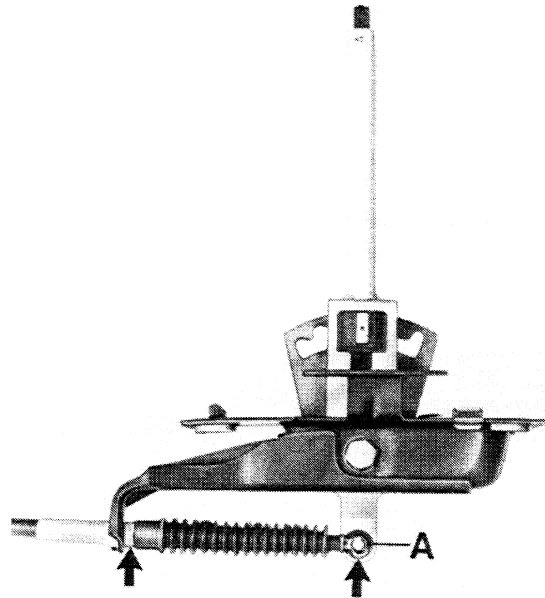

A — Rubber washer

4. Install contact carrier so that the installation mark is aligned with the contact.

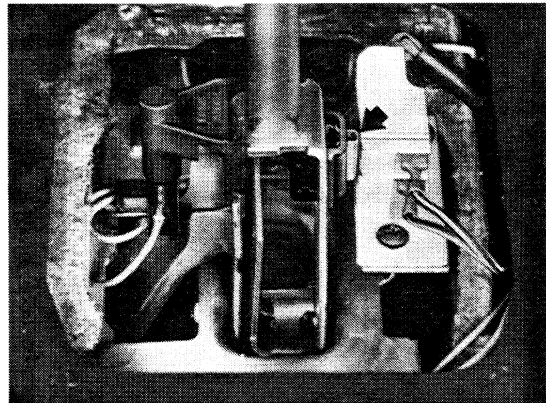

5. Push cable through opening in suspension console and mount on bracket as well as transmission lever.

Note:

Use a rubber grommet in opening of suspension console to reduce the noise level.

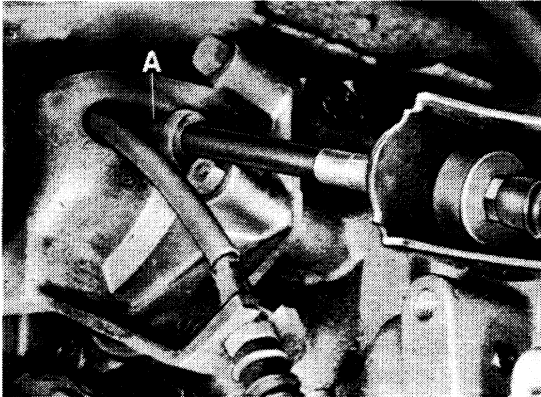

A – Rubber grommet (position 28 A)

6. Mount cable sleeve on center tunnel with a clamp.

7. Adjust rubber grommet (position 28 B in layout drawing) so that cable sleeve cannot contact center tunnel.

8. Adjust cable (see page 37 - 7).

## ADJUSTING SELECTOR LEVER CABLE

1. Place selector lever in "P".
2. Place operating lever on transmission in "P" (push back against stop).
3. Adjust ball socket on cable so that installation without tension is possible.

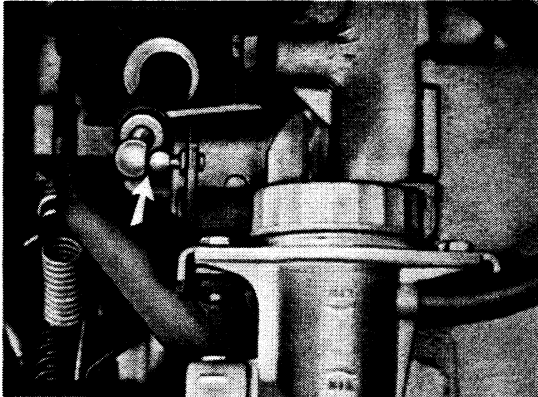

3. Repeat test in point 1.
4. Place selector lever in "N". Interruption of power transmission should be indicated by rise in engine speed.
5. Place selector lever in "D". Power transmission should be indicated by drop in engine speed.
6. It should only be possible to start engine in "P" and "N".
7. Backup lights must be on in "R".

## Note :

Use lockpin to prevent ball socket from popping out.

## Checking Adjustment

Place selector lever in "N". Run engine at fast idle speed.

Pull up parking brake lever and brake car with brake pedal for following tests.

1. Place selector lever in "R". Power transmission must be indicated by drop in engine speed.
2. Place selector lever in "P". Reverse gear disengages as indicated by rise in engine speed.



## REMOVING AND INSTALLING THROTTLE AND CONTROL PRESSURE CABLE

1. Disconnect cable on accelerator pedal intermediate lever (is only inserted).
2. Disconnect cable sleeves on bracket.
3. Press rubber guide out of firewall with a suitable screwdriver.
4. Open clamps for cable sleeve on engine and front bell housing.
5. Remove exhaust assembly as well as front and center cross members.
6. Remove front bracket for exhaust assembly on holder.
7. Disconnect ball socket on transmission lever and disconnect cable sleeve on bracket.
8. Mark location of hose clamp and cable sleeve for installation later and remove clamp.

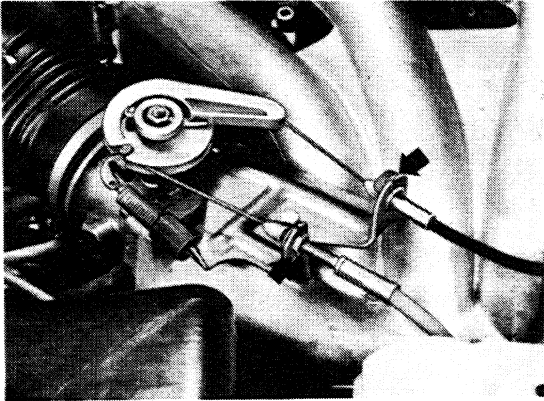

## Note :

A lockpin prevents the ball socket from popping out.

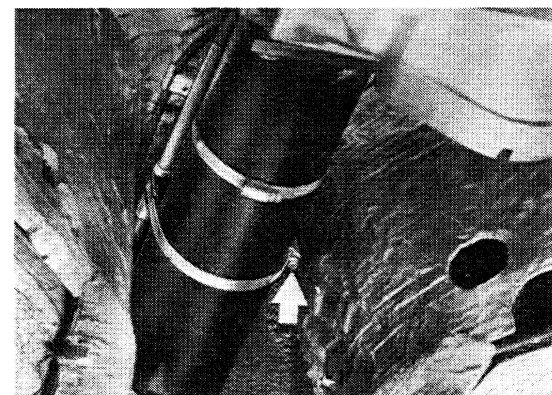
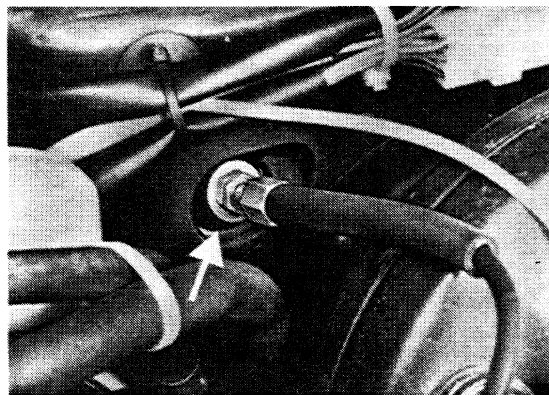
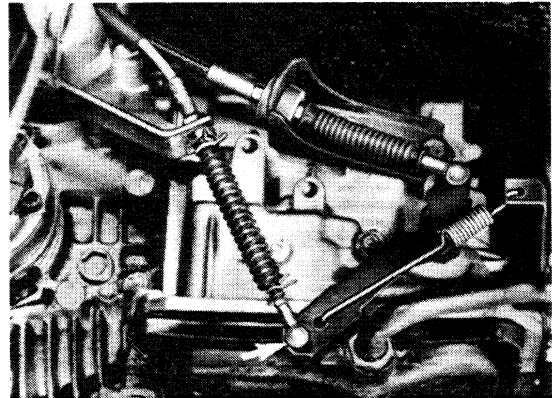

4. Open clamps for cable sleeve on engine and front bell housing.
5. Remove exhaust assembly as well as front and center cross members.

9. Press cable sleeve out of hose holder.

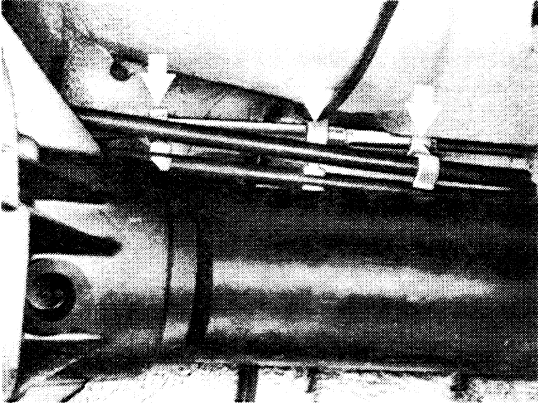

1. Push in cable in correct position toward rear to transmission lever and forward to cam plate.

2. Coat cable in area of insulation sheet with an assembly paste (e. g. rubber lubricant) and pull cable carefully to correct installed position between insulation sheet and body. Press insulation sheet away from body with a suitable putty knife for this step.

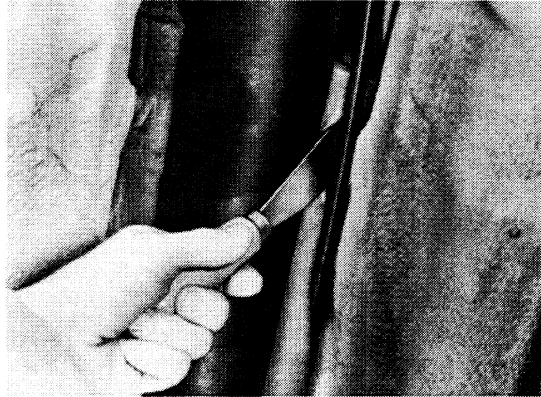

10. Pull out cable downward carefully (between insulation sheet and body) with a wire hook.

Note :

Press insulation sheet away from body with a putty knife to avoid damaging sheet.

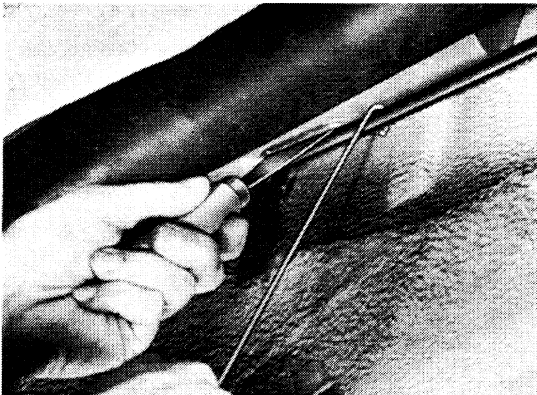

3. Align cable sleeve according to removal marks and tighten hose clamp.

4. Press cable sleeve into holder.

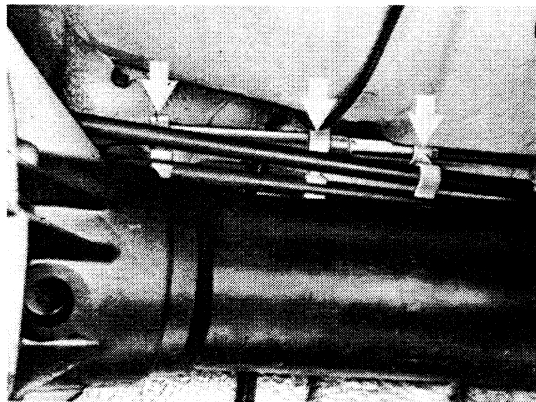

Installing

Note :

Cable must not be bent excessively.

5. Mount cable correctly on transmission, cam plate and accelerator pedal intermediate lever.

6. Adjust cable (see page 37 - 11).

## REMOVING AND INSTALLING THROTTLE AND CONTROL PRESSURE CABLE (SERVICE SOLUTION)

### Removing

1. Disconnect cable on transmission lever and unscrew ball socket.

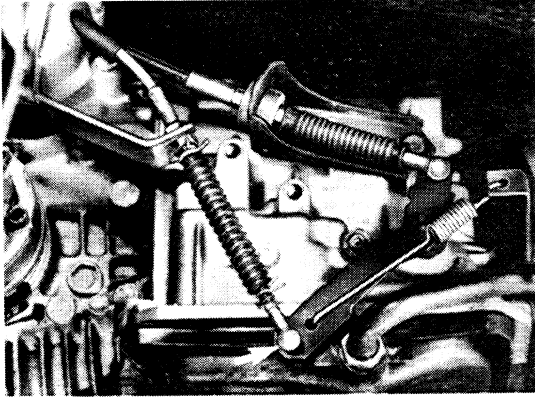

### Note :

A lockpin prevents ball socket from popping out.

2. Disconnect control cable on accelerator pedal and press rubber guide out of firewall.

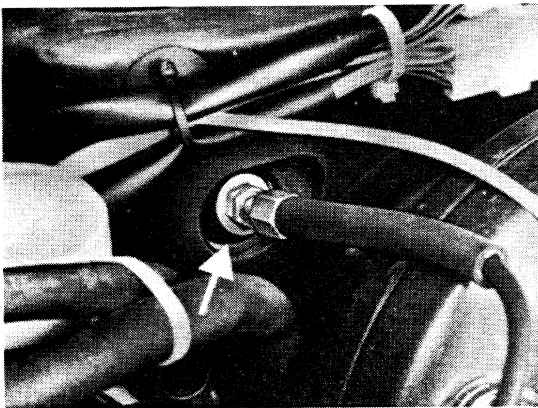

3. Disconnect short cable sleeve on holder.

4. Pinch and pull out control cable toward rear.

### Installing

1. Assemble cable by sliding short cable sleeve, clamping nipple and protective cap on to cable.



2. Push cable through sleeve from behind carefully and place around cam plate correctly (nipple in opening).

3. Mount cable sleeve on holder and firewall.

4. Mount cable on accelerator pedal.

5. Install dust cover and clamp.

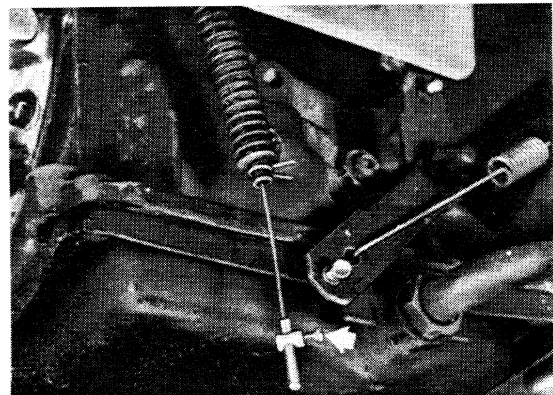

6. Connect ball socket on transmission lever without tension.
7. Mount clamping nipple and check both full throttle and kickdown positions (see page 37 - 12).

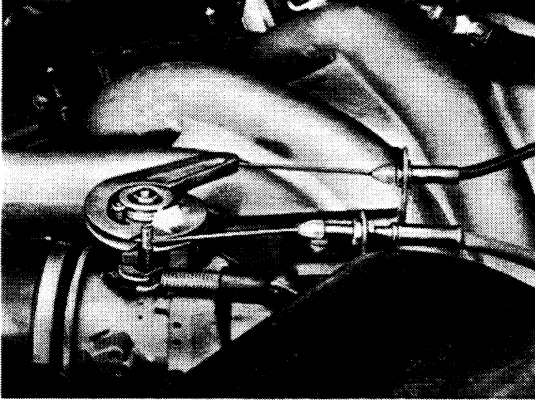

8. If necessary, adjust cable (see page 37 - 11).

## ADJUSTING THROTTLE AND CONTROL PRESSURE CABLE

### Note

The positioning of the throttle to the valves in the transmission is extremely important for perfect transmission operation and unimpaired driving of car.

### Basic Setting

1. Install cable sleeve on transmission bracket at distance "A" = 29 mm and tighten to torque of 20 Nm.

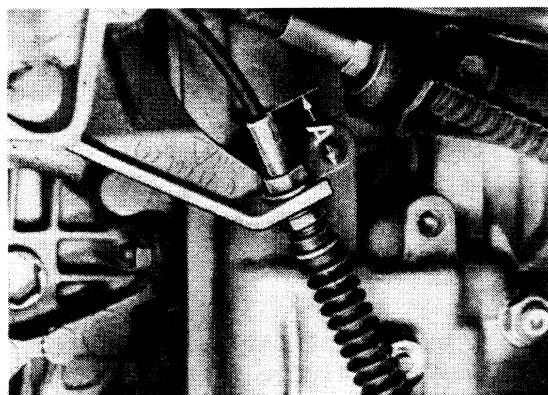

2. Screw on plastic socket for transmission lever completely and secure on transmission lever with securing clip.

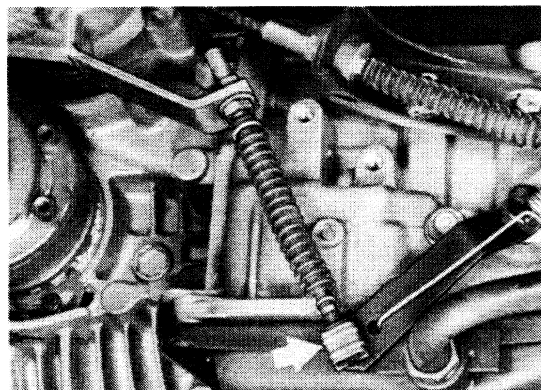

3. Set accelerator pedal and cam to neutral position
4. Make sure short cable sleeve fits correctly in firewall.

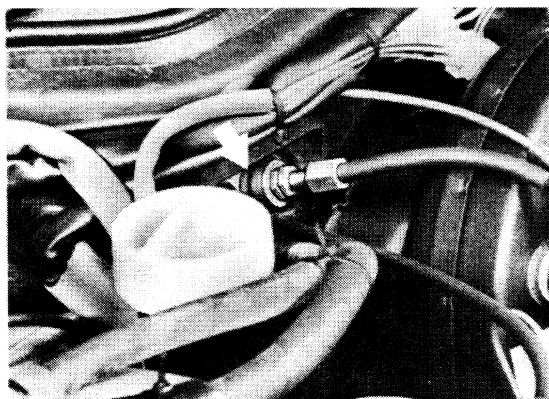

Up to Mod. '85

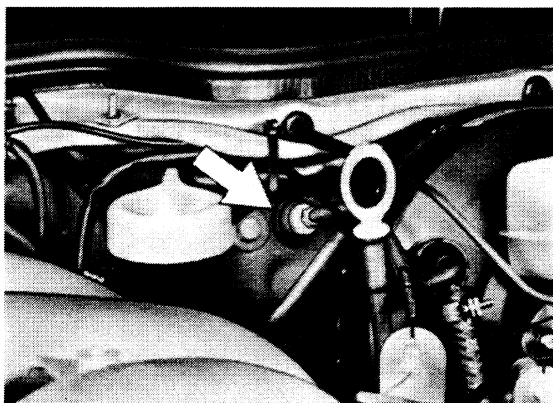

From Mod. '85/2, adjust short cable sleeve on holder to shortest length.

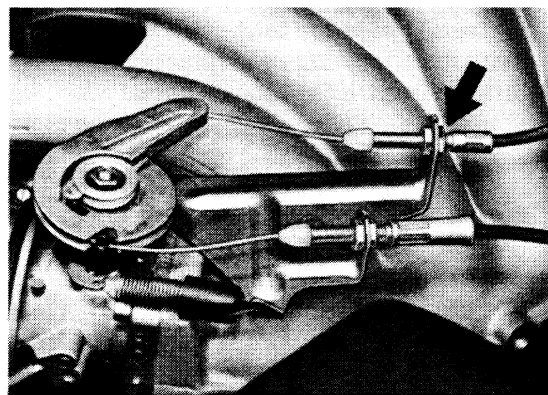

From Mod. '85/2

5. Up to Mod. '85 adjust short cable sleeve on firewall to dimension "B" = 8 mm

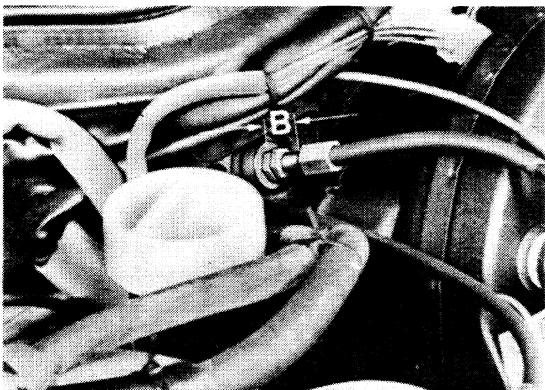

6. Place cable around cam plate in correct position and secure short cable sleeve on holder with circlip. From Mod. 85/2, cable sleeve screwed onto holder.
7. Install long cable sleeve on holder without tension (don't pull tight).
8. Adjust short cable sleeve until clamping nipple of cable can be placed in opening of cam plate without tension.  
Tighten nut for cable sleeve adjustment to torque of 5 Nm.

#### Note

It is very essential that the control pressure (accelerator side) cable be without tension, since the throttle switch (idle contact) will already be operated in a 1° throttle range.

9. Adjust long cable sleeve on holder in the area of the cam until a prestress of 2...3 mm is achieved on control pressure cable.
10. If cable has been adjusted correctly, cam and accelerator pedal will be in neutral position and transmission operating lever will be in prestress position (2).

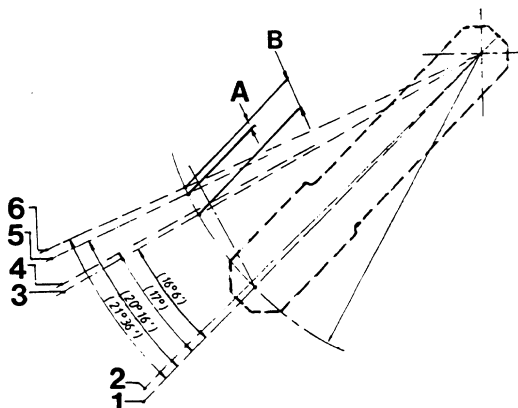

- 1 = Basic position
- 2 = Prestress position
- 3 = Full throttle position
- 4 = Kickdown start
- 5 = Kickdown end
- 6 = Final stop
- A = 0...2.5 mm
- B = 10 mm

### Full Throttle Test

Press down on accelerator pedal to first noticeable pressure point (full throttle point) and check, whether throttle is wide open.

In this position, the dog in the cam plate's slot will not yet have lifted off.

Operating lever on transmission will be 10 mm away from final stop (dimension "B").

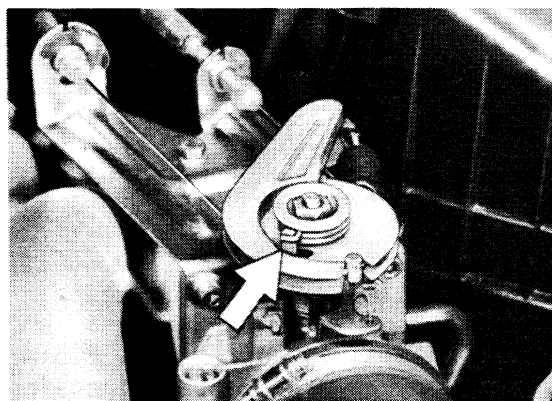

### Kickdown Test

1. Depress accelerator pedal past full throttle up to kickdown point. In this position, check whether dog in cam plate's slot has lifted (against stop).

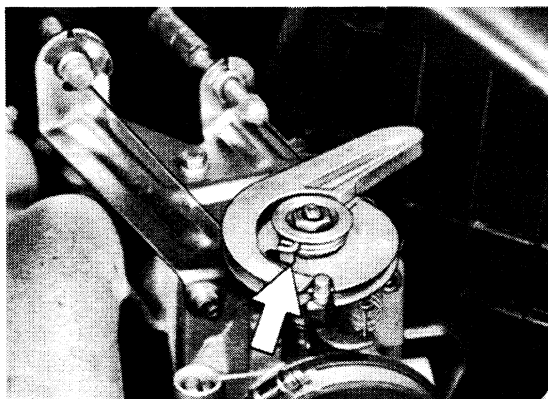

2. Adjust stop bolt for accelerator pedal in this position (kickdown) so that bolt touches the accelerator pedal. Then unscrew bolt one half turn.

Note

If lever is more than 2.5 mm away from final stop, the long cable sleeve on the holder must be readjusted in the area of the cam plate.

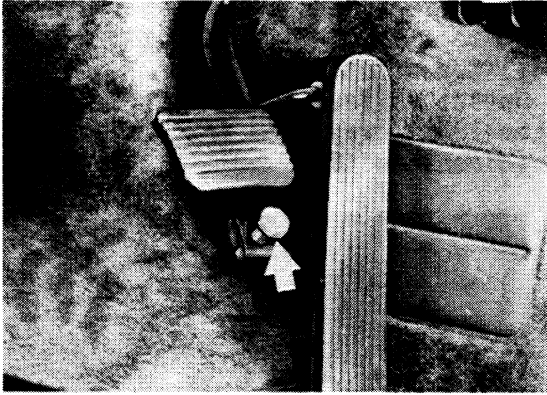

3. In kickdown position, the operator lever on the transmission must be 0...2.5 mm away from final stop (dimension "A").

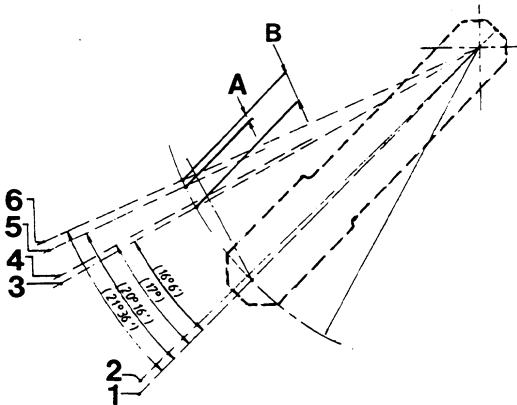



## Checking Function

The cause of damage or defect can be pinpointed with help of the troubleshooting card (page 37-17) and the following tests before repairing an automatic transmission.

- A – General Test
- B – Automatic Transmission and Final Drive Oil Level Test
- C – Stall Speed Test
- D – Road Test
- E – Pressure Test

### Important!

All jobs, which require the engine to be running, should only be performed with the selector lever in "N" or "P" and the parking brake applied.

Exceptions: tests, which require a different selector lever position briefly.

### A – General Test

The following procedures must be carried out prior to each transmission test and, if any faults are discovered, they must be eliminated before continuing work on the transmission.

1. Check engine tuning (ignition timing, idle speed and transition).
2. Check for external damage, e. g. leaks on transmission (ATF) or final drive (hypoid oil) and missing or loose mounting bolts.

### B – Automatic Transmission and Final Drive Oil Level Test

The specified oil level is extremely important for perfect operation of an automatic transmission, and therefore it is important to carry out the following test conscientiously.

## Checking ATF Level in Automatic Transmission

1. Car must be parked on level floor or ground.
2. Selector lever in "N" and parking brake applied.
3. Engine running at idle speed during test.
4. ATF hand warm (40 to 60 °C/104 – 140 °F).
5. ATF level between both marks of supply tank. Difference between upper and lower marks is approx. 0.4 liter/US qt.
6. Clean upper section of tank as well as cover prior to filling with ATF to avoid dirt in the supply tank.

### Important!

Oil level can be higher or lower depending on temperature (heat expansion of ATF). Consequently an accurate check can only be made in the specified temperature range.

Do not add too much ATF, since an excessive amount would impair automatic transmission operation.

Contaminated oil could impair transmission control.

### Important!

Only fill automatic transmission with ATF Dexron.

ATFs of different makes with the designation "Dexron" may be mixed with each other.

### Checking Final Drive Oil Level

1. Oil level should reach edge of oil filler plug. An excessively high oil level indicates an oil leak between the automatic transmission and final drive.

In this case the governor drive seal could be defective.

Engine speed faster than stall speed:

Forward clutch slips.  
1st gear one-way clutch slips.

Stall speed not reached:

– about 200 rpm less than specified value

Poor engine power (ignition, fuel injection, compression)

– about 400 rpm less than specified value

One-way clutch in torque converter defective

### C – Stall Speed Test

This test provides information on operation of the torque converter, plate clutches and brakes as well as one-way clutch for 1st gear.

Note:

Stall speed will be reduced by about 125 rpm for each 1,000 meters (3,300 ft) above sea level.

#### Important!

The stall speed could also drop slightly with high outside temperatures.

The stall speed test must be carried out with the engine and transmission at operating temperature and must not last longer than the time required to read the tachometer (max. 5 seconds) to avoid damage from excessive heat.

1. Connect tachometer on engine. Start engine and hold car by applying service and parking brakes. Move selector lever to "D" and press down briefly on accelerator pedal to full throttle. The engine will adjust to a certain speed, the so-called stall speed.

Stall Speed:

2800 ± 200 rpm

The following points could be causing deviations in stall speed.

## D - R o a d t e s t

Road test car (only when there is no obvious transmission damage). It is important to drive the car in as many driving conditions as possible, and in all the driving ranges of the automatic transmission. Careful observation is a must. Pay particular attention to shifting points for upshifts and downshifts, as well as the kickdown shift points with reference to speed and gear transitions.

All shifts must be made quickly and without interruption of power flow. Particular attention should be paid to whether the engine races suddenly while shifting. This could indicate a slipping brake or clutch.

After the road test, check transmission for leakage.

## S h i f t p o i n t s i n K M / H 9 4 4 / 9 2 4 S

| Transmission Version | Shifts | Full Throttle* | Kickdown* |
|----------------------|--------|----------------|-----------|
| Transmission type    | 1 - 2  | 40 - 56        | 89 - 92   |
| 087 M                | 2 - 3  | 96 - 120       | 155 - 156 |
| Code letter          | 3 - 2  | 68 - 94        | 148 - 150 |
| RH                   | 2 - 1  | 28 - 31        | 81 - 83   |

| Transmission Version | Shifts | Full Throttle* | Kickdown* |
|----------------------|--------|----------------|-----------|
| Transmission type    | 1 - 2  | 40 - 55        | 83 - 88   |
| 087 M                | 2 - 3  | 96 - 120       | 149 - 152 |
| Code letter          | 3 - 2  | 69 - 95        | 142 - 146 |
| RCA,RCD,RCE          | 2 - 1  | 28 - 32        | 76 - 81   |

| Transmission Version | Shifts | Full Throttle* | Kickdown* |
|----------------------|--------|----------------|-----------|
| Transmission type    | 1 - 2  | 35 - 48        | 73 - 77   |
| 087 N                | 2 - 3  | 84 - 105       | 130 - 133 |
| Code letter          | 3 - 2  | 60 - 83        | 124 - 128 |
| RCB,RCF              | 2 - 1  | 25 - 28        | 67 - 71   |

\*Note that during testing the speedometer can deviate from the specified values within permissible tolerances.

## Function Test (Type 087 M and 087 N)

### E - Pressure Test

Pressure test will supply information about disturbances in the hydraulic control system.

It should only be carried out, if all other tests have not produced any indication of possible causes for the damage.

### Remarks

It is always necessary to loosen the control cable to test the main pressure. This means maladjusting the cable sleeve on the mount in the area of the cam plate. Preload must be readjusted after finishing the pressure test (see page 37 - 11).

1. Connect pressure tester V 90 on the test connection.

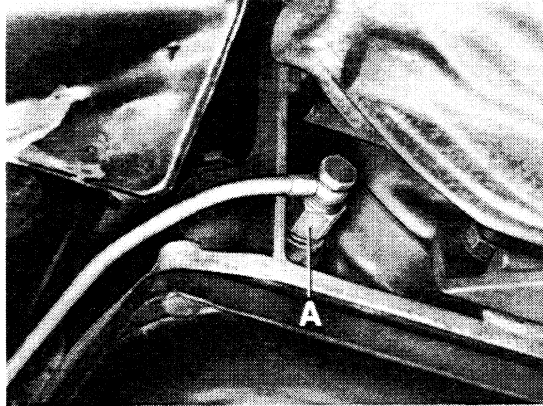

A = Special Tool 9250

2. Check main pressure with different testing conditions as described below.

944 Europe / Rest of World and USA/Japan

| Selector Lever Position | Accelerator Pedal Position | Main Pressure in bar | Testing Conditions              |
|-------------------------|----------------------------|----------------------|---------------------------------|
| D                       | Idle<br>(no acceleration)  | 2.90...3.00          | Road speed faster than 50 km/h* |
| D                       | Full throttle              | 7.3...7.40           |                                 |
| R                       | Idle (no acceleration)     | 9.5 ± 0.3            | Car stopped                     |
| R                       | Full throttle              | more than 20         | At stall speed                  |

\* Road speed faster than 140 km/h for Europe models (transmissions RCD and RCE) since December, 1983.

This test should be performed on a dynamometer whenever possible. For the pressure test in idle, accelerate the car to specified road speed, take foot off of the accelerator pedal and read the pressure.

It is not possible to adjust the main pressure. There could be the following causes for deviation from the specified values.

| Cause   | Correction  |
|---|---|
| Oil pump faulty   | Check oil pump for wear, replace.   |
| Oil loss on gasket/ sealing surfaces or due to leak in body | Check for leaks, in particular installation of valve body transfer plate. |
| Seized control valve  | Disassemble and clean valve body. Check movement of control valve.        |





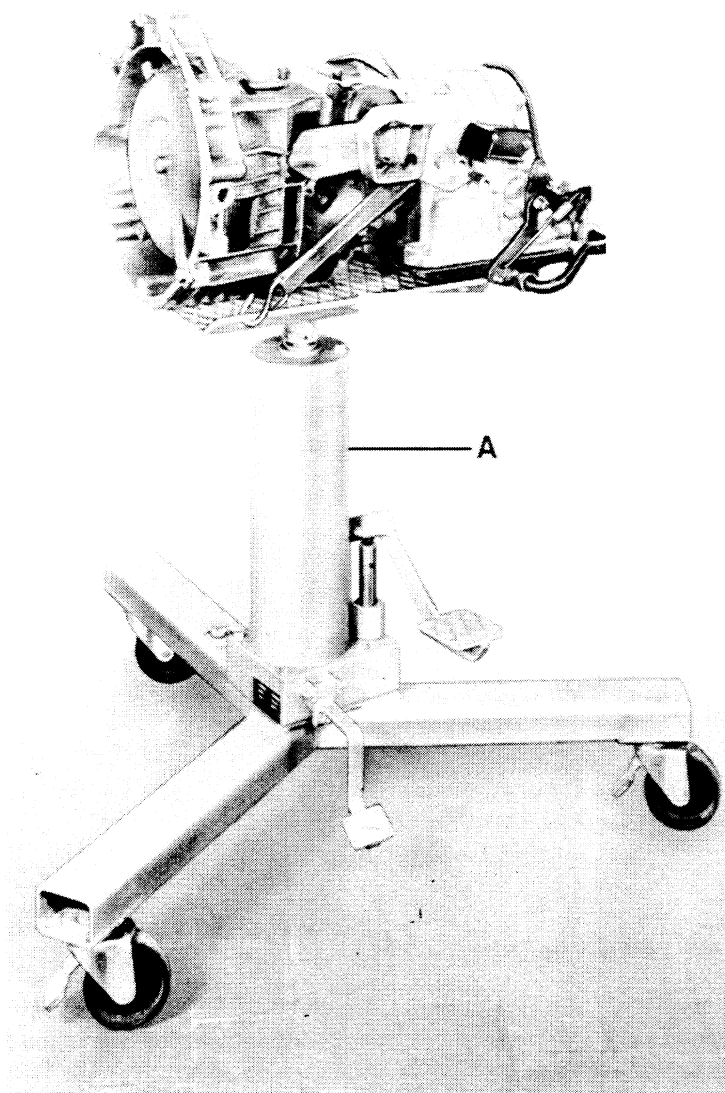

A = Universal transmission jack



## REMOVING AND INSTALLING TRANSMISSION

## Removing

1. Remove final muffler.
2. Disconnect drive shafts on transmission end and take off of flanges.

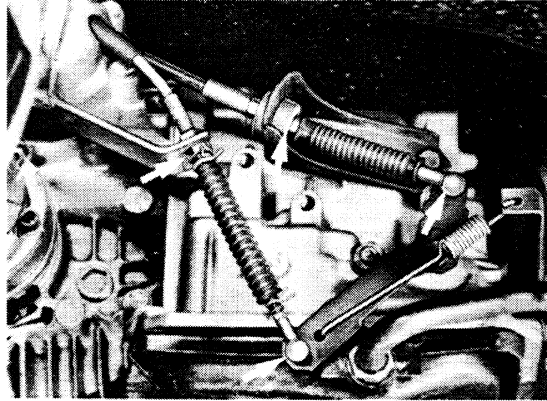
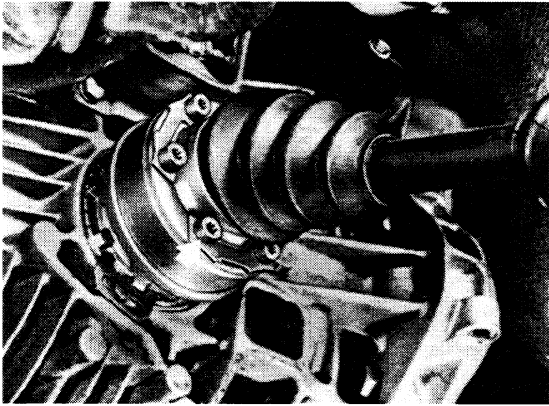

## Note :

Cables are locked in ball sockets to prevent popping out.

## Note :

Suspend drive shafts from car with pieces of wire in horizontal position to prevent damaging dust covers.

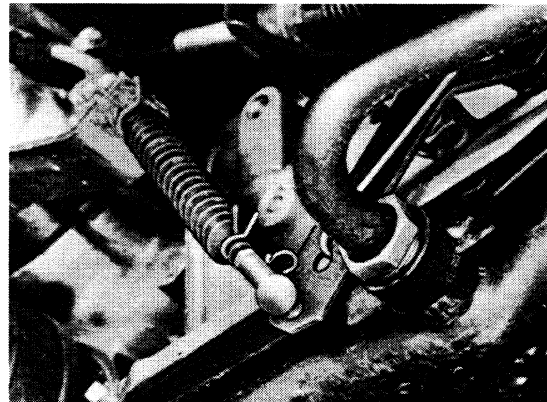

3. Detach support on rear transmission cover.

4. Disconnect selector lever cable and control pressure cable on levers and brackets.  
Pull cables forward out of suspension console.

5. Open inspection hole in rear bell housing and unscrew mounting bolts for torque converter (hold pulley if necessary).

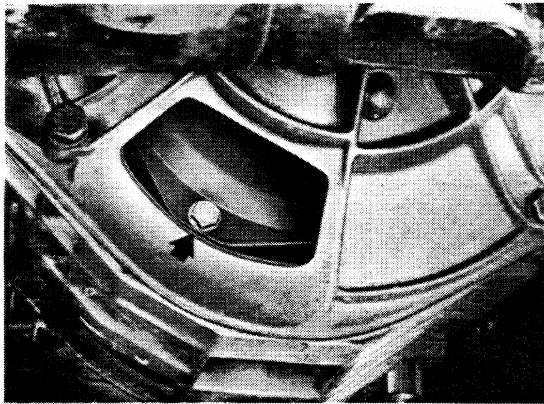

6. Place universal transmission jack underneath transmission and secure retaining strap.
7. Unscrew transmission suspension/transmission member mounting bolts.

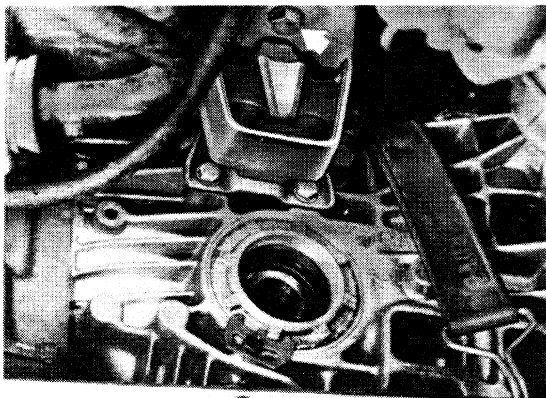

8. Remove right flange shaft and right transmission suspension.

9. Unscrew ATF lines on transmission case. Use an angled open-end wrench (e. g. Hazet 329 - 5) for coupling nut on transmission inlet.

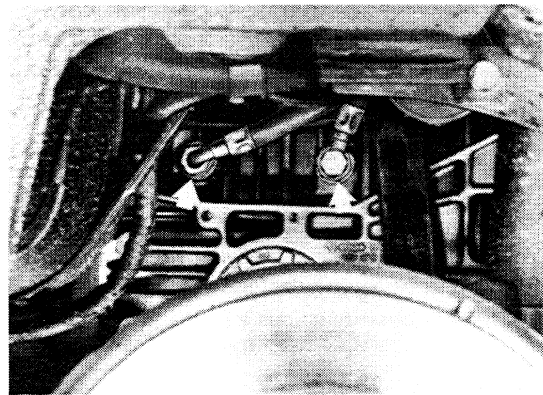

10. Unscrew transmission case/transmission bell housing mounting bolts.

11. Lower transmission slightly and run back far enough so that torque converter can be secured to prevent falling out.

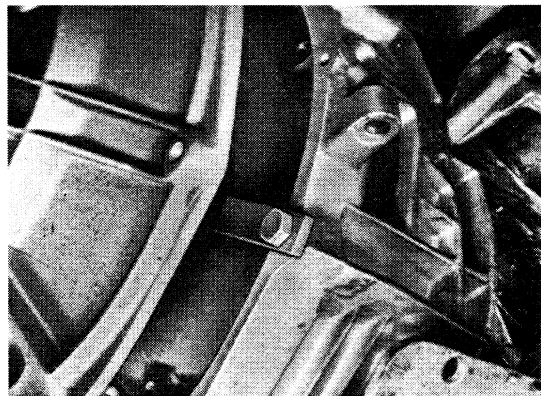

12. Lower transmission carefully on universal transmission jack.

### Correct Torque Converter Installation

Converter is inserted against stop.  
a = approx. 10 mm.

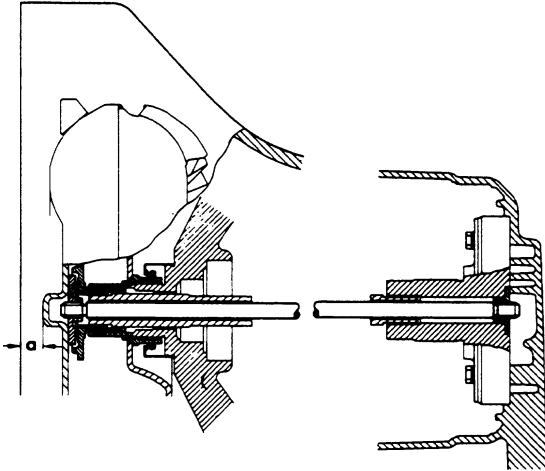

### Wrong Torque Converter Installation

Converter has slipped forward (left arrow) and has pulled pump shaft out of drive dog/pump shaft splines A (right arrow).  
Bolting the transmission on the central tube in this position would destroy the drive dog.

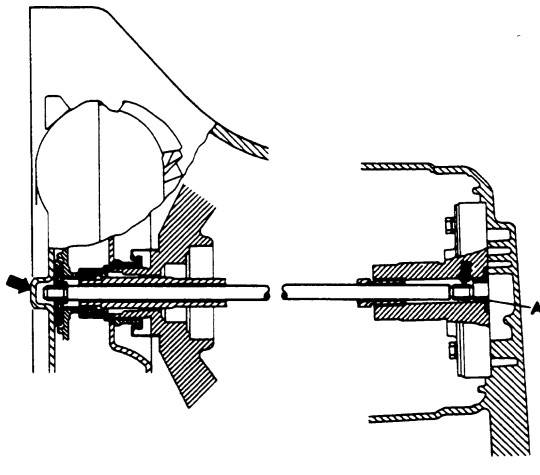

## TOOLS

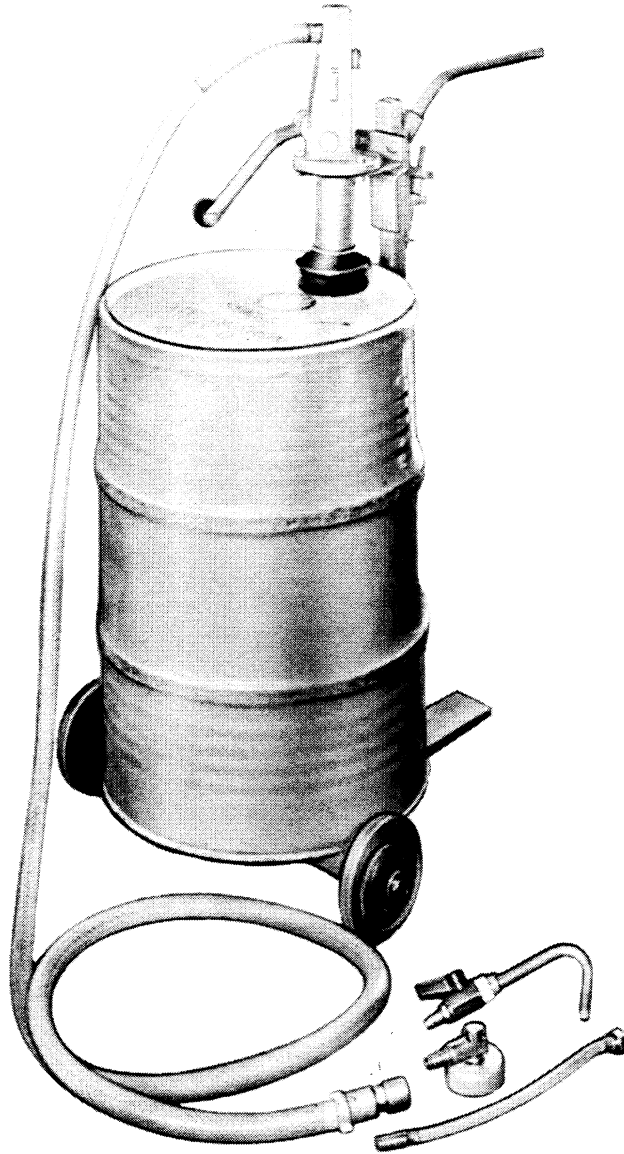

| No. | Description | Special Tool | Remarks  |
|-----|-------------|--------------|--|
|     | Filler      |              | Commercial item,<br>e. g. Dresser-Wayne Model 3009 |

## CHANGING ATF AND CLEANING ATF FILTER SCREEN

Note

ATF liquid (ATF-Dexron II D) is no longer red and transparent, but brown and becomes completely black after short operation.

Oil volume:  
New filling with ATF cooler =  
approx. 6.5 liters  
Oil change:  
approx. 2.8 liters

Oil grade:  
ATF-Dexron II D

Tightening torques:

Oil filler tube to oil sump =  
80 Nm

Oil sump to transmission case =  
21 Nm

Oil filter screen to valve body =  
4 Nm

Car must be parked on level surface and transmission should have operating temperature when changing ATF.

1. Unscrew oil filler tube at oil sump and filling tank, and drain ATF.

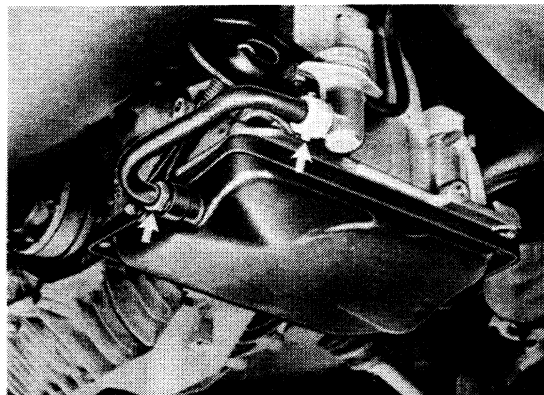

2. Remove oil sump and oil filter screen when ATF stops running out of transmission

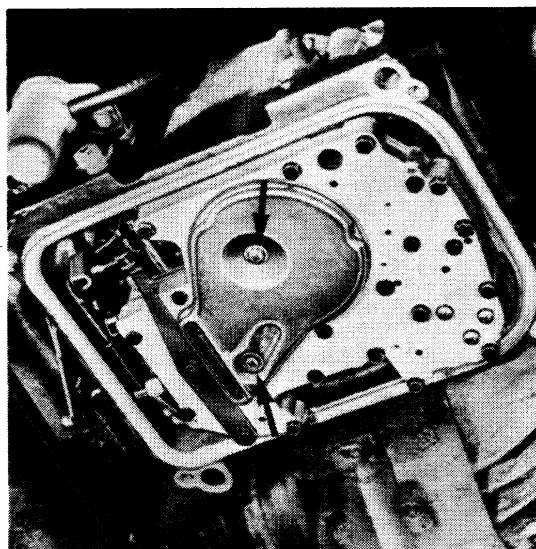

3. Clean all parts thoroughly and reinstall.  
Replace gasket for oil filter screen and oil sump.

4. Add ATF with filler.

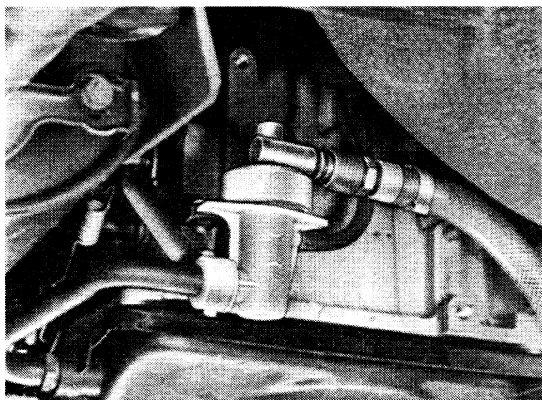

5. First add approx. 2.5 liters of ATF.

**Note :**

Clean upper section of tank and cover prior to adding ATF, to prevent dirt from entering filling tank.

6. Start engine and move selector lever through all positions on stationary car.
7. Check ATF level and, if necessary, fill to lower mark.
8. Test drive car briefly to warm up ATF hand warm.

9. Then check and correct ATF level as described below.

**Checking ATF Level**

**Note :**

The specified ATF level is extremely important for perfect operation of the automatic transmission.

1. Car must be on level surface.
2. Move selector lever to N and apply parking brake.
3. Run engine at idle speed during check.
4. ATF must be hand warm (approx. 40 to 60 °C). Heat expansion will cause deviation in ATF level at higher or lower temperatures.

5. Difference between upper and lower marks is 0.4 liters.
6. Don't add too much ATF!  
Excessive ATF would also cause disturbances and must be drained again.

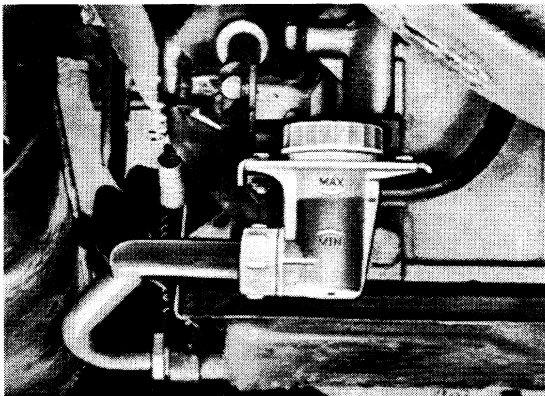

---

FLUSHING ATF COOLER AND LINES

Note :

If ATF smells burnt and contains friction liner abrasion, the transmission has to be repaired, the torque converter drained and the cooler flushed.  
The torque converter has to be replaced, if there are metal burrs in the ATF sump.

Note :

A sealing surface must be made on the adapter subsequently. Open standard bore to 10 mm diameter and drill approx. 5 mm deep. Then counterbore sealing surface with a 90° countersink.

Mount auxiliary hose from ATF filler (see Special Tool Catalog, Workshop Equipment Group) and adapter, Part No. 087.409.057 B, on return line and flush cooler with ATF. Catch ATF running out of feed line.

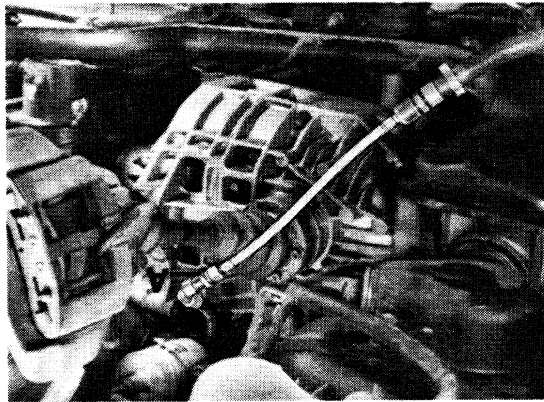

A = Adapter

Part No. 087.409.057 B



## TOOLS

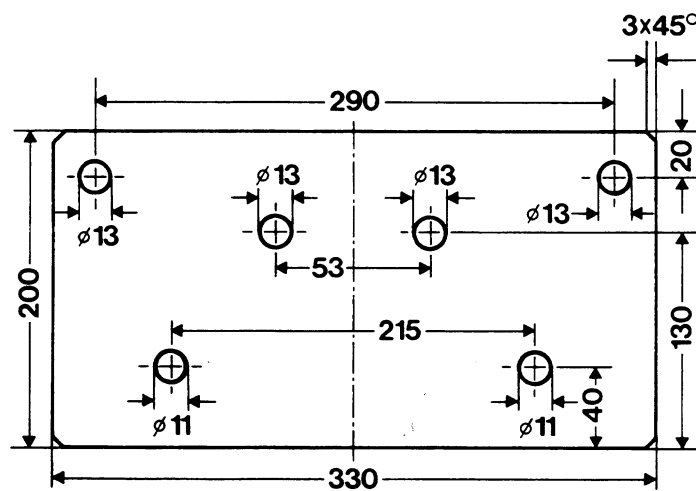
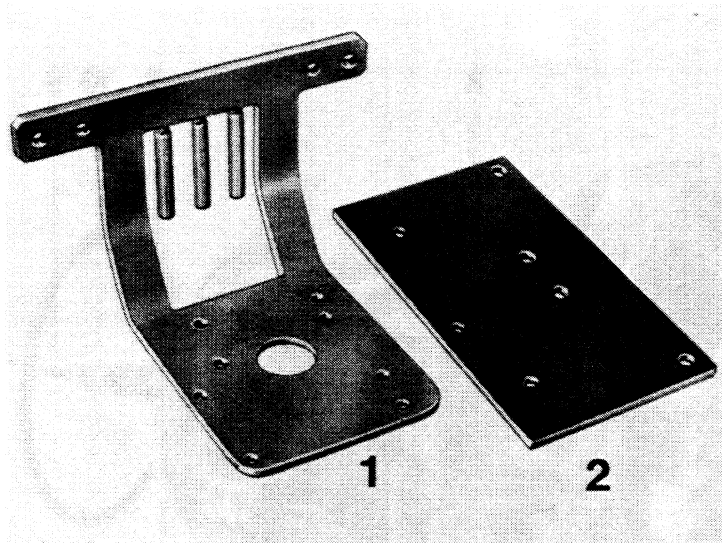

| No. | Description | Special Tool | Remarks                       |
|-----|-------------|--------------|-------------------------------|
| 1   | Holder      | VW 351       |                               |
| 2   | Hole plate  | -            | Made locally<br>(10 mm thick) |

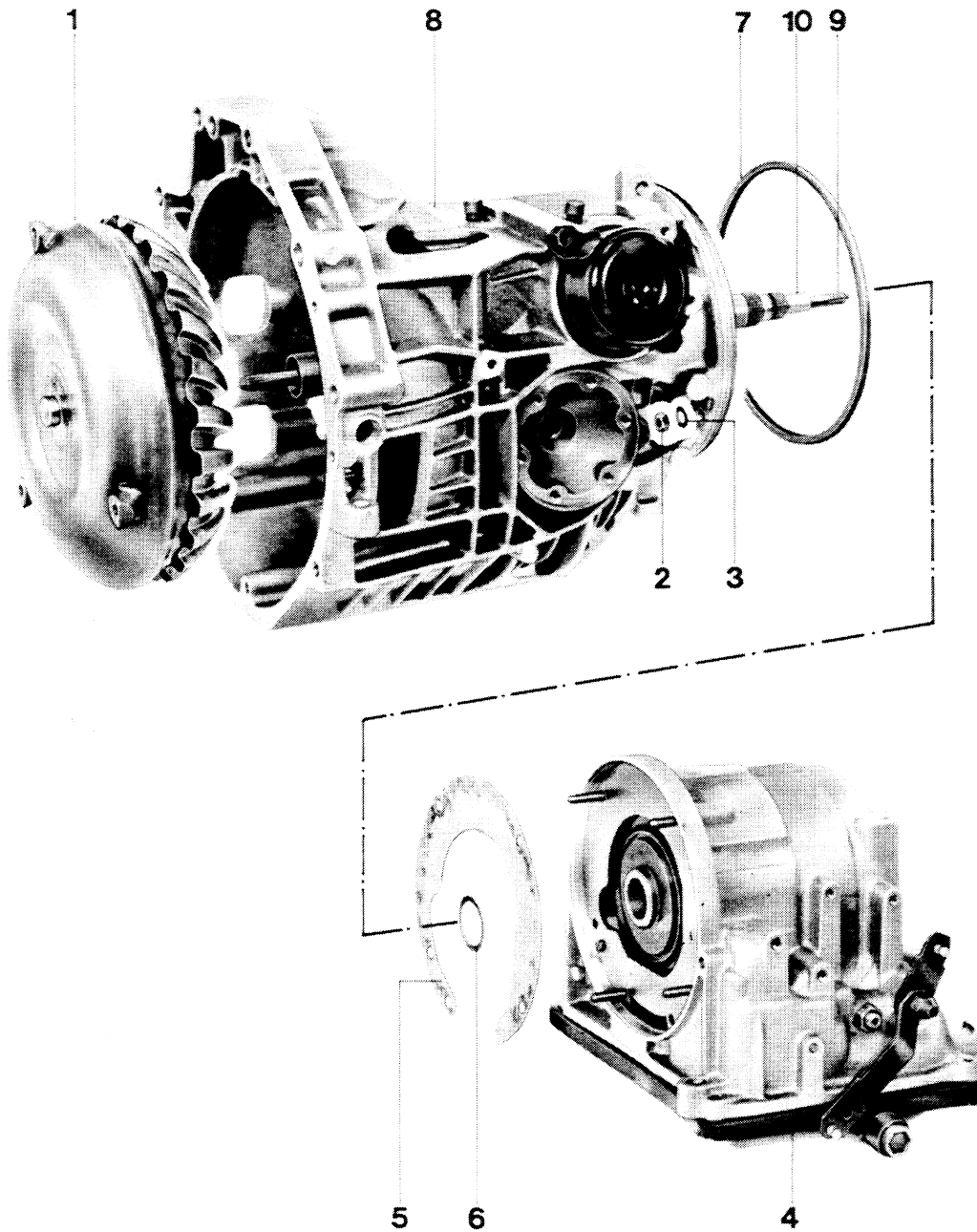

| No. | Description            | Qty. | Note When:   |  | Special Instructions |
|-----|------------------------|------|--|--|----------------------|
|     |                        |      | Removing   | Installing   |                      |
| 1   | Torque converter       | 1    |  |  |                      |
| 2   | Nut                    | 4    |  | Torque:<br>29 Nm (22 ft lb)  |                      |
| 3   | Spring washer          | 4    |  | Replace, if necessary  |                      |
| 4   | Automatic transmission | 1    |  |  |                      |
| 5   | Gasket                 | 1    |  | Replace  |                      |
| 6   | Shim                   | X    |  | Different thicknesses,<br>adjust axial play  |                      |
| 7   | Seal                   | 1    |  | Replace  |                      |
| 8   | Final drive            | 1    |  |  |                      |
| 9   | Oil pump shaft         | 1    |  | Check length. Insert in<br>pump splines to touch<br>bottom before<br>installing torque con-<br>verter. Be careful not<br>to damage seal in<br>turbine shaft. |                      |
| 10  | Turbine shaft          | 1    | Can only be<br>removed after<br>disconnecting<br>automatic trans-<br>mission | Check length;<br>check piston rings  |                      |

DISCONNECTING AND CONNECTING AUTOMATIC TRANSMISSION ON FINAL DRIVE

Disconnecting

Mount automatic transmission on assembly stand with holder VW 351 and disconnect final drive.

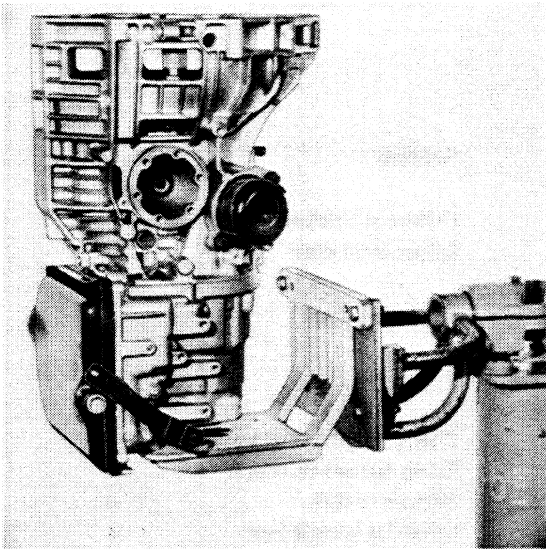

1 – Hole plate (made locally – sketch on page 38 - 3)

Connecting

Note:

Check axial play, adjusting if necessary, after repairing final drive or automatic transmission.

1. Length of front studs;  $a = 31.5$  mm.

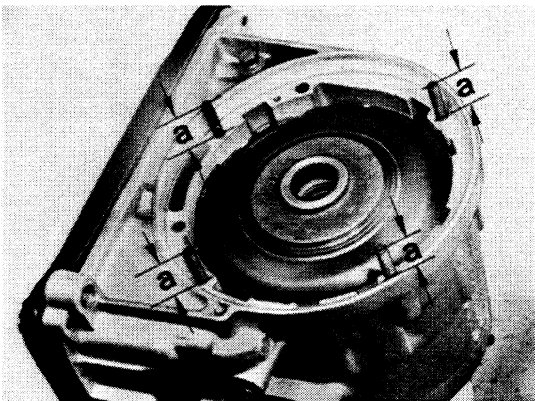

2. Check length of pump shaft.  
 $a = 513$  mm.

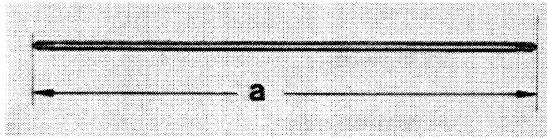

3. Check length of turbine shaft.  
 $a = 424.5$  mm.

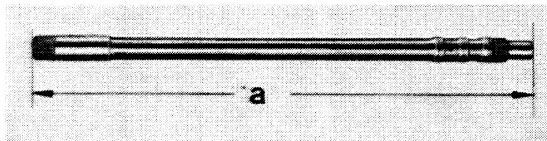

4. Make sure piston rings for turbine shaft are positioned correctly.

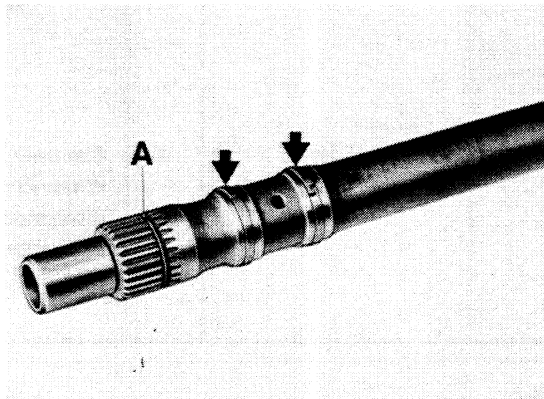

A – Wire ring

## REMOVING AND INSTALLING SEAL FOR TURBINE SHAFT

A seal is installed in the turbine shaft to prevent oil from running out of torque converter when engine is stopped.

These shafts have a groove all around for identification.

## Removing

Drive out seal with a standard internal-claw puller and an old oil pump shaft. A suitable round rod could also be used instead of pump shaft.

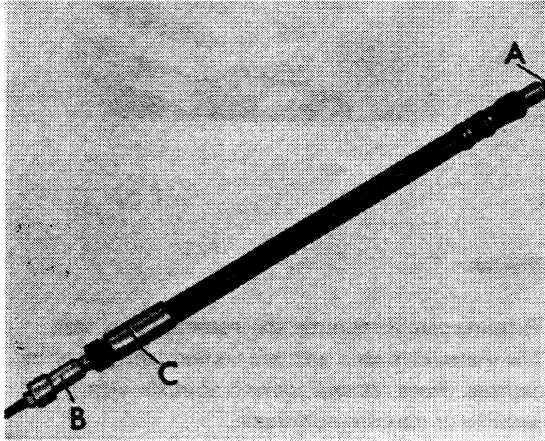

- A – Pump shaft
- B – Internal-claw puller
- C – Identification (groove)

## Installing

Drive in seal carefully with Special Tool 30 - 24. Sealing lip faces out.

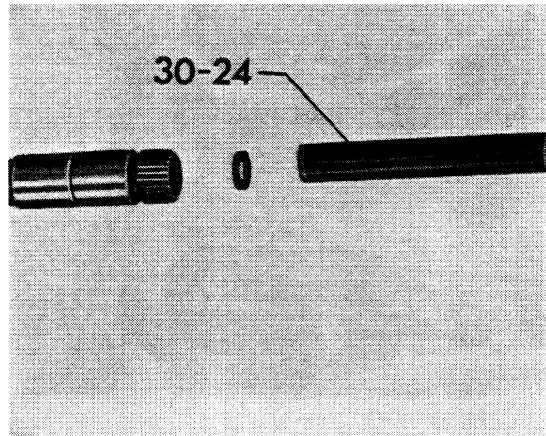

## REMOVING AND INSTALLING TORQUE CONVERTER SEAL

## Removing

Remove seal as shown in picture.

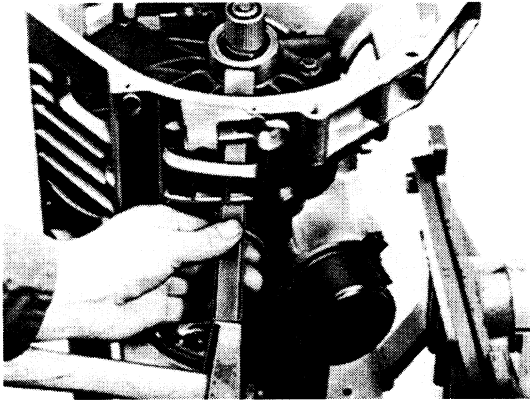

## Installing

Drive in seal with VW 192 or US 4450.

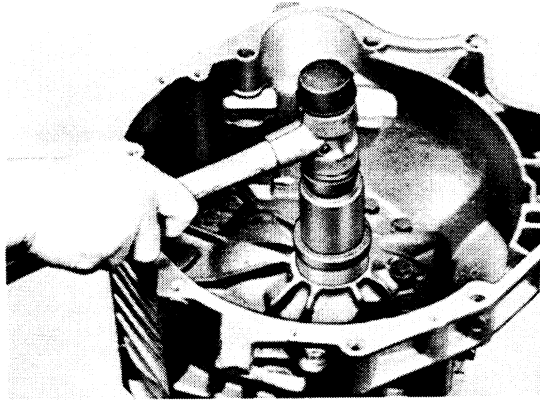

## Note:

Extreme care is required for installation of seal. The material is very soft and consequently easy to damage. Never let seal come in contact with gasoline or cleaning solutions.

## ADJUSTING AXIAL PLAY OF AUTOMATIC TRANSMISSION / FINAL DRIVE

Axial play "y" between automatic transmission and final drive has to be adjusted to limit the axial travel of the ring gear.

## Measuring Points:

- a – Final drive:  
case sealing surface to bushing for seals.
- b – Automatic transmission:  
bearing collar for shim to intermediate plate with gasket.

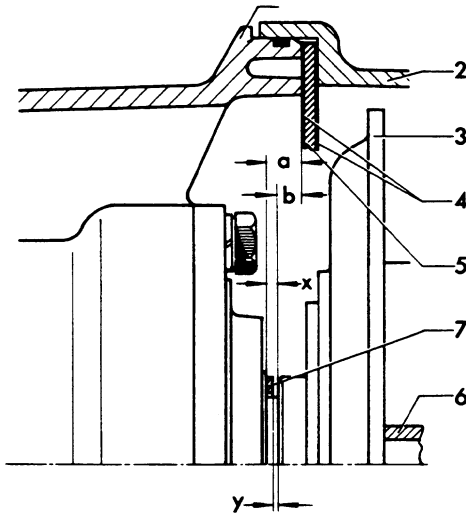

- 1 – Final drive  
2 – Automatic transmission  
3 – Ring gear  
4 – Gaskets  
5 – Intermediate plate  
6 – Drive pinion  
7 – Shim

## Procedures

1. Measure distance "a" on final drive.  
Place straight-edge on case and measure distance to bushing for seals.

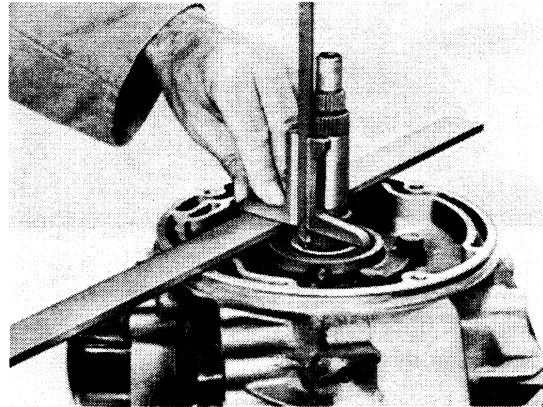

2. Measure distance from straight-edge to case sealing surface.

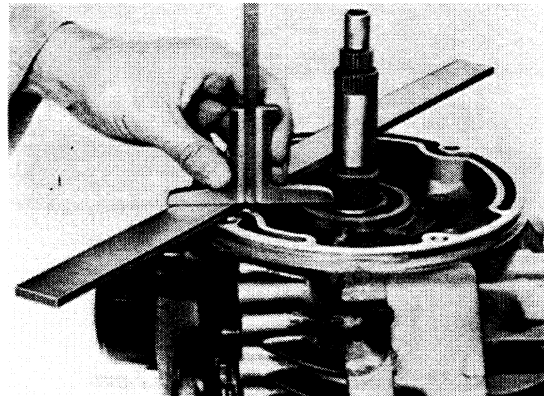

## Example:

|                                  |                |
|----------------------------------|----------------|
| Straight-edge to bushing         | 18.7 mm        |
| Straight-edge to sealing surface | – 8.0 mm       |
| Case distance "a" =              | <u>10.7 mm</u> |

3. Measure distance "b" on automatic transmission.  
Place straight-edge on case and measure distance to gasket.

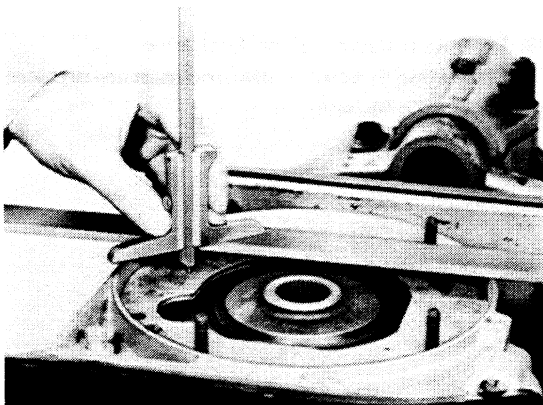

4. Measure distance from straight-edge to bearing collar for shim.

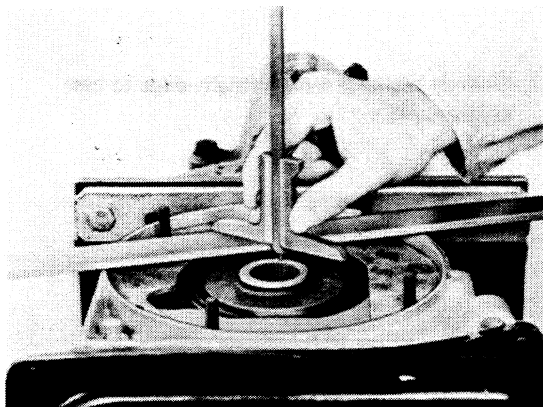

Example:

|                |          |
|----------------|----------|
| Distance "a"   | 10.7 mm  |
| Distance "b"   | - 9.2 mm |
| Distance "x" = | 1.5 mm   |

5. Select shim size according to table.

| Distance "x" (mm) | Shim (mm) |
|-------------------|-----------|
| 0.23 ... 0.84     | none      |
| 0.85 ... 1.24     | 1 x 0.4   |
| 1.25 ... 1.64     | 2 x 0.4   |
| 1.65 ... 2.04     | 1 x 1.2   |
| 2.05 ... 2.44     | 1 x 0.4   |
|                   | 1 x 1.2   |
| 2.45 ... 2.84     | 2 x 0.4   |
|                   | 1 x 1.2   |
| 2.85 ... 3.24     | 2 x 1.2   |
| 3.25 ... 3.64     | 1 x 0.4   |
|                   | 2 x 1.2   |
| 3.65 ... 3.88     | 2 x 0.4   |
|                   | 2 x 1.2   |

Shims are available in thicknesses of 0.4 mm and 1.2 mm.

Example:

|                                 |           |
|---------------------------------|-----------|
| Straight-edge to gasket         | 19.2 mm   |
| Straight-edge to bearing collar | - 10.0 mm |
| Distance "b" =                  | 9.2 mm    |

Determine distance "x":

Distance "b" subtracted from distance "a" = distance "x".



DISASSEMBLING AND ASSEMBLING AUTOMATIC TRANSMISSION

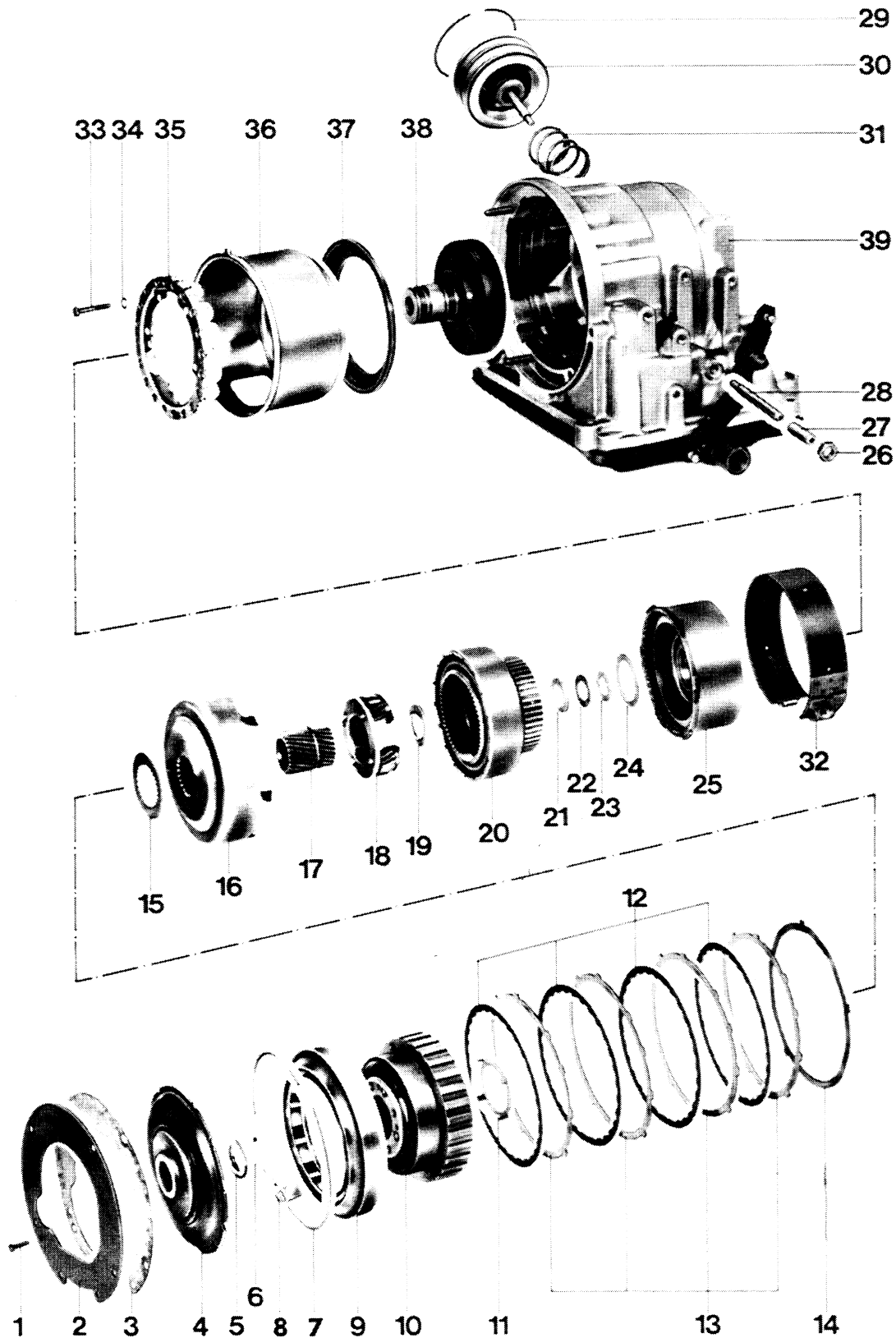

| No. | Description                              | Qty. | Note when:                             |  |
|-----|--|------|--|--|
|     |  |      | Removing                               | Installing   |
| 1   | Screw                                    | 1    |  | Torque:<br>3.5 Nm  |
| 2   | Intermediate plate                       | 1    |  | Check, adjusting if necessary, axial play of automatic transmission/final drive after installation                           |
| 3   | Gasket                                   | 1    |  | Replace  |
| 4   | Ring gear (2-piece)                      | 1    |  |  |
| 5   | Axial needle bearing                     | 1    |  |  |
| 6   | Thrust washer                            | 1    |  |  |
| 7   | Circlip                                  | 1    |  | Position correctly, push in with end of hammer handle if necessary   |
| 8   | Holding wedge                            |      |  | Opening must be opposite holding wedge. Automatic transmission is assembled correctly when groove for circlip is accessible. |
| 9   | One-way clutch                           | 1    | Remove with reverse planetary gear set | Turn planetary gear set and press on one-way clutch simultaneously. It should not be possible to turn it anticlockwise.      |
| 10  | Reverse planetary gear set               | 1    |  | Insert before installing plates  |
| 11  | Thrust washer                            | 1    |  | Hold on planetary gear set with grease   |
| 12  | Inner plate (1st and reverse gear brake) | 4    |  | Check identification. Place in ATF 15 min. before installing.  |
| 13  | Outer plate (1st and reverse gear brake) | 4    |  |  |

| No. | Description                | Qty. | Note when: |   |
|-----|----------------------------|------|------------|---|
|     |                            |      | Removing   | Installing  |
| 14  | Corrugated washer *        | 1    |            |   |
| 15  | Thrust washer<br>(steel)   | 1    |            |   |
| 16  | Drive shell                | 1    |            |   |
| 17  | Sun gear                   | 1    |            | Short half faces forward planetary gear set         |
| 18  | Forward planetary gear set | 1    |            |   |
| 19  | Axial needle bearing       | 1    |            |   |
| 20  | Forward clutch             | 1    |            | Assemble with D and R clutches and install together |
| 21  | Bearing ring               | 1    |            | Hollow side faces bearing cage                      |
| 22  | Bearing cage               | 1    |            |   |
| 23  | Bearing ring               | 1    |            | Tabs face bearing cage                              |
| 24  | Thrust washer              | 1    |            | Hold on D and R clutch with a little grease         |
| 25  | Direct and reverse clutch  | 1    |            | Assemble with forward clutch and install together   |
| 26  | Nut                        | 1    |            | Torque:<br>20 Nm                                    |
| 27  | Adjusting screw            | 1    |            |   |
| 28  | Support                    | 1    |            |   |
| 29  | Circlip                    | 1    |            |   |

| No. | Description                             | Qty. | Note when:  |   |
|-----|---|------|---|---|
|     |   |      | Removing  | Installing                                      |
| 30  | Cover with piston                       | 1    | Remove before removing brake band. Remove by applying light taps from rubber hammer on cover surface. |   |
| 31  | Spring                                  | 1    |   |   |
| 32  | Brake band<br>(2nd gear brake)          | 1    |   | Adjust  |
| 33  | Bolt<br>M 6 x 35                        | 5    |   | Torque:<br>7.0 Nm                               |
| 34  | Lock washer**                           | 5    |   | Replace, if necessary                           |
| 35  | Spring retainer with<br>20 springs      | 1    |   |   |
| 36  | Shell*                                  | 1    |   | Check length,<br>position correctly             |
| 37  | Piston (1st and<br>reverse gear brake)* | 1    |   | Sealing lips face case<br>floor, check function |
| 38  | Pump with thrust<br>washer              | 1    |   |   |
| 39  | Transmission case                       | 1    |   |   |

\* See change on Page 38 - 18 a

\*\* Dropped as from October 1982

## DISASSEMBLING AND ASSEMBLING AUTOMATIC TRANSMISSION

## Disassembling

1. Take circlip out of groove.

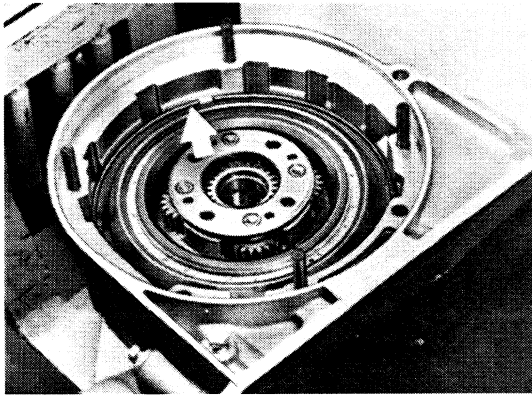

2. Remove circlip and end cover as well as piston for 2nd gear brake by applying light taps on base of cover with a rubber hammer.

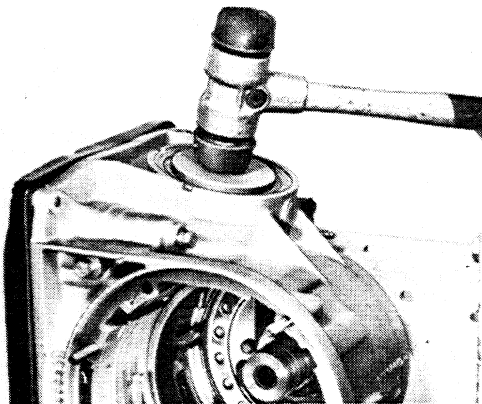

## Assembling

1. Slide piston for 1st and reverse gear brake on to pump housing and install both together. Thin rib (arrow) faces up. Place pump shaft in drive dog and turn pump. It should be possible to turn pump by hand without resistance.

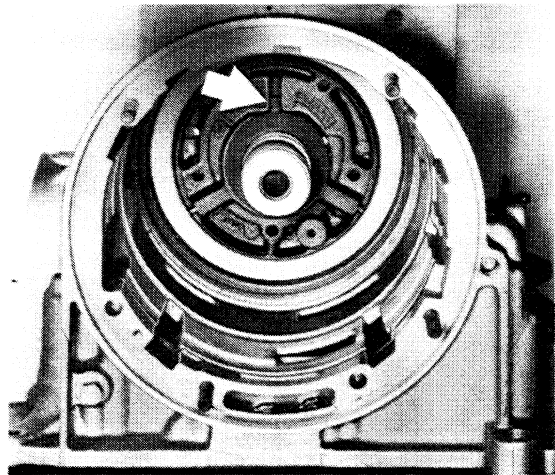

2. Install shell for 1st and reverse gear brake in correct position (see arrow).

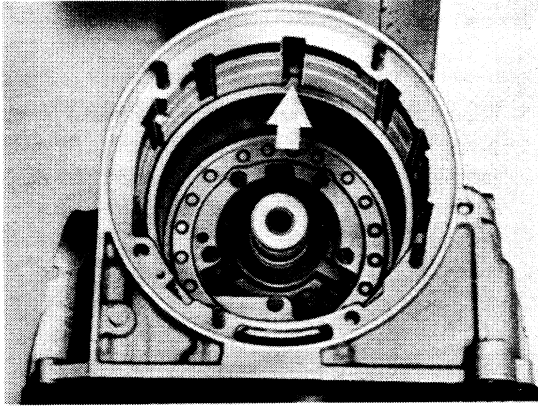

Note:

Shell length distance "a" = 94.9 mm.

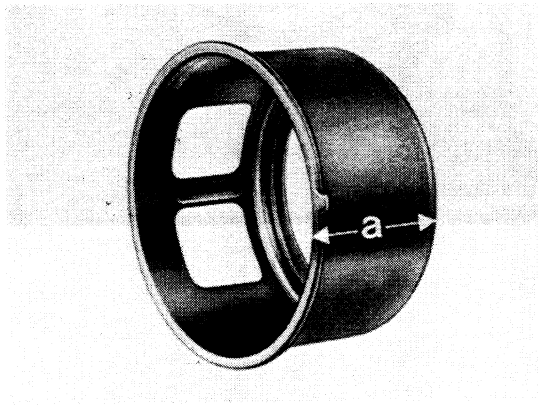

3. Place springs on spring retainer and install spring retainer with springs in case from underneath. Tighten bolts.

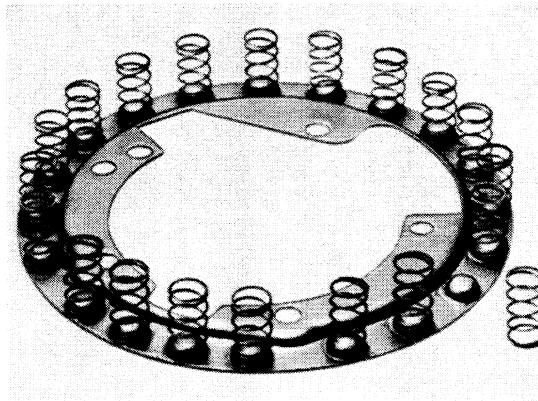

4. Check function of 1st and reverse gear brake. Apply compressed air in pressure bore (arrow). Piston should compress the springs. Without compressed air the piston should return to starting position.

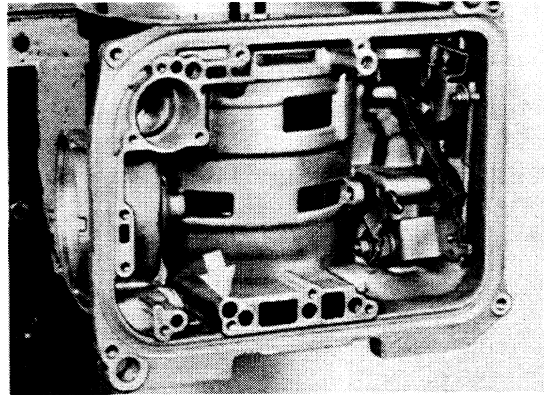

5. Install piston and end cover for 2nd gear brake and mount circlip. Press down piston and end cover with a suitable tool.

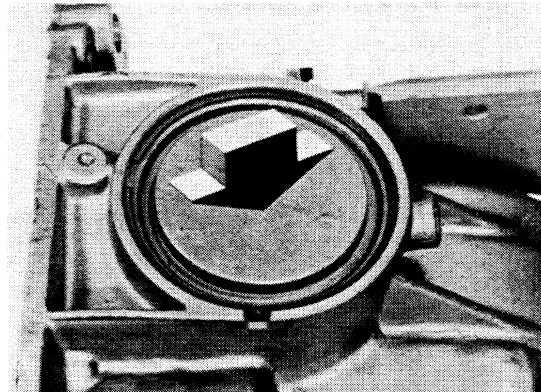

6. Install clutches. Assemble direct and reverse clutch with forward clutch outside of transmission and then slide clutch on to neck of oil pump with case opening facing down at an angle. Swing case to have opening facing up again.

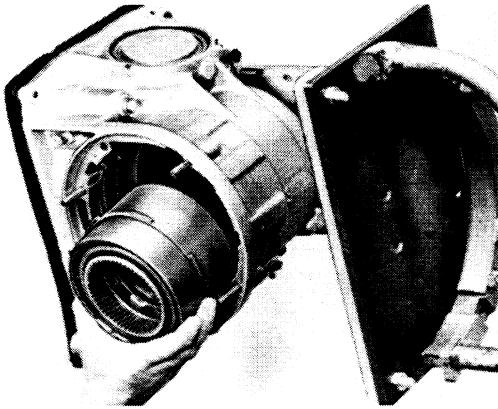

7. Check function of 2nd gear brake by applying compressed air in the pressure bore (arrow). Piston should compress the brake band (D + R clutch). Piston must return to its starting position without compressed air.

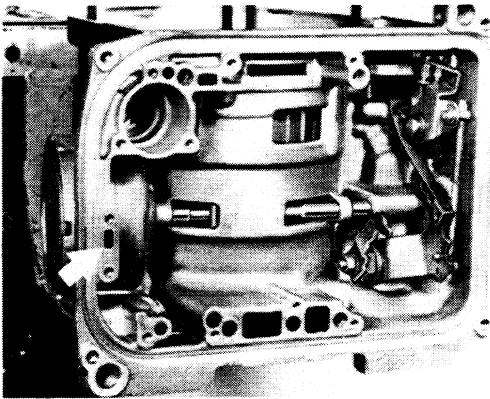

8. Install reverse planetary gear set. Then install corrugated washer and plates.

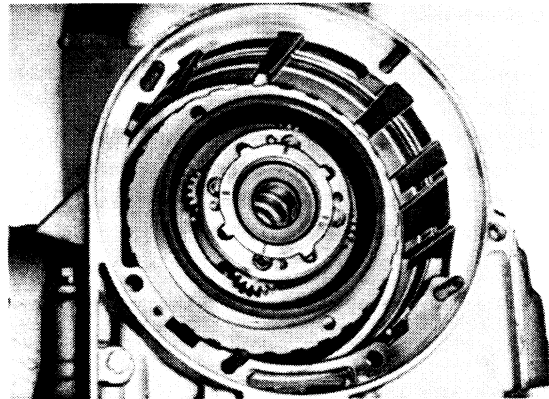

9. Install pre-assembled one-way clutch by turning planetary gear set in direction of arrow and pressing in one-way clutch at same time.

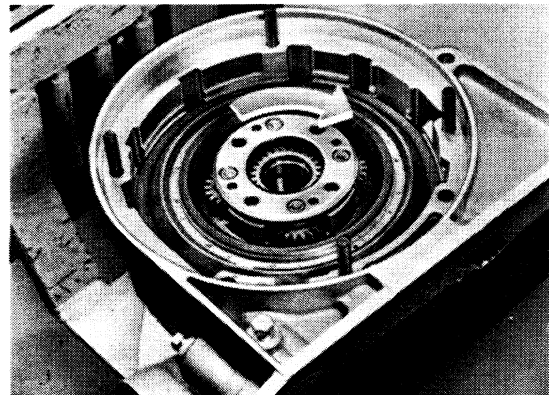

### Checking One-way Clutch

It should not be possible to turn planetary gear set anticlockwise.

10. Install retaining wedge for one-way clutch, pressing in with end of hammer handle if necessary, and mount circlip with opening opposite the retaining wedge.

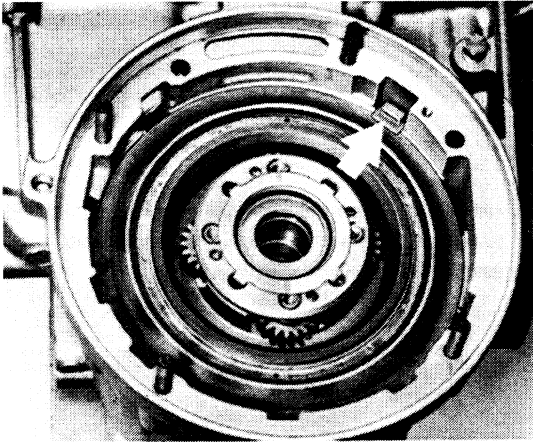

Parts have been assembled correctly, if groove for circlip is accessible.

11. Recheck function of 1st and reverse gear brake by applying compressed air (see point 4).

12. Adjust 2nd gear brake. Tighten adjusting screw to initial torque of 10 Nm (7 ft lb), loosen again and tighten finally to 5 Nm (3.6 ft lb). Now turn adjusting screw exactly two turns

*anticlockwise  
counterclockwise*

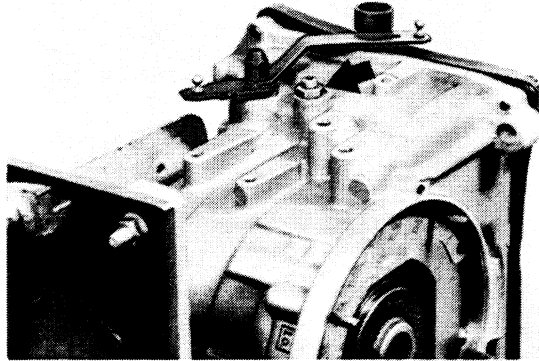

#### Note :

Only adjust brake band with transmission positioned horizontally, since otherwise brake band would jam.



**MODIFICATIONS**

Corrugated washer for first gear brake dropped.

Insert shell. Bore (arrow) must be flush with ball valve.

Note

From March 1983, corrugated washer (Item 14) has been dropped, length of shell (Item 36) changed and piston (Item 37) equipped with a ball valve.

Wet piston with ATF and insert in transmission case so that ball valve of piston (arrow 2) is flush with transmission case bore (arrow 1).

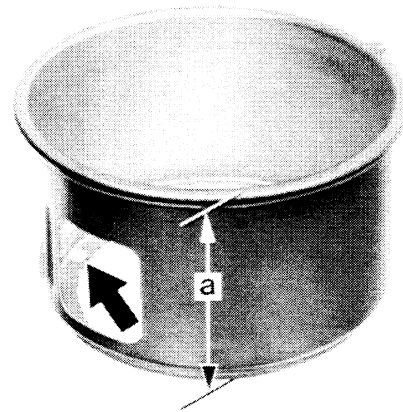

Pay attention to length of shell  
Dimension "a" = 97.2 mm

The new piston with ball valve and the shell with bore can also be installed later without corrugated washer, even in previous transmissions.

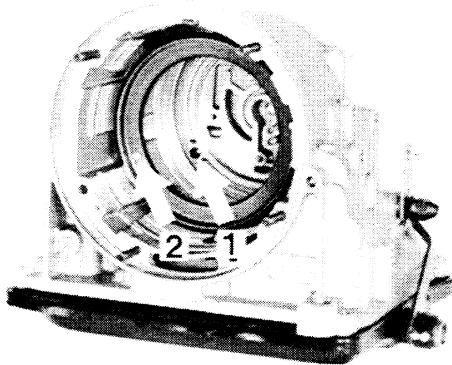

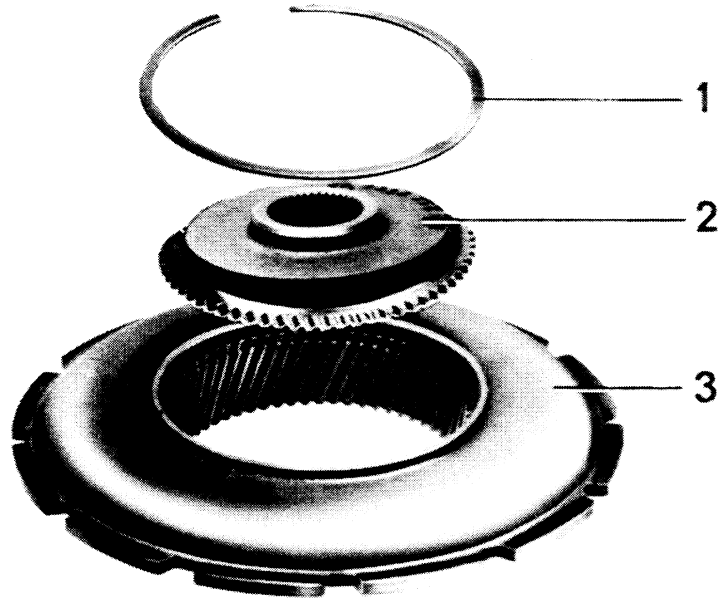

| No. | Description       | Qty. | Removing | Note When:<br>Installing                   | Special<br>Instructions |
|-----|-------------------|------|----------|--|-------------------------|
| 1   | Circlip           | 1    |          |  |                         |
| 2   | Hub for ring gear | 1    |          |  |                         |
| 3   | Ring gear         | 1    |          | Check catches for<br>parking lock for wear |                         |

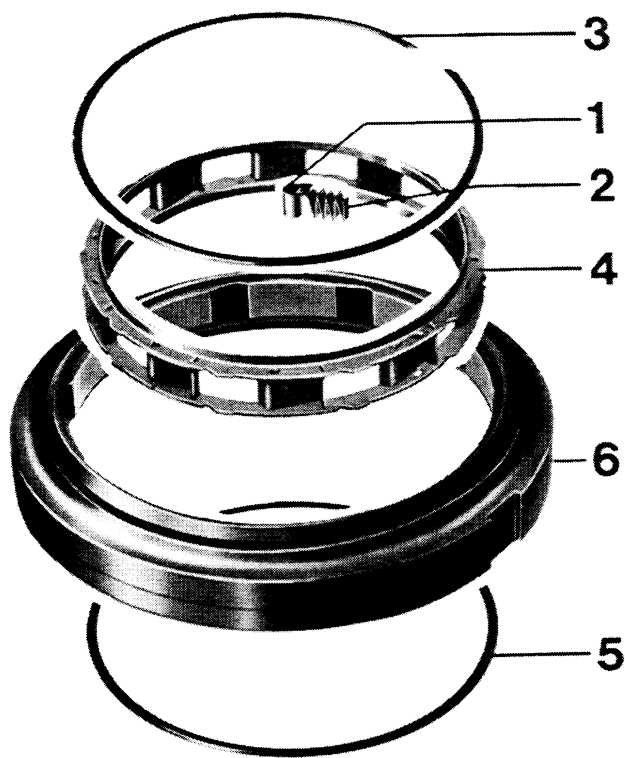

| No. | Description | Qty. | Note When:                        |  | Special Instructions |
|-----|-------------|------|-----------------------------------|--|----------------------|
|     |             |      | Removing                          | Installing   |                      |
| 1   | Roller      | 10   |                                   | Position correctly                                     |                      |
| 2   | Spring      | 10   |                                   | Guide lug faces roller                                 |                      |
| 3   | Circlip     | 1    |                                   |  |                      |
| 4   | Cage        | 1    | Drive out carefully with a hammer | Heat outer race to approx. 150 °C (300 °F) and install |                      |
| 5   | Circlip     | 1    |                                   |  |                      |
| 6   | Outer race  | 1    |                                   |  |                      |

## DISASSEMBLING AND ASSEMBLING ONE-WAY CLUTCH

## Disassembling

Drive out cage carefully with a hammer.

## Assembling

1. Install lower circlip.

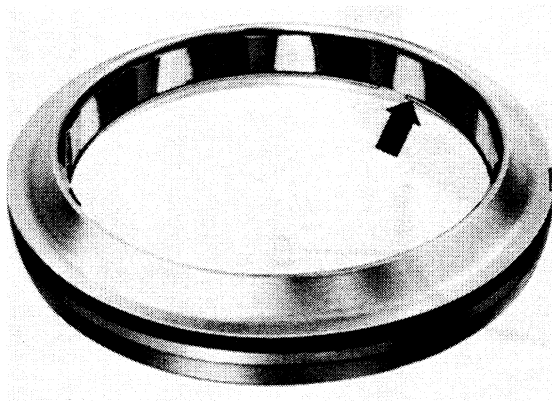

2. Insert cage for one-way clutch. Heat outer race to approx. 150 °C (300 °F), which requires that the hotplate itself has a temperature of 190 °C (375 °F). Take hold of cage on upper collar with 2 pliers, remove quickly from hotplate and install in outer race. Make sure short sides of cage retaining tabs are aligned with matching contours in outer race (arrow). If necessary, turn accordingly immediately after installing.

## Note :

The cage will take on the heat of the outer race quickly and then fit tight. If cage does not fit correctly on lower circlip and in contour of outer race, do not attempt to force it into correct position. Instead drive it out carefully, let it cool down and install it again.

3. Install springs and rollers. Check for correct installed position. Seen clockwise the spring will be in front of the roller.

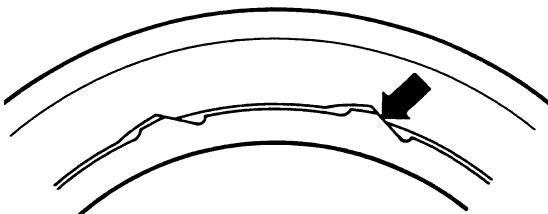
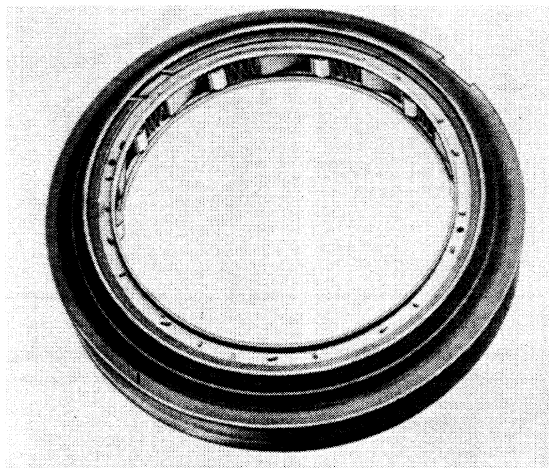

## DISASSEMBLING AND ASSEMBLING FREEWHEEL WITH PLASTIC CAGE

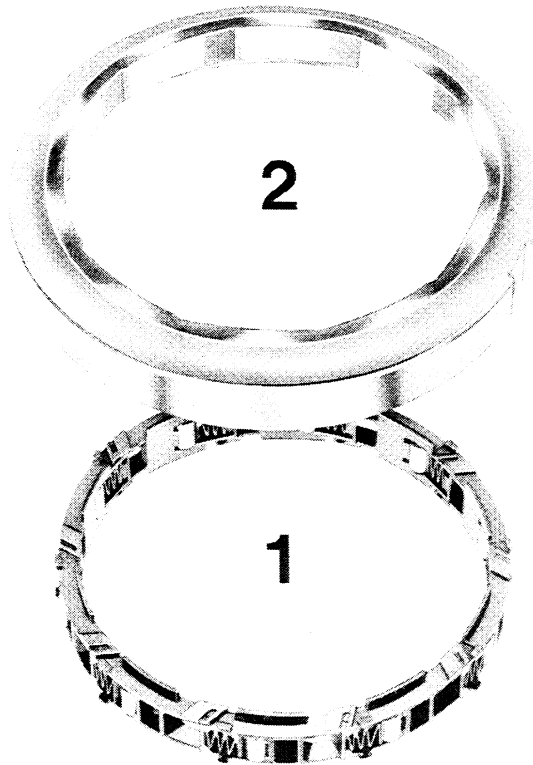

| No. | Description                   | Qty. | Note when:                |  |
|-----|-------------------------------|------|---------------------------|--|
|     |                               |      | Removing                  | Installing   |
| 1   | Cage with rollers and springs | 1    | Turn and remove downwards | Insert into outer race in correct position from below. Lock by turning |
| 2   | Outer race                    | 1    |                           |  |

## ASSEMBLY NOTES FOR DISASSEMBLY AND ASSEMBLY

Disassembly

Unlock cage by turning in direction of arrow and remove downwards.

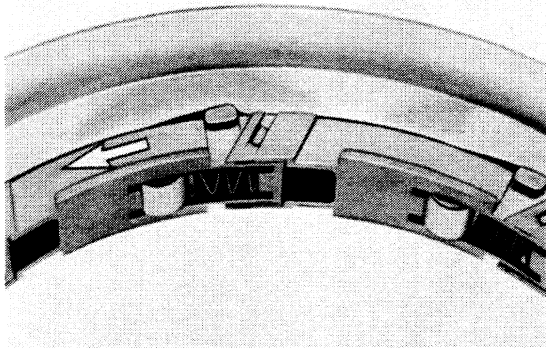

2. Install springs and rollers. Pay attention to correct installation position. In clockwise direction, spring is located before roller. Install guide lug (arrow) as shown with respect to rollers.

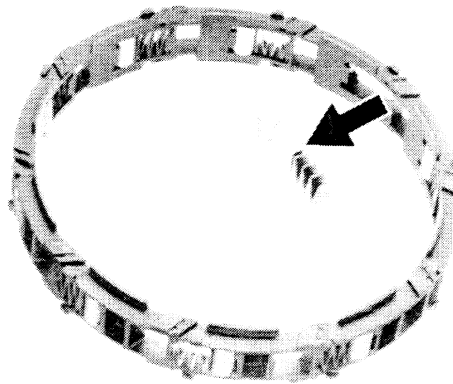
Assembly

1. Combine 10 segments in one ring.

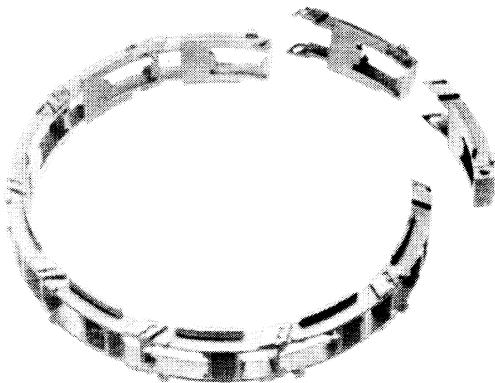

3. Insert cage with rollers into outer race in correct position from below (arrow direction A).

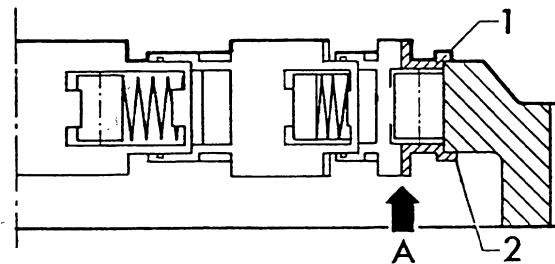

1 = Small retaining lugs pointing upwards

2 = Large retaining lugs pointing downwards

4. Lock cage by turning in direction of arrow.

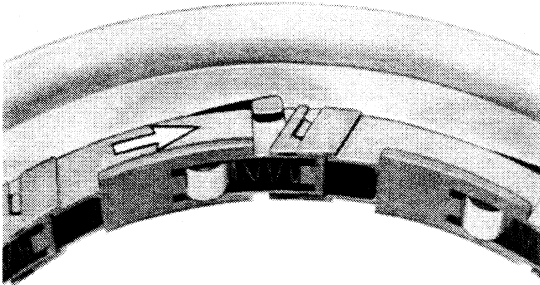

## TOOLS

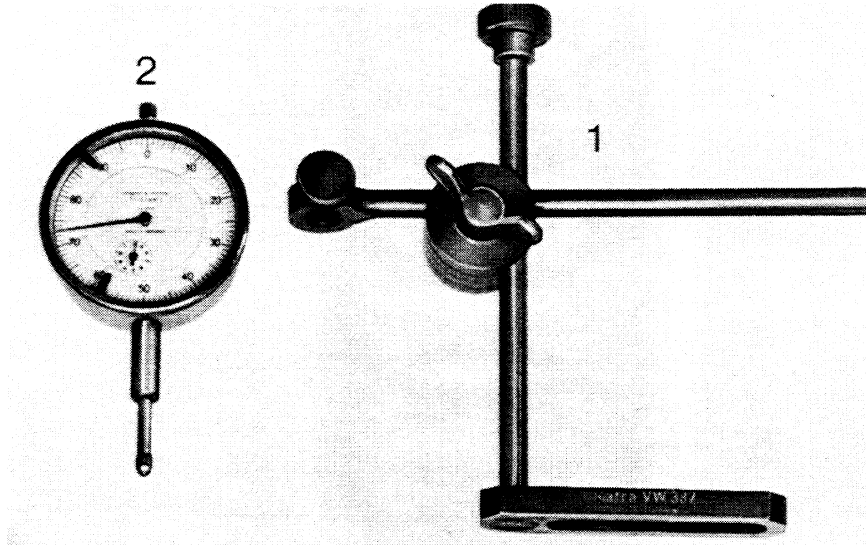

| No. | Description       | Special Tool | Remarks  |
|-----|-------------------|--------------|----------|
| 1   | Dial gauge holder | VW 387       |          |
| 2   | Dial gauge        | —            | Standard |



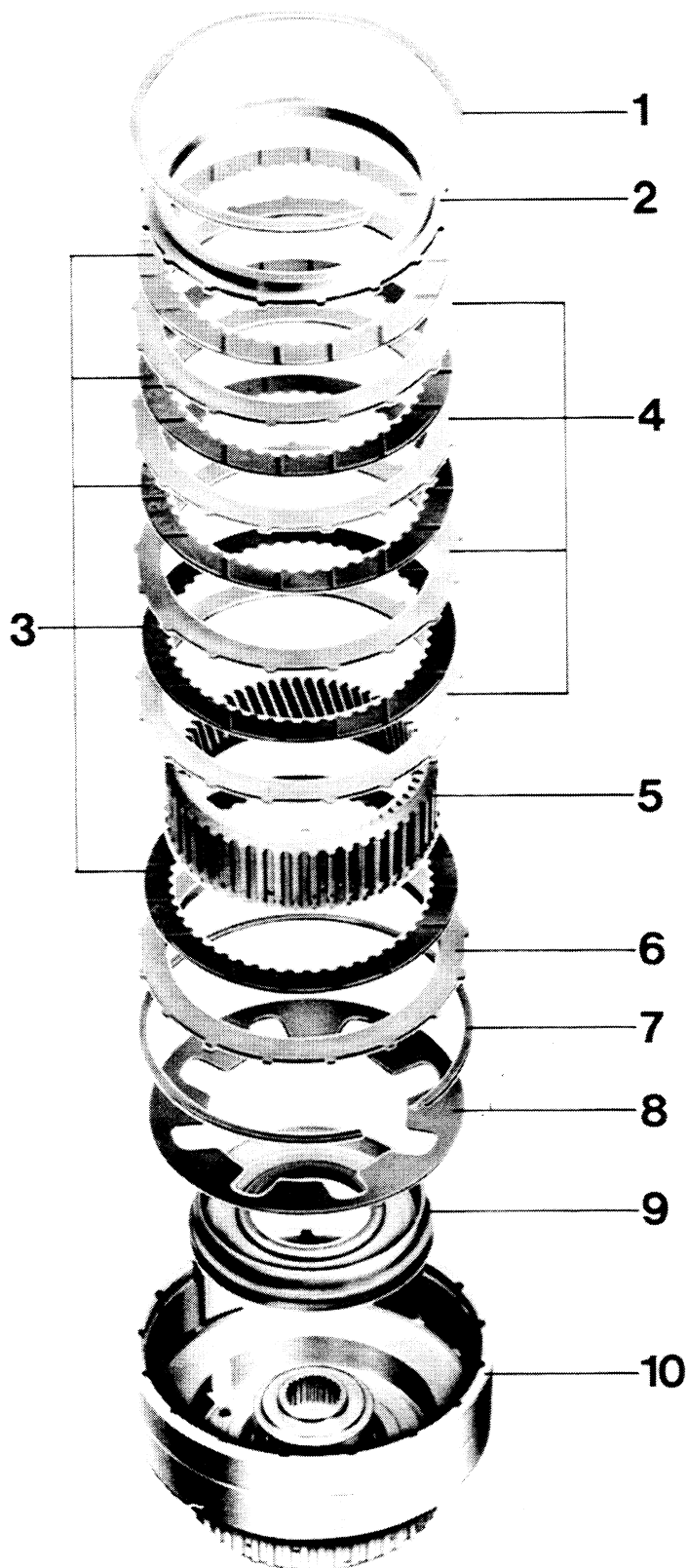

| No. | Description      | Qty. | Note When: |   | Special Instructions |
|-----|------------------|------|------------|---|----------------------|
|     |                  |      | Removing   | Installing  |                      |
| 1   | Circlip          | 1    |            |   |                      |
| 2   | Pressure plate   | X    |            | Different thicknesses, adjust axial play  |                      |
| 3   | Inner plate      | 5    |            | Install only plates with specified lining. Place new plates in ATF 15 minutes before installing                                 |                      |
| 4   | Outer plate      | 4    |            | Check for wear, slight blue discoloration is not significant  |                      |
| 5   | Ring gear        | 1    |            | Insert pressure plate and one inner plate before installing (below retaining edge in external spline)                           |                      |
| 6   | Pressure plate   | 1    |            | Smooth surface faces plate assembly   |                      |
| 7   | Circlip          | 1    |            | Diaphragm spring should already get slight preload from installed circlip; replace diaphragm spring if necessary                |                      |
| 8   | Diaphragm spring | 1    |            | Curved surface (small diameter) faces base of clutch  |                      |
| 9   | Piston           | 1    |            | Sealing lips are vulcanized; coat sealing lips with ATF before installing   |                      |
| 10  | Clutch drum      | 1    |            | Measure position of groove for circlip. Check ball valve — in direction of arrow = tight, in opposite direction of arrow = open |                      |

## DISASSEMBLING AND ASSEMBLING FORWARD CLUTCH

## Disassembling

1. Remove circlip and take all parts out of clutch drum.

## Assembling

1. Measure location of groove for circlip. Distance "a" = 29.8 mm. There are different version, consequently only install a clutch drum with correct distance "a".

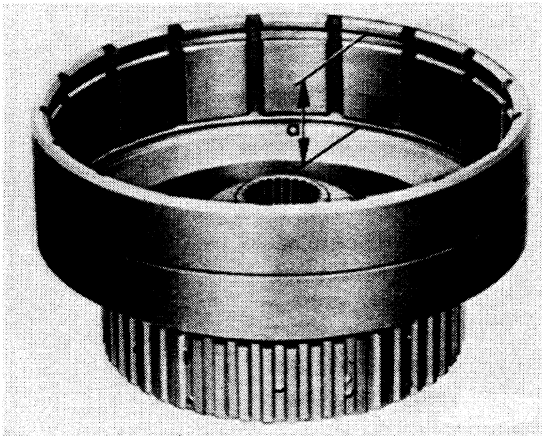

2. Only install inner plates, the linings of which have grooves as shown in the picture. Place new lined plates in ATF 15 minutes before installing.

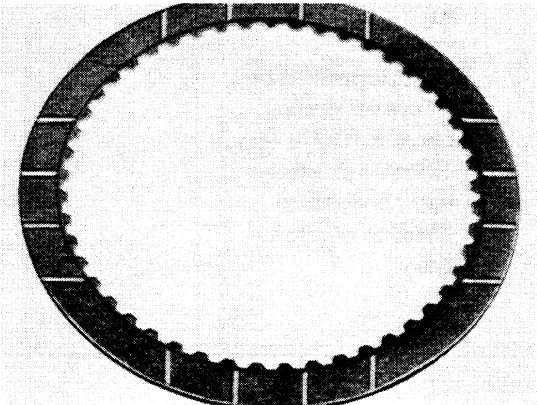

3. Measure axial play of forward clutch.  
Specification: 0.50 . . . 0.90 mm.

The following pressure plates are available for adjustments.

2.30 mm, 2.70 mm, 3.10 mm, 3.50 mm and 3.90 mm thick.

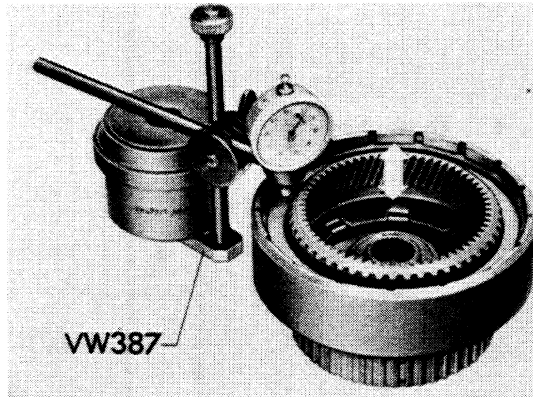

4. Check function of assembled forward clutch. This is done by placing both clutches (forward and D + R clutches) with thrust washers on an oil pump and applying compressed air in pressure bore (arrow A). Piston should be heard to compress the plate assembly. Piston must return to its starting position when supply of compressed air is stopped.

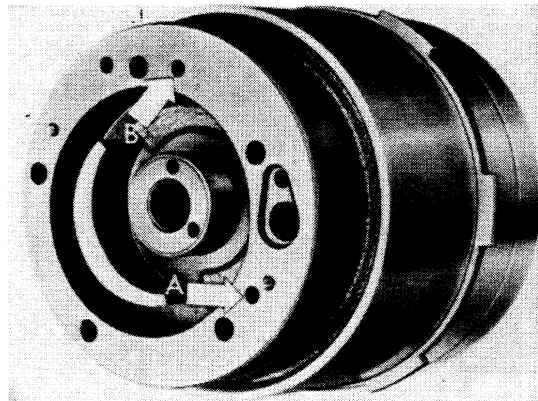

## TOOLS

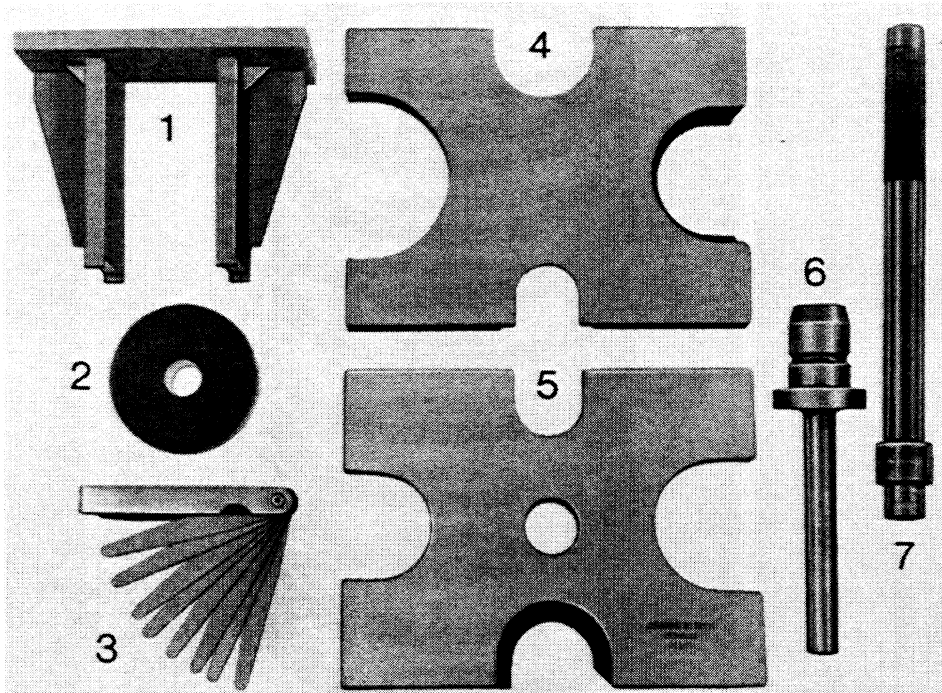

| No. | Description        | Special Tool | Remarks       |
|-----|--------------------|--------------|---------------|
| 1   | Bridge             | VW 460/3     | Standard tool |
| 2   | Thrust pad         | VW 433       |               |
| 3   | Feeler blade gauge | —            |               |
| 4   | Thrust plate       | VW 402       |               |
| 5   | Thrust plate       | VW 401       |               |
| 6   | Punch              | VW 411       |               |
| 7   | Drift              | VW 295       |               |

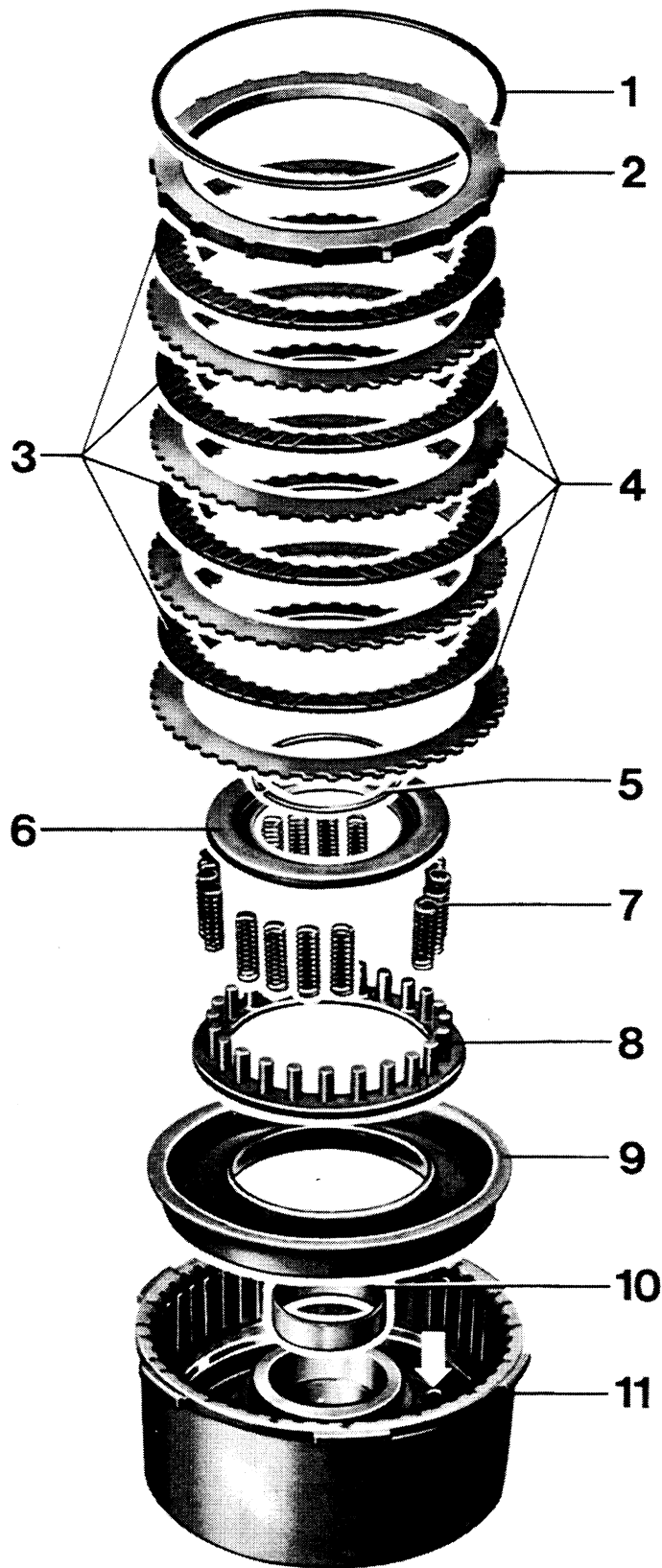

| No. | Description     | Qty. | Note When:   |   | Special Instructions |
|-----|-----------------|------|--|---|----------------------|
|     |                 |      | Removing   | Installing  |                      |
| 1   | Circlip         | X    |  | Different thicknesses, adjust axial play  |                      |
| 2   | Pressure plate  | 1    |  |   |                      |
| 3   | Inner plate     | 4    |  | Only install plates with specified lining. Place new plates in ATF for 15 minutes before installing   |                      |
| 4   | Outer plate     | 4    |  | Check for wear; replace even if wear is only slight (blue discoloration)  |                      |
| 5   | Circlip         | 1    | Remove with VW 460/3   | Install with VW 460/3. Make sure of correct fit   |                      |
| 6   | Spring retainer | 1    |  |   |                      |
| 7   | Spring          | 16   |  | Distribute around circumference uniformly in 4 groups of 4 each   |                      |
| 8   | Spring retainer | 1    |  |   |                      |
| 9   | Piston          | 1    |  | Coat sealing lips with ATF  |                      |
| 10  | Bushing         | 1    | Remove with a standard puller (e. g. Kukko No. 21/6 - 37 ... 46 mm) and VW 295 | Press in with VW 295 and VW 433   |                      |
| 11  | Clutch drum     | 1    |  | Check ball valve with compressed air – in direction of arrow = closed, in opposite direction of arrow = open. Apply compressed air in direction of arrow. |                      |

## DISASSEMBLING AND ASSEMBLING DIRECT AND REVERSE CLUTCH

## Disassembling

1. Remove circlip by pressing down spring retainer with VW 460/3 and taking circlip out of groove

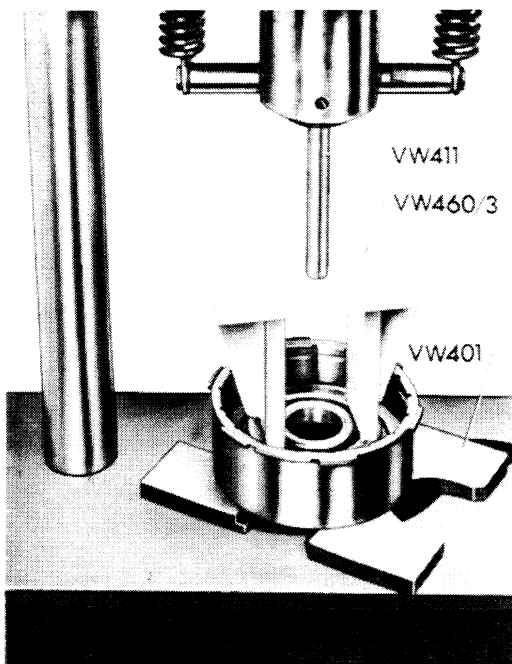

3. Remove bearing bushing with VW 295 and a standard puller, e.g. Kukko No. 21/6 (37 . . . 46 mm).

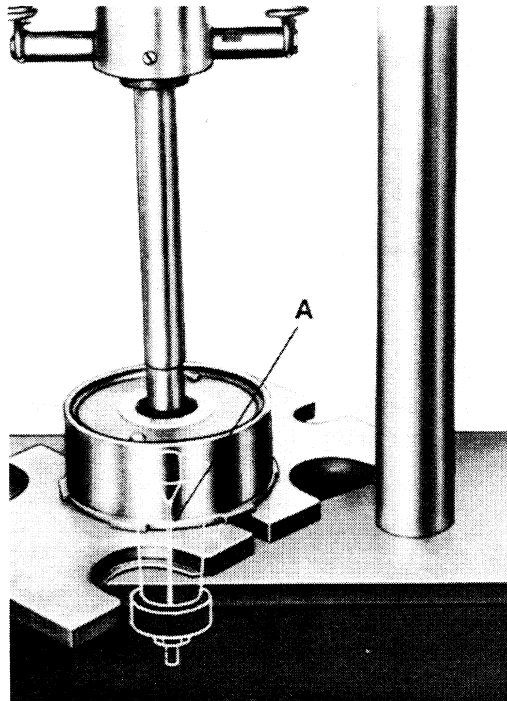

- A - Standard internal-claw puller  
e.g. Kukko No. 21/6 (37 - 46 mm)

2. Remove piston by turning and pulling out.

## Assembling

1. Check the ball valve for leakage (see page 38-29, Item 11).

2. Press in bearing bushing flush at first with VW 433. Then press in new bushing to correct depth (1.7 mm below upper edge) with an old bushing.

3. Adjust axial play of D + R clutch.

Specification: 2.05 . . . 2.50 mm.

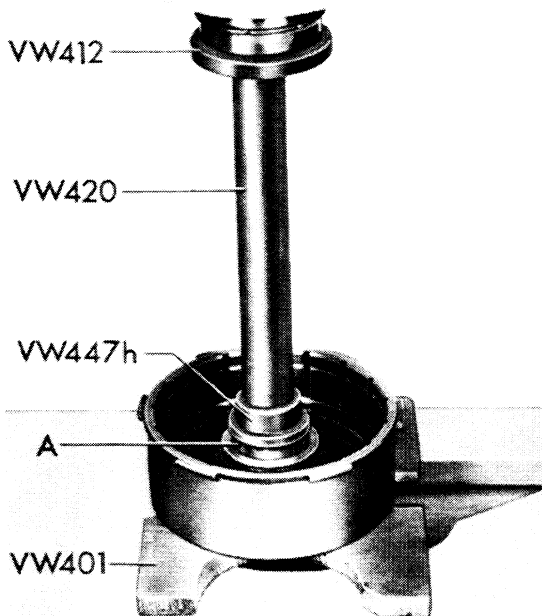

A – Old bushing (applied on new bushing)

Note :

Only install inner plates, the linings of which are identified as shown in the picture.

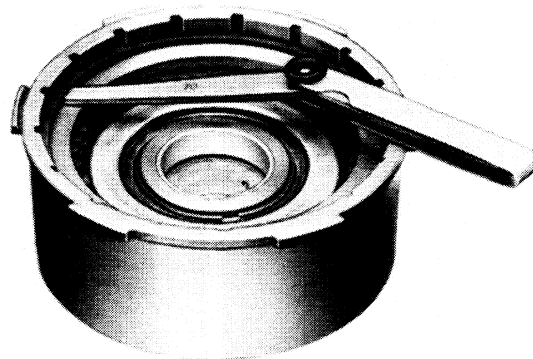

Different size circlips are available for adjustment.

Thickness: 1.5 mm, 1.7 mm, 2.0 mm, 2.3 mm and 2.5 mm.

4. Check function of assembled D + R clutch.

This is done by placing both clutches (forward and D + R clutches) with thrust washers on an oil pump and applying compressed air in pressure bore (arrow B). Piston must be heard to compress the plate assembly. Piston should return to its starting position when stopping the supply of compressed air.

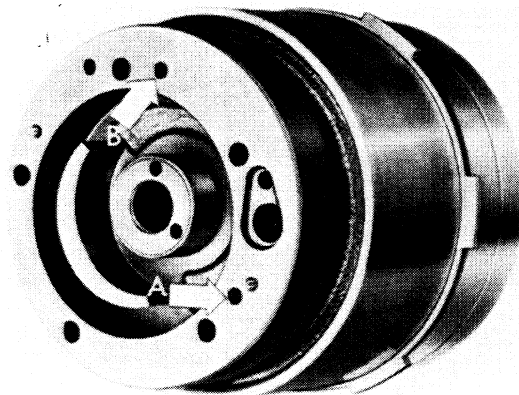



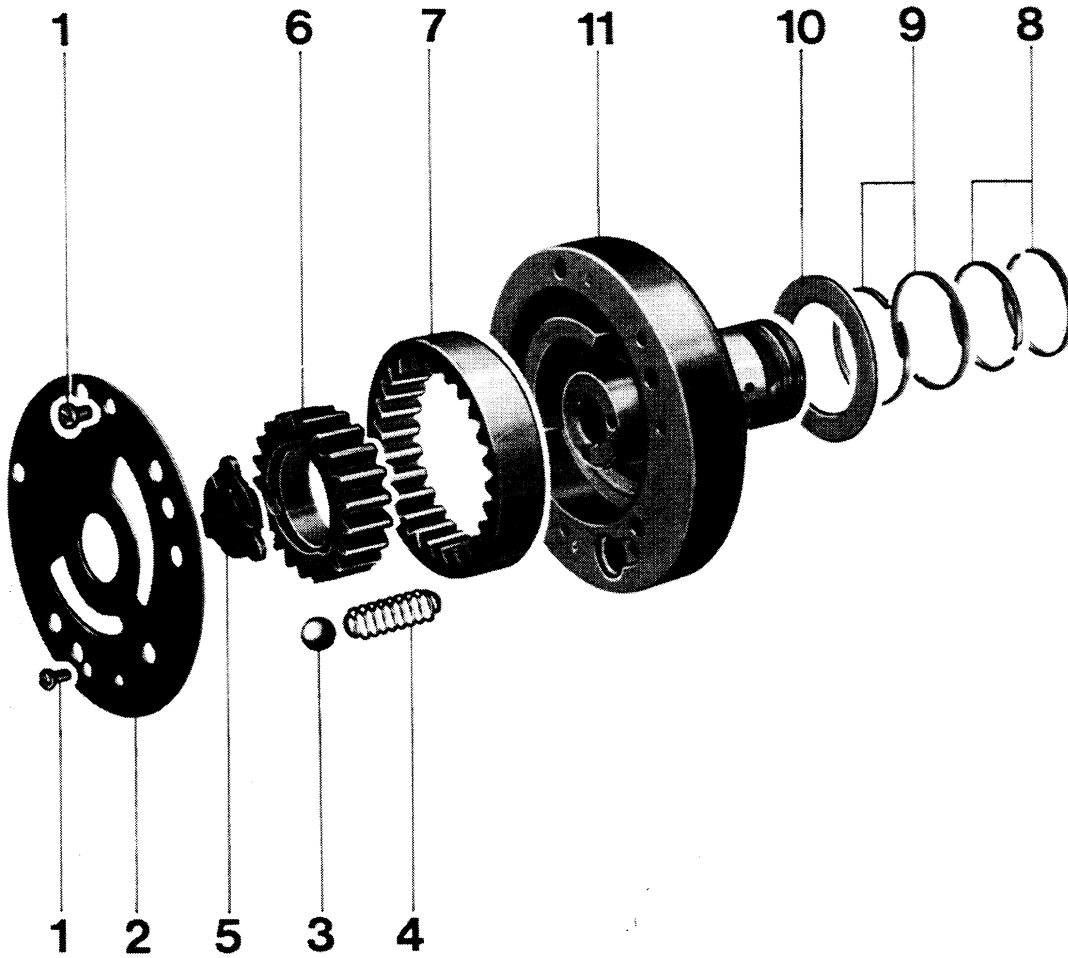

| No. | Description           | Qty. | Note When:   |   | Special Instructions |
|-----|-----------------------|------|--|---|----------------------|
|     |                       |      | Removing   | Installing  |                      |
| 1   | Screw                 | 2    | Valve springs push against cover                             | Torque:<br>1.4 Nm (1 ft lb)   |                      |
| 2   | Cover                 | 1    |  | Check for scoring   |                      |
| 3   | Valve ball 11 mm dia. | 1    |  |   |                      |
| 4   | Valve spring          | 1    |  |   |                      |
| 5   | Drive dog             | 1    |  |   |                      |
| 6   | Inner gear            | 1    |  | Lubricate lightly with oil before installing                                    |                      |
| 7   | Outer gear            | 1    |  | Lubricate lightly with oil before installing.<br>Manufacturing codes face cover |                      |
| 8   | Piston ring (small)   | 2    | Ends are connected together; disconnect and remove carefully |   |                      |
| 9   | Piston ring (large)   | 2    | Ends are connected together; disconnect and remove carefully |   |                      |
| 10  | Thrust washer         | 1    | Remove after removing piston rings                           | Install before installing piston rings  |                      |
| 11  | Body                  | 1    |  |   |                      |

## ASSEMBLING OIL PUMP

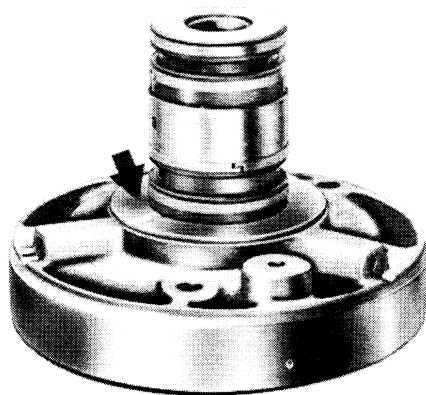

1. Place thrust washer (arrow) on pump neck and then install piston rings carefully.
2. Check movement of pump. It should be possible to turn it with the inserted pump shaft by hand without resistance.

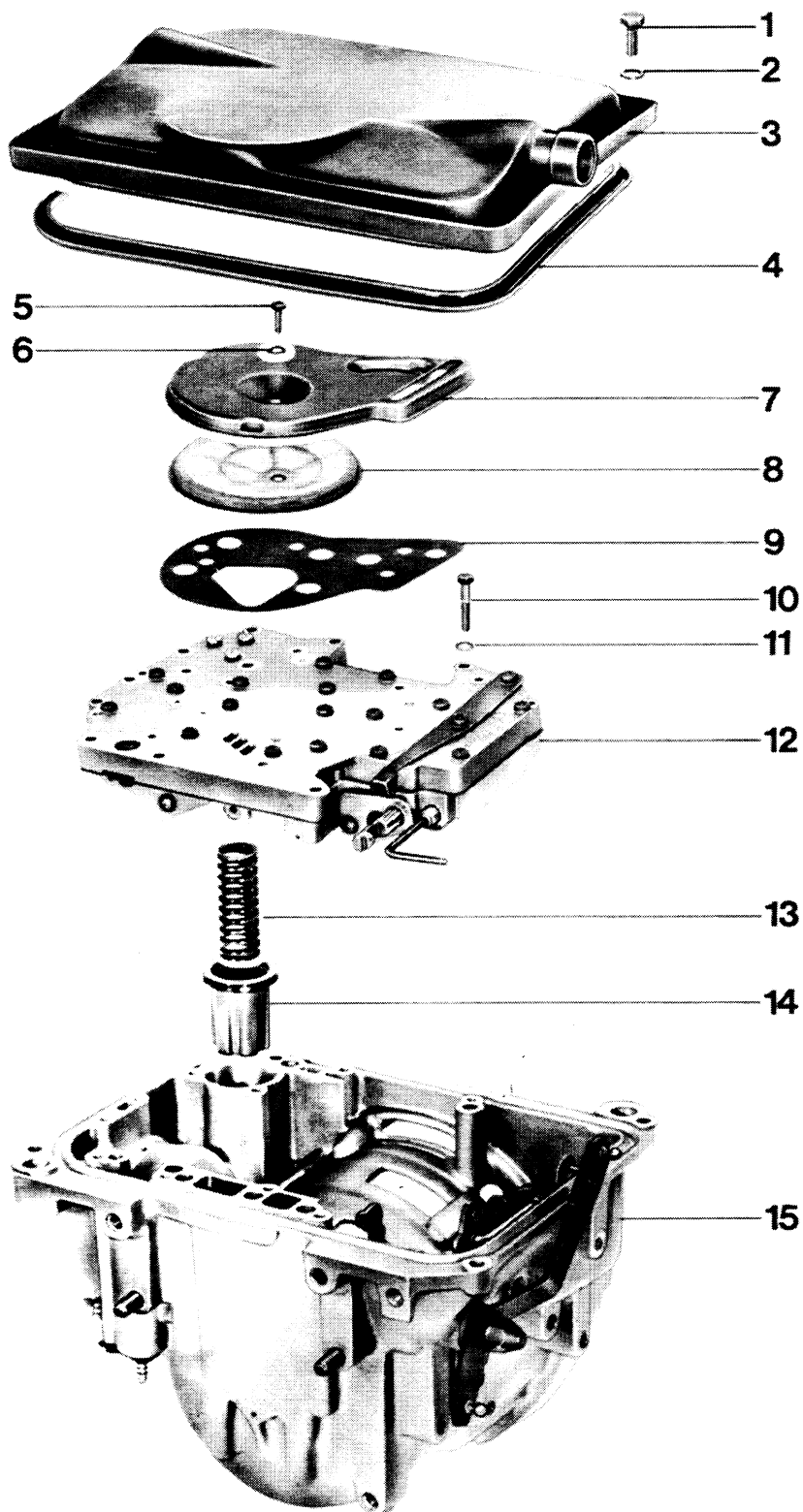

| No. | Description               | Qty. | Note When:                            |                               | Special Instructions |
|-----|---------------------------|------|---------------------------------------|-------------------------------|----------------------|
|     |                           |      | Removing                              | Installing                    |                      |
| 1   | Bolt                      | 4    |                                       | Torque:<br>20.6 Nm (15 ft lb) |                      |
| 2   | Lock washer               | 4    |                                       | Replace if necessary          |                      |
| 3   | Oil sump                  | 1    |                                       |                               |                      |
| 4   | Gasket                    | 1    |                                       | Replace                       |                      |
| 5   | Screw                     | 2    |                                       | Torque:<br>3.5 Nm (2.5 ft lb) |                      |
| 6   | Spring washer             | 2    |                                       |                               |                      |
| 7   | Cover                     | 1    |                                       |                               |                      |
| 8   | Oil filter screen         | 1    |                                       |                               |                      |
| 9   | Gasket                    | 1    |                                       | Replace                       |                      |
| 10  | Bolt                      | 11   | Unscrew bolt shown<br>in drawing last | Torque:<br>3.5 Nm (2.5 ft lb) |                      |
| 11  | Spring washer             | 11   |                                       |                               |                      |
| 12  | Valve body                | 1    |                                       |                               |                      |
| 13  | Spring for accumulator    | 1    |                                       |                               |                      |
| 14  | Piston for<br>accumulator | 1    |                                       |                               |                      |

## REMOVING AND INSTALLING VALVE BODY

## Removing

2. Tighten bolts alternately to torque of 3.5 Nm (2.5 ft lb).

## Note :

The valve body can be removed from a transmission installed in the car.

## Note :

Never run engine or have car towed when transmission oil sump has been removed or oil drained.

## Installing

1. Connect manual valve (arrow A) and kickdown valve (arrow B).

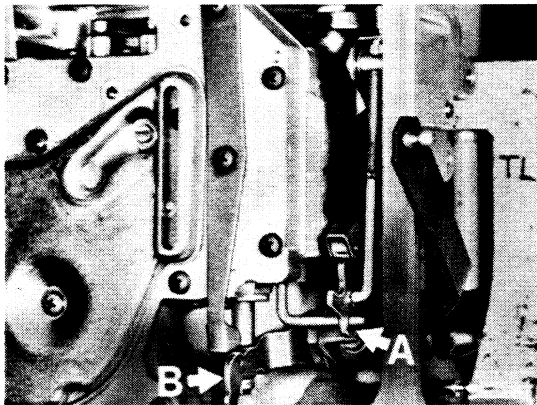

## FROM 1983 MODEL ON

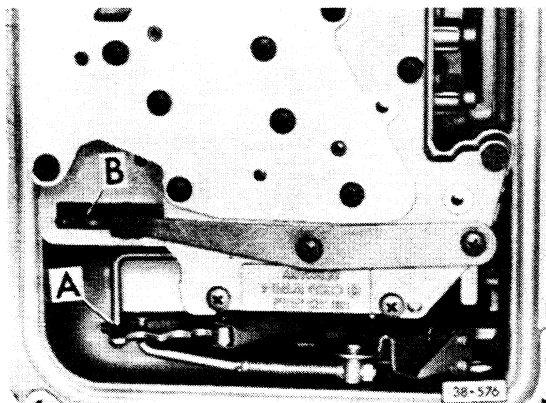

REMOVING AND INSTALLING TRANSFER AND SEPARATION PLATE  
(FROM 1983 MODEL ON)

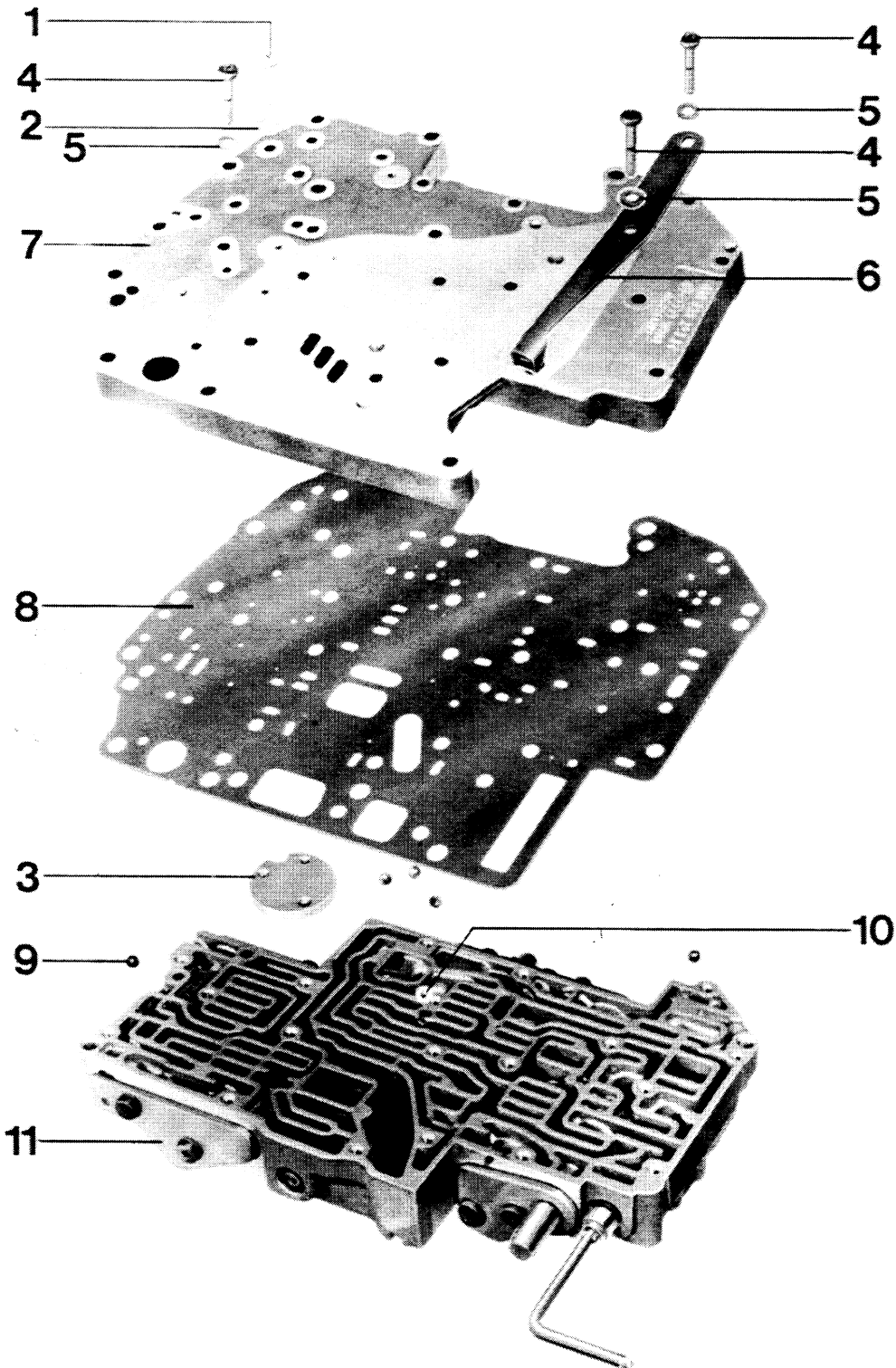

| No. | Description                   | Qty. | Note When: |   | Special Instructions |
|-----|-------------------------------|------|------------|---|----------------------|
|     |                               |      | Removing   | Installing  |                      |
| 1   | Oval head screw               | 3    |            | Torque:<br>3.5 Nm (2.5 ft lb)                     |                      |
| 2   | Washer                        | 3    |            | Replace if necessary                              |                      |
| 3   | Support plate for accumulator | 1    |            |   |                      |
| 4   | Oval head screw               | 19   |            | Tighten uniformly to torque of 3.5 Nm (2.5 ft lb) |                      |
| 5   | Washer                        | 19   |            | Replace if necessary                              |                      |
| 6   | Shift segment spring          | 1    |            |   |                      |
| 7   | Transfer plate                | 1    |            | Note marks  |                      |
| 8   | Separation plate              | 1    |            | Note marks  |                      |
| 9   | Ball (6 mm dia.)              | 5    |            | Note arrangement                                  |                      |
| 10  | Ball (3 mm dia.)              | 1    |            | Note arrangement                                  |                      |
| 11  | Valve body                    | 1    |            | Note marks  |                      |

REMOVING AND INSTALLING TRANSFER AND SEPARATION PLATES

1. Identification of transfer plate:

Part No. 010.325.283 J cast in part (arrow).

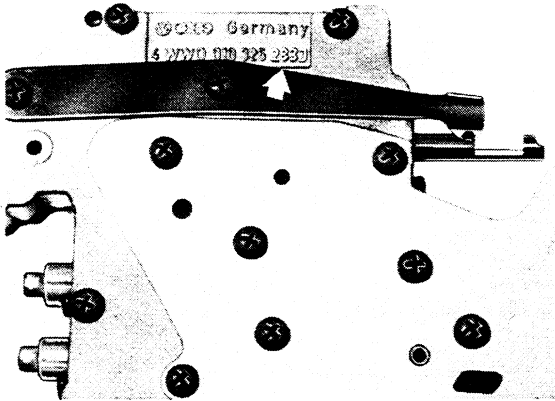

3. Identification of separation plate:

Transmission types RCA, RCB and RCF

- Arrow 1 = 2 notches
- Arrow 2 = 3 notches
- Arrow 3 = 1 notch

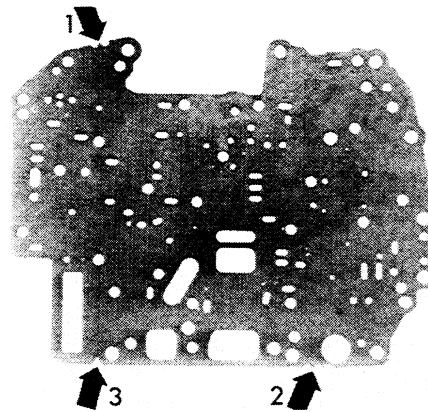

2. Identification of separation plate:

Transmission type RH  
 Arrow 1 = 3 notches  
 Arrow 2 = 2 notches

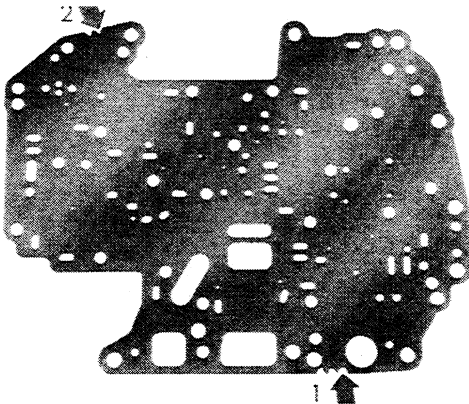

4. Identification of separation plate:

Transmission types RCD and RCE  
 Arrow 1 = 2 notches  
 Arrow 2 = 4 notches  
 Arrow 3 = 1 notch

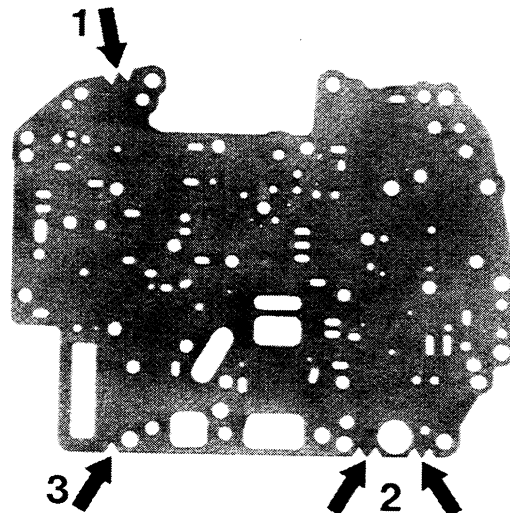



5. Arrangement of valve balls in valve body:

5 balls of 6 mm dia.  
1 ball of 3 mm dia. (arrow A)

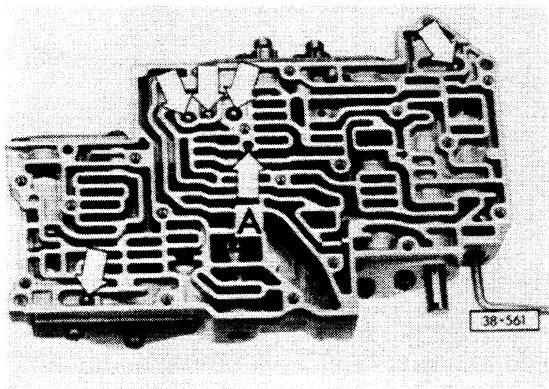

6. Identification of valve body up to December 83:

BB = Transmission RH  
FB = Transmissions RCA and RCB

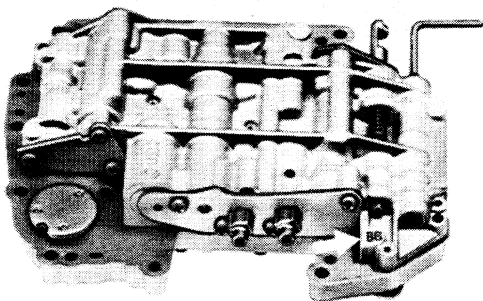

7. Identification of valve body as from December 83:

FMP = Transmission RCD and RCE  
FBP = Transmission RCF

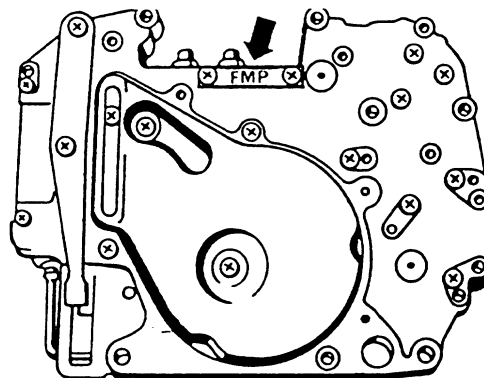

Identification is by means of a coding vane (arrow), screwed on to the transfer plate.

#### Note

The coding vane must remain pointing to valve body during repair.

Parts must be removed from a valve body to clean a very dirty valve body. These parts should be placed in a special tray to guarantee re-installation in original position. Outside shape of tray matches that of valve body to facilitate insertion of valves and springs.

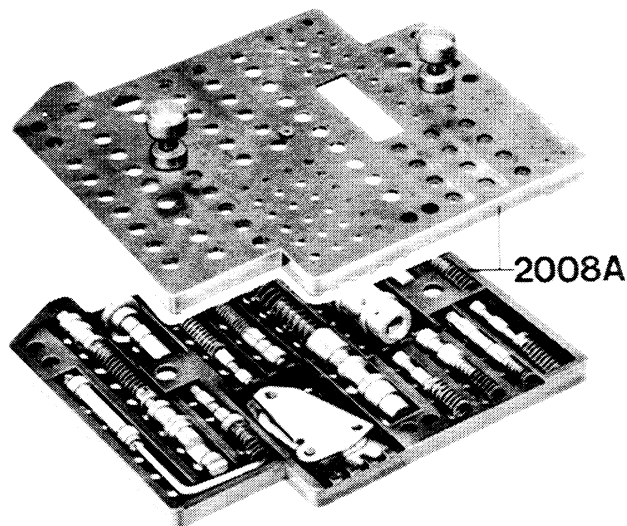

#### Disassembling

Normally, valve body is only disassembled when transmission damage is from burnt friction linings or ATF is excessively dirty. As long as ATF is relatively clean, in most cases it will be sufficient to flush assembled valve body in clean cleaning fluid. Then dry with compressed air.

1. Remove end plates on one side, remove valves and springs one after the other and place them in tray.
2. Unscrew end plates on other side and remove springs and valves one after the other, also placing them in tray.
3. Place cover on tray.

#### Note :

Slight scoring on valves will not cause operating problems. They can be used again.

4. Agitate tray with parts in cleaning fluid and then dry with compressed air. Never use water.

#### Assembling

1. Assembling must be done at a clean working place. Never use fluffy rags when cleaning and assembling.
2. Valves and springs must be installed in their original bores of valve body.
3. First install springs and valves in one side, install end plates, then install valves and springs of other side and bolt end plates.

#### Note :

Coat all valves with ATF and check for free movement. Valves must slide down bores by their own weight.

DISASSEMBLING AND ASSEMBLING VALVE BODY

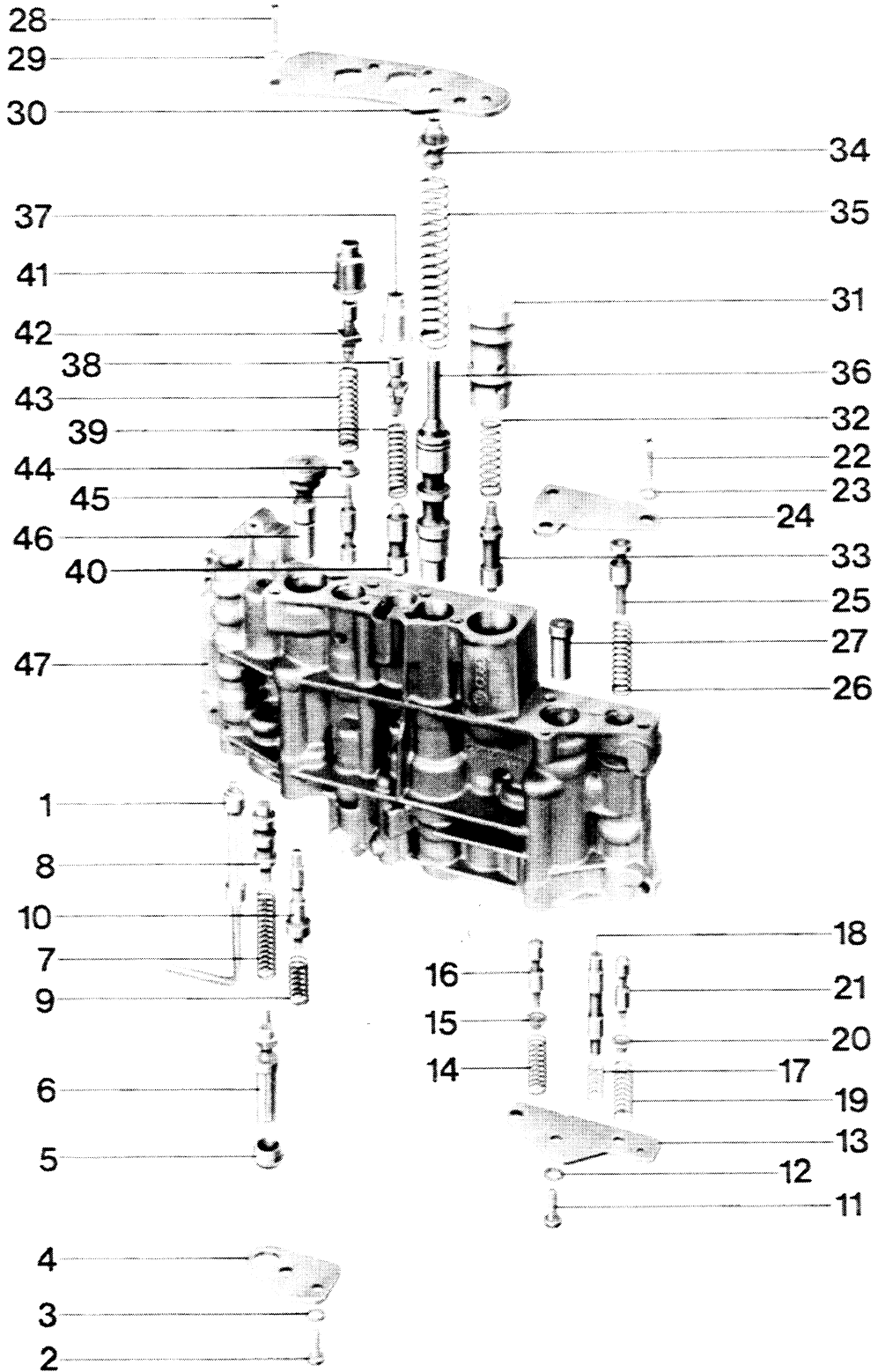

| No. | Description                            | Qty. | Note When: |  | Special Instructions |
|-----|--|------|------------|--|----------------------|
|     |  |      | Removing   | Installing   |                      |
| 1   | Manual valve                           | 1    |            |  |                      |
| 2   | Screw                                  | 2    |            | Torque:<br>3.5 Nm (2.5 ft lb)                                      |                      |
| 3   | Washer                                 | 2    |            | Replace if necessary   |                      |
| 4   | End plate                              | 1    |            |  |                      |
| 5   | Guide sleeve for<br>kickdown valve     | 1    |            |  |                      |
| 6   | Kickdown valve                         | 1    |            |  |                      |
| 7   | Throttle pressure<br>valve spring      | 1    |            |  |                      |
| 8   | Throttle pressure<br>valve             | 1    |            |  |                      |
| 9   | Shift valve<br>1 – 2 spring            | 1    |            | Same size as spring for<br>shift valve 2 – 3, but<br>do not mix up |                      |
| 10  | Shift valve 1 – 2                      | 1    |            |  |                      |
| 11  | Screw                                  | 2    |            | Torque:<br>3.5 Nm (2.5 ft lb)                                      |                      |
| 12  | Washer                                 | 2    |            | Replace if necessary   |                      |
| 13  | End plate                              | 1    |            |  |                      |
| 14  | Converter pressure<br>valve spring     | 1    |            |  |                      |
| 15  | Spring retainer                        | 1    |            |  |                      |
| 16  | Converter pressure<br>valve            | 1    |            |  |                      |
| 17  | Shift valve<br>2 – 3 spring            | 1    |            | Same size as spring for<br>shift valve 1 – 2, but<br>do not mix up |                      |
| 18  | Shift valve 2 – 3                      | 1    |            |  |                      |
| 19  | 3 – 2 kickdown<br>control valve spring | 1    |            |  |                      |
| 20  | Spring retainer                        | 1    |            |  |                      |
| 21  | 3 - 2 kickdown<br>control valve        | 1    |            |  |                      |

| No. | Description                                     | Qty. | Note When: |   | Special Instructions |
|-----|---|------|------------|---|----------------------|
|     |   |      | Removing   | Installing  |                      |
| 22  | Screw   | 3    |            | Torque:<br>3.5 Nm (2.5 ft lb)                         |                      |
| 23  | Washer  | 3    |            | Replace if necessary                                  |                      |
| 24  | End plate                                       | 1    |            |   |                      |
| 25  | Control valve 3 – 2                             | 1    |            |   |                      |
| 26  | Control valve 3 – 2<br>spring                   | 1    |            |   |                      |
| 27  | Governor plug 2 – 3                             | 1    |            |   |                      |
| 28  | Screw   | 4    |            | Torque:<br>3.5 Nm (2.5 ft lb)                         |                      |
| 29  | Washer  | 4    |            | Replace if necessary                                  |                      |
| 30  | End plate                                       | 1    |            |   |                      |
| 31  | Apply valve bushing                             | 1    |            |   |                      |
| 32  | Apply valve spring                              | 1    |            |   |                      |
| 33  | Apply valve 1st and<br>reverse gear brake       | 1    |            |   |                      |
| 34  | Main pressure valve<br>adjusting screw          | 1    |            | Do not turn, can only<br>be adjusted on test<br>stand |                      |
| 35  | Main pressure valve<br>spring                   | 1    |            |   |                      |
| 36  | Main pressure valve                             | 1    |            |   |                      |
| 37  | Sleeve  | 1    |            |   |                      |
| 38  | Main pressure limiting<br>valve adjusting screw | 1    |            | Do not turn, can only<br>be adjusted on test<br>stand |                      |
| 39  | Main pressure limiting<br>valve spring          | 1    |            |   |                      |
| 40  | Main pressure limiting<br>valve                 | 1    |            |   |                      |
| 41  | Sleeve  | 1    |            |   |                      |

| No. | Description                                      | Qty. | Note When: |   | Special Instructions |
|-----|--|------|------------|---|----------------------|
|     |  |      | Removing   | Installing                                      |                      |
| 42  | Throttle pressure limiting valve adjusting screw | 1    |            | Do not turn, can only be adjusted on test stand |                      |
| 43  | Throttle pressure limiting valve spring          | 1    |            |   |                      |
| 44  | Spring retainer                                  | 1    |            |   |                      |
| 45  | Throttle pressure limiting valve                 | 1    |            |   |                      |
| 46  | Governor plug 1 – 2                              | 1    |            |   |                      |
| 47  | Body   | 1    |            | Note marks                                      |                      |

DISASSEMBLING AND ASSEMBLING VALVE BODY (RCD AND RCE TRANSMISSIONS)

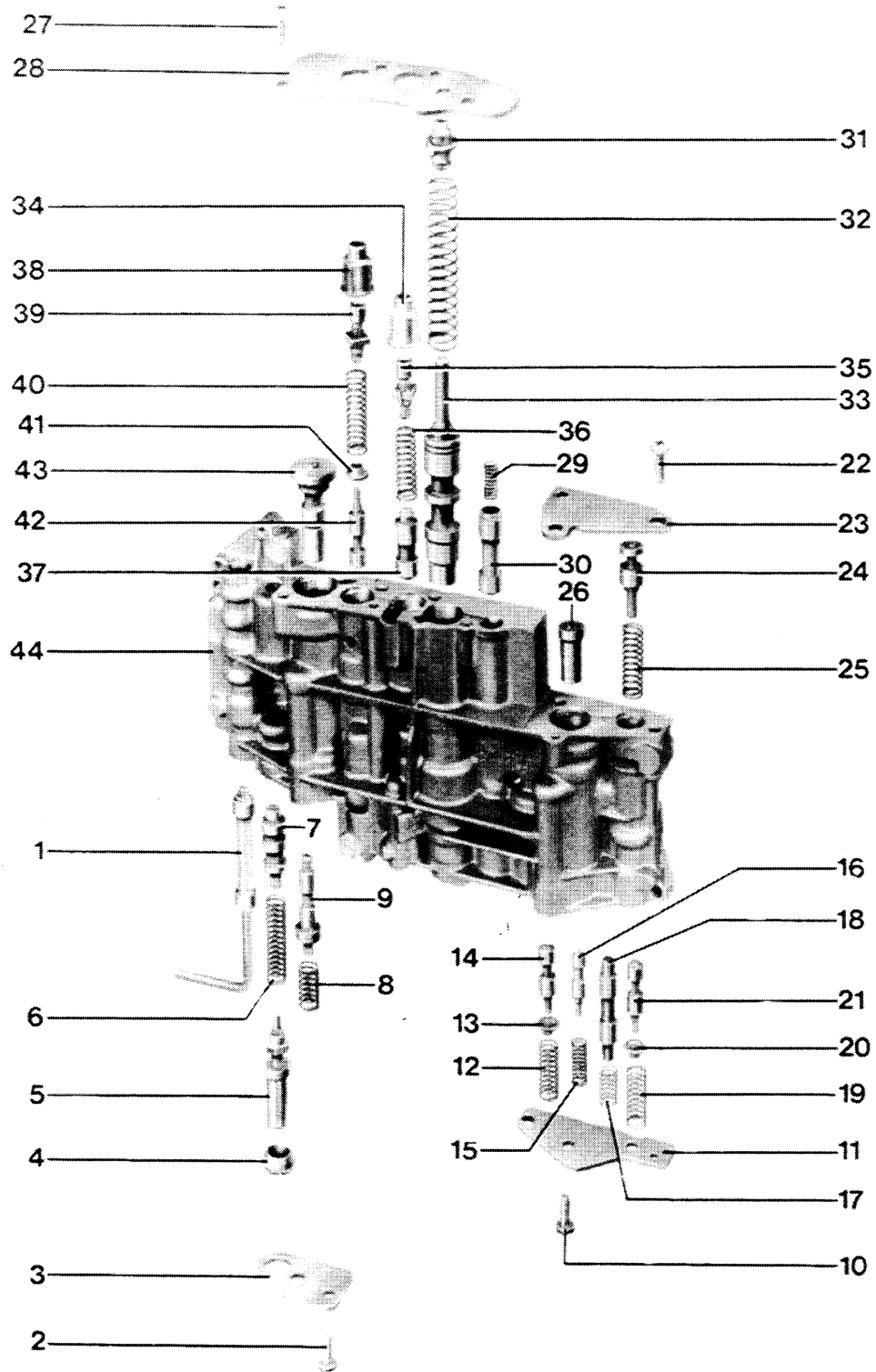

| No. | Description                     | Qty. | Note when: |  |
|-----|---------------------------------|------|------------|--|
|     |                                 |      | Removing   | Installing   |
| 1   | Manual valve                    | 1    |            |  |
| 2   | Screw                           | 2    |            | Torque: 3.5 Nm   |
| 3   | End plate                       | 1    |            |  |
| 4   | Guide sleeve for kickdown valve | 1    |            |  |
| 5   | Kickdown valve                  | 1    |            |  |
| 6   | Throttle pressure valve spring  | 1    |            |  |
| 7   | Throttle pressure valve         | 1    |            |  |
| 8   | Shift valve spring              | 1    | 1 - 2      | Same size as spring for shift valve 2-3, but do not mix up |
| 9   | Shift valve                     | 1    | 1 - 2      |  |
| 10  | Screw                           | 2    |            | Torque: 3.5 Nm   |
| 11  | End plate                       | 1    |            |  |
| 12  | Converter pressure valve spring | 1    |            |  |
| 13  | Spring retainer                 | 1    |            |  |
| 14  | Converter pressure valve        | 1    |            |  |
| 15  | Step pressure valve spring      | 1    |            |  |
| 16  | Step pressure valve             | 1    |            |  |
| 17  | Shift valve spring              | 1    | 2 - 3      | Same size as spring for shift valve 1-2, but do not mix up |



| No. | Description                            | Qty. | Note when: |   |
|-----|--|------|------------|---|
|     |  |      | Removing   | Installing                                      |
| 18  | Shift valve                            | 1    | 2 - 3      |   |
| 19  | 3 - 2 kickdown control valve spring    | 1    |            |   |
| 20  | Spring retainer                        | 1    |            |   |
| 21  | 3 - 2 kickdown control valve           | 1    |            |   |
| 22  | Screw                                  | 3    |            | Torque: 3-5 Nm                                  |
| 23  | End plate                              | 1    |            |   |
| 24  | Control valve 3 - 2                    | 1    |            |   |
| 25  | Control valve 3 - 2 spring             | 1    |            |   |
| 26  | Governor plug 2 - 3                    | 1    |            |   |
| 27  | Screw                                  | 4    |            | Torque: 3.5 Nm                                  |
| 28  | End plate                              | 1    |            |   |
| 29  | Apply valve spring                     | 1    |            |   |
| 30  | Apply valve 1st and reverse gear brake | 1    |            |   |
| 31  | Main pressure valve adjusting screw    | 1    |            | Do not turn, can only be adjusted on test stand |
| 32  | Main pressure valve spring             | 1    |            |   |
| 33  | Main pressure valve                    | 1    |            |   |

| No. | Description                                      | Qty. | Note when: |   |
|-----|--|------|------------|---|
|     |  |      | Removing   | Installing                                      |
| 34  | Sleeve   | 1    |            |   |
| 35  | Main pressure limiting valve adjusting screw     | 1    |            | Do not turn, can only be adjusted on test stand |
| 36  | Main pressure limiting valve spring              | 1    |            |   |
| 37  | Main pressure limiting valve                     | 1    |            |   |
| 38  | Sleeve   | 1    |            |   |
| 39  | Throttle pressure limiting valve adjusting screw | 1    |            | Do not turn, can only be adjusted on test stand |
| 40  | Throttle pressure limiting valve spring          | 1    |            |   |
| 41  | Spring retainer                                  | 1    |            |   |
| 42  | Throttle pressure limiting valve                 | 1    |            |   |
| 43  | Governor plug<br>1 - 2                           | 1    |            |   |
| 44  | Body   | 1    |            | Note marks                                      |

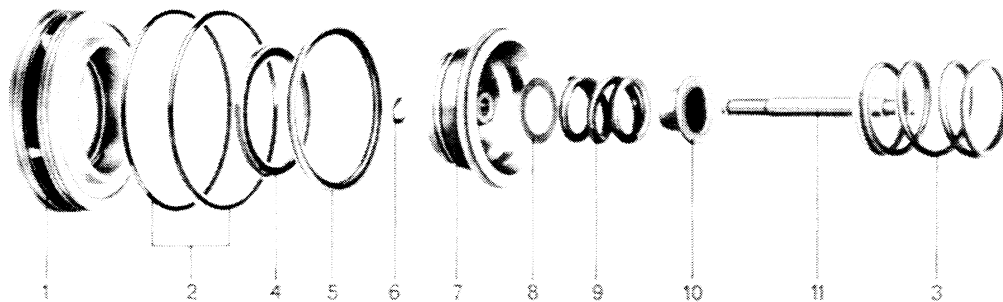

| No. | Description        | Qty. | Removing | Note When:<br>Installing  | Special<br>Instructions |
|-----|--------------------|------|----------|---|-------------------------|
| 1   | Cover              | 1    |          |   |                         |
| 2   | Seal               | 2    |          | Replace   |                         |
| 3   | Return spring      | 1    |          |   |                         |
| 4   | Seal               | 1    |          | Sealing lip faces cover   |                         |
| 5   | Seal               | 1    |          | Sealing lip faces<br>piston rod   |                         |
| 6   | Circlip            | 1    |          |   |                         |
| 7   | Modulator piston   | 1    |          | Only pre-assembled and<br>adjusted replacement<br>parts available (con-<br>sists of parts 6 – 11) |                         |
| 8   | Shim               | X    |          |   |                         |
| 9   | Accumulator spring | 1    |          |   |                         |
| 10  | Spring retainer    | 1    |          |   |                         |
| 11  | Piston rod         | 1    |          |   |                         |

ASSEMBLING 2ND GEAR BRAKE

Position oil seals correctly.  
Distance "a" = 96.5 mm.

Piston with riveted piston rod must only be installed with recessed cover.

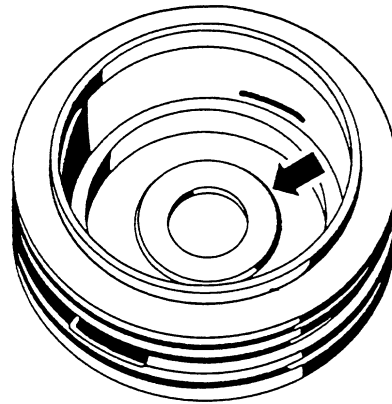
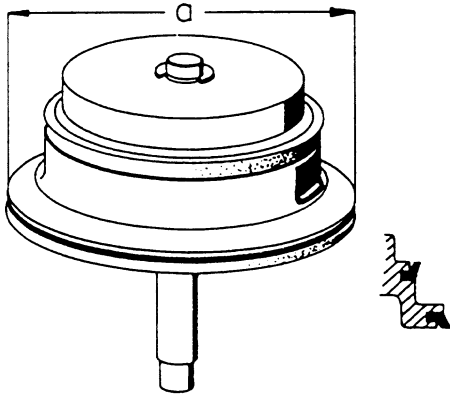

Cover is recessed (arrow). This provides piston disk with enough play.

Note

Securing the piston rod to the piston has been changed.  
Previously: Circlip  
Changed: Riveted on to piston with disk (arrow)

Pay attention to piston rod length.

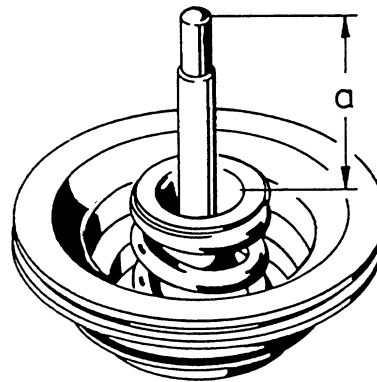
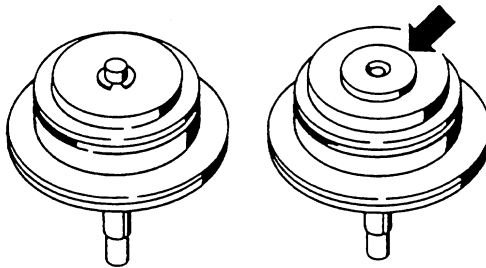

|                          | Distance "a"            |
|--------------------------|-------------------------|
| D+R clutch with 134 mm Ø | 61,9 <sub>-0,5</sub> mm |
| D+R clutch with 140 mm Ø | 52,4 <sub>-0,5</sub> mm |

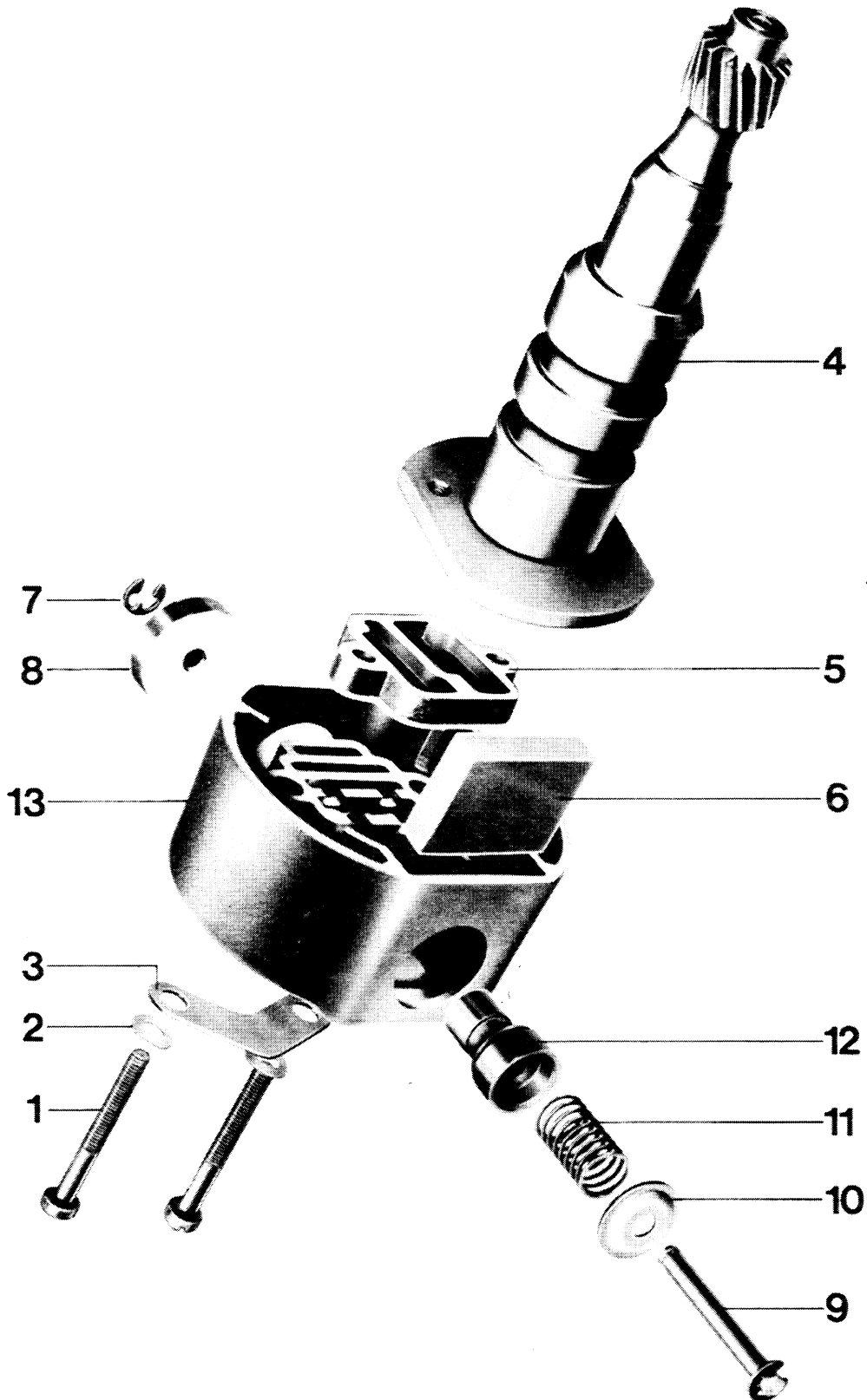

| No. | Description        | Qty. | Note When: |  | Special Instructions |
|-----|--------------------|------|------------|--|----------------------|
|     |                    |      | Removing   | Installing   |                      |
| 1   | Screw              | 2    |            | Torque:<br>3.5 Nm (2.5 ft lb)  |                      |
| 2   | Washer             | 2    |            | Replace if necessary   |                      |
| 3   | Thrust plate       | 1    |            | Check for wear   |                      |
| 4   | Governor shaft     | 1    |            | Can be replaced<br>separately  |                      |
| 5   | Transfer plate     | 1    |            | Position correctly   |                      |
| 6   | Balance weight     | 1    |            | Balanced with governor;<br>do not mix up with<br>weight from a different<br>governor |                      |
| 7   | Circlip            | 1    |            |  |                      |
| 8   | Centrifugal weight | 1    |            |  |                      |
| 9   | Pull rod           | 1    |            |  |                      |
| 10  | Spring retainer    | 1    |            |  |                      |
| 11  | Spring             | 1    |            |  |                      |
| 12  | Valve              | 1    |            |  |                      |
| 13  | Body               | 1    |            |  |                      |

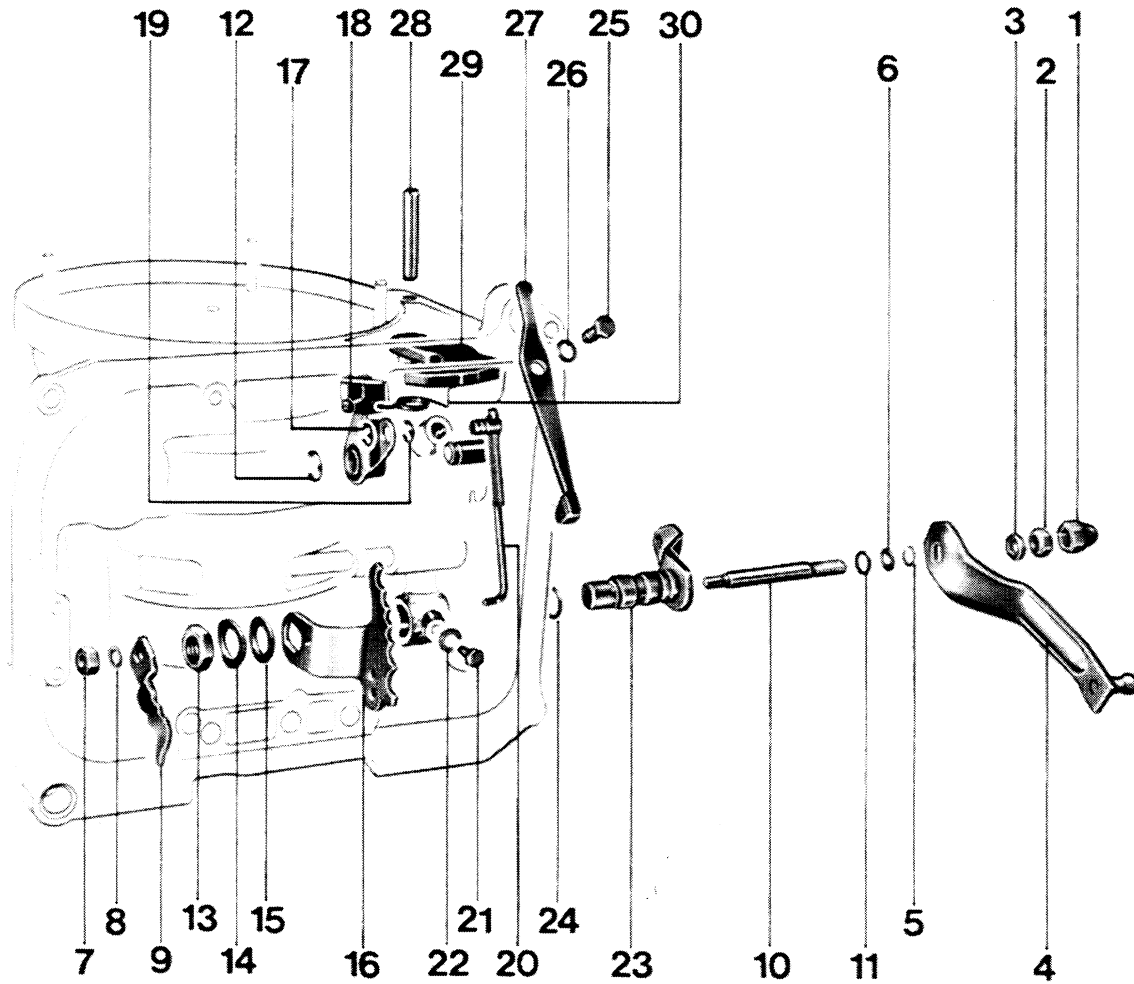

| No. | Description            | Qty. | Note When: |                                    | Special Instructions |
|-----|------------------------|------|------------|------------------------------------|----------------------|
|     |                        |      | Removing   | Installing                         |                      |
| 1   | Cap                    | 1    |            |                                    |                      |
| 2   | Nut                    | 1    |            | Torque:<br>20 Nm (14 ft lb)        |                      |
| 3   | Spacer                 | 1    |            |                                    |                      |
| 4   | Lever                  | 1    |            |                                    |                      |
| 5   | Circlip                | 1    |            |                                    |                      |
| 6   | Thrust washer          | 1    |            |                                    |                      |
| 7   | Nut                    | 1    |            | Torque:<br>17 Nm (12 ft lb)        |                      |
| 8   | Washer                 | 1    |            |                                    |                      |
| 9   | Kickdown valve lever * | 1    |            | Position correctly                 |                      |
| 10  | Shaft                  | 1    |            |                                    |                      |
| 11  | Seal                   | 1    |            | Coat with ATF                      |                      |
| 12  | Lock washer            | 1    |            |                                    |                      |
| 13  | Nut                    | 1    |            | Torque:<br>20.5 Nm (15 ft lb)      |                      |
| 14  | Washer                 | 1    |            |                                    |                      |
| 15  | Stop washer            | 1    |            |                                    |                      |
| 16  | Ratchet                | 1    |            | Check detent notches<br>for wear   |                      |
| 17  | Lock washer            | 1    |            |                                    |                      |
| 18  | Engaging lever         | 1    |            | Check rollers for easy<br>movement |                      |
| 19  | Lock washer            | 1    |            |                                    |                      |
| 20  | Operating rod          | 1    |            |                                    |                      |
| 21  | Bolt                   | 1    |            | Torque:<br>3.5 Nm (2.5 ft lb)      |                      |
| 22  | Washer                 | 1    |            |                                    |                      |



| No. | Description | Qty. | Note When:                      |                               | Special Instructions |
|-----|-------------|------|---------------------------------|-------------------------------|----------------------|
|     |             |      | Removing                        | Installing                    |                      |
| 23  | Lever       | 1    |                                 |                               |                      |
| 24  | Seal        | 1    |                                 | Coat with ATF                 |                      |
| 25  | Bolt        | 1    |                                 | Torque:<br>20.5 Nm (15 ft lb) |                      |
| 26  | Lock washer | 1    |                                 |                               |                      |
| 27  | Spring      | 1    |                                 |                               |                      |
| 28  | Bolt        | 1    | Drive out with right size punch |                               |                      |
| 29  | Pawl        | 1    |                                 | Check for wear                |                      |
| 30  | Spring      | 1    |                                 | Position correctly            |                      |

\* Operating lever for kickdown valve is flat on stop surface A as from 1983 model.

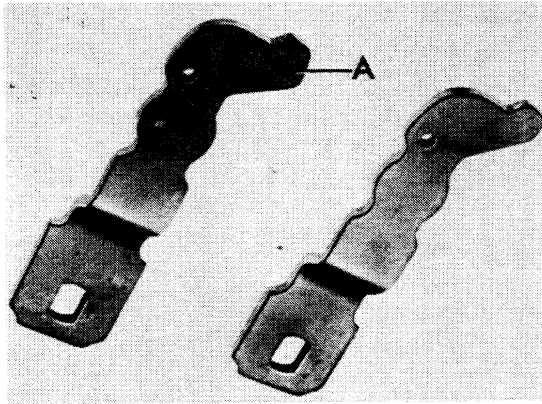

**Note :**

New operating lever can also be installed in old transmission.

Old operating lever, however, may not be installed in transmission with new kickdown valve.

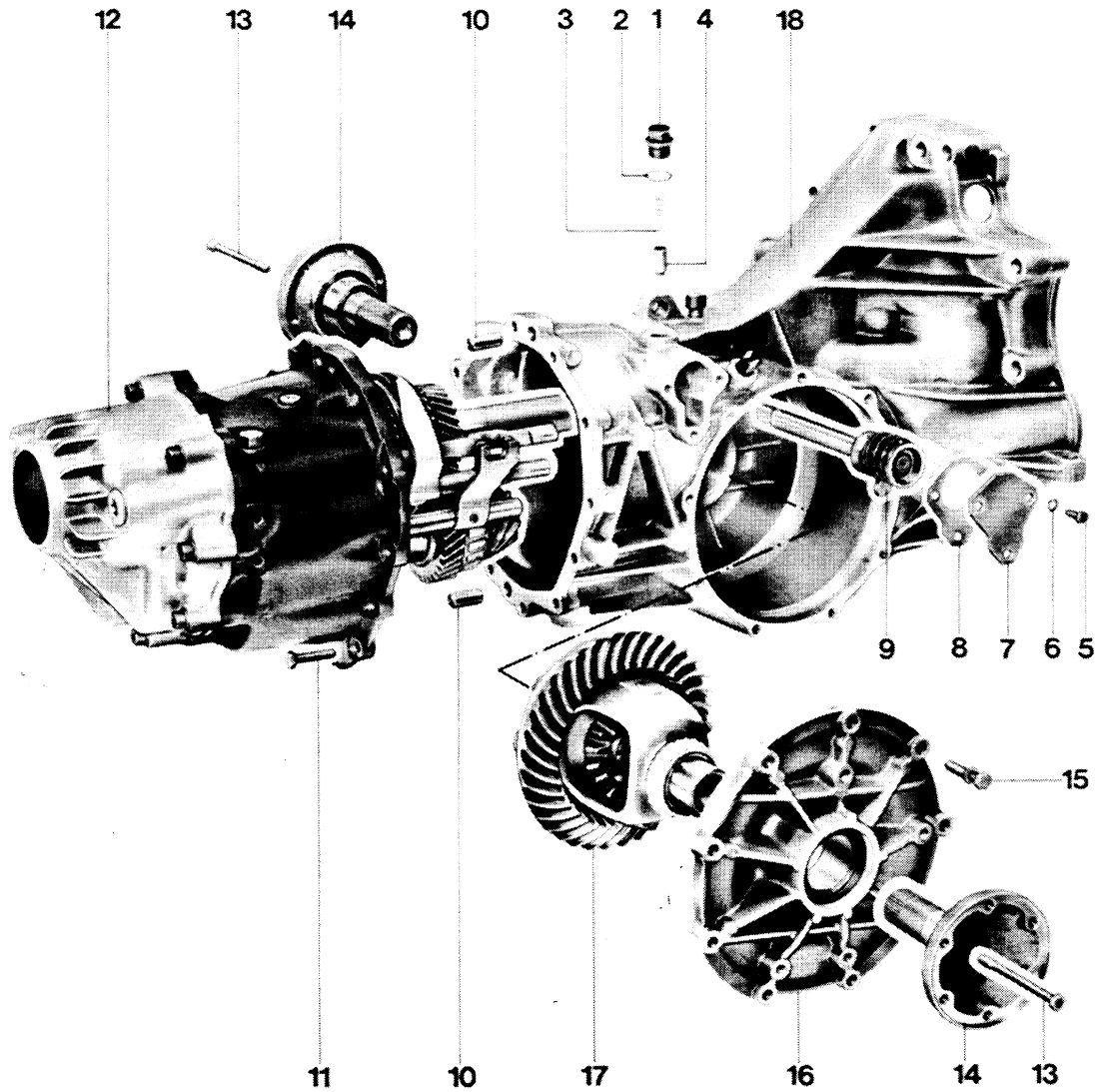

| No. | Description             | Qty. | Note When:                     |  | Special Instructions |
|-----|-------------------------|------|--------------------------------|--|----------------------|
|     |                         |      | Removing                       | Installing   |                      |
| 1   | Threaded sleeve         | 1    |                                | Torque: 30 Nm<br>(22 ft lb)                                      |                      |
| 2   | Gasket                  | 1    |                                |  |                      |
| 3   | Spring                  | 1    |                                |  |                      |
| 4   | Sleeve                  | 1    |                                |  |                      |
| 5   | Bolt                    | 3    |                                | Torque: 6 to 10 Nm<br>(4 to 7 ft lb)                             |                      |
| 6   | Washer                  | 3    |                                |  |                      |
| 7   | Cover                   | 1    |                                |  |                      |
| 8   | Gasket                  | 1    |                                | Replace  |                      |
| 9   | Selector shaft assembly | 1    |                                |  |                      |
| 10  | Dowel sleeve            | 2    |                                |  |                      |
| 11  | Bolt                    | 12   |                                | Torque: 24 Nm<br>(17 ft lb)                                      |                      |
| 12  | Gear carrier assembly   | 1    |                                | Coat sealing surface with original VW sealing compound D 3       |                      |
| 13  | Bolt                    | 2    |                                | Torque: 25 Nm<br>(18 ft lb)                                      |                      |
| 14  | Flange shaft            | 2    |                                |  |                      |
| 15  | Bolt with washer        | 9    |                                | Torque: 25 Nm<br>(18 ft lb)                                      |                      |
| 16  | Cover                   | 1    |                                | Position correctly, magnet faces down                            |                      |
| 17  | Differential            | 1    | Remove gearbox before removing | Light coat of oil for tapered roller bearings and pinion splines |                      |

| No. | Description | Qty. | Note When:   |            | Special Instructions |
|-----|-------------|------|--|------------|----------------------|
|     |             |      | Removing   | Installing |                      |
| 18  | Case        | 1    | If transmission case has to be replaced and deviation "r" is not given on ring gear, check position of pinion shaft prior to removing the gear carrier (actual distance) |            |                      |

## REMOVING AND INSTALLING DIFFERENTIAL

## Removing

## Note

Gear carrier must be removed first before removing the differential.

1. Unscrew flange shaft mounting bolt and take off flange shaft, while holding with a mandrel.

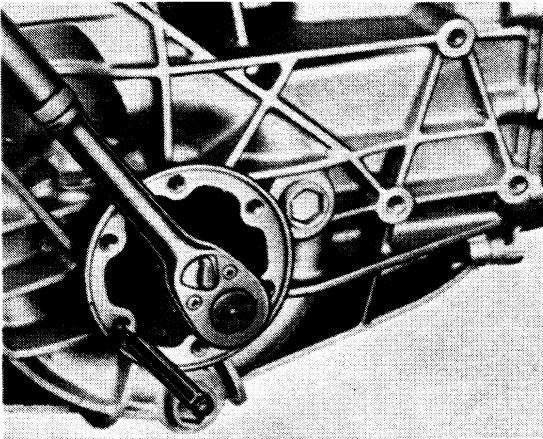

2. Unscrew final drive cover mounting bolts and pry off cover with two tire irons.

## Installing

1. Torque side transmission cover bolts to 25 Nm (18 ft lb).
2. Torque flange shaft mounting bolt to 25 Nm (18 ft lb).

## TOOLS

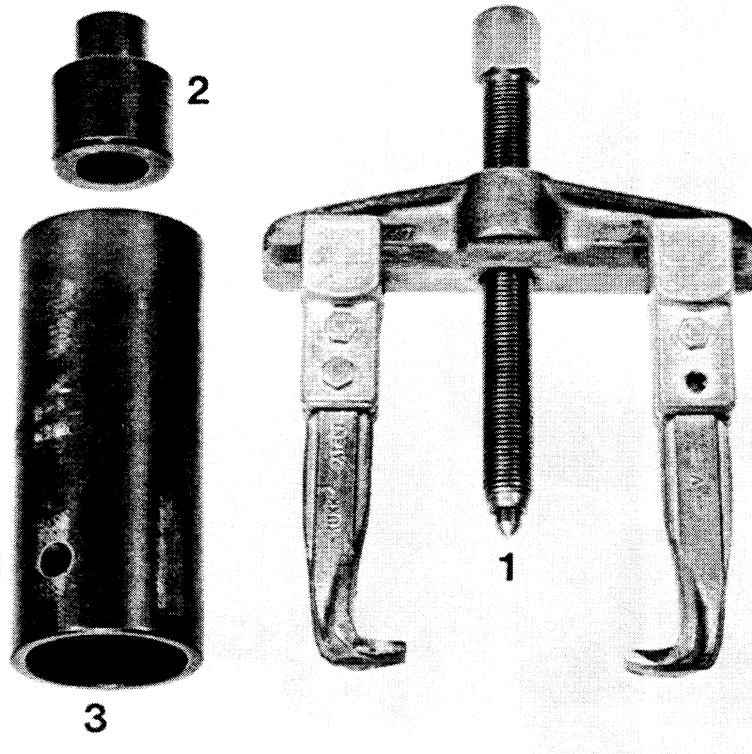

| No. | Description | Special Tool | Remarks                    |
|-----|-------------|--------------|----------------------------|
| 1   | Puller      | US 1078      | Standard, e. g. Kukko 44/2 |
| 2   | Thrust pad  | VW 295 a     |                            |
| 3   | Pipe        | VW 40 - 21   |                            |

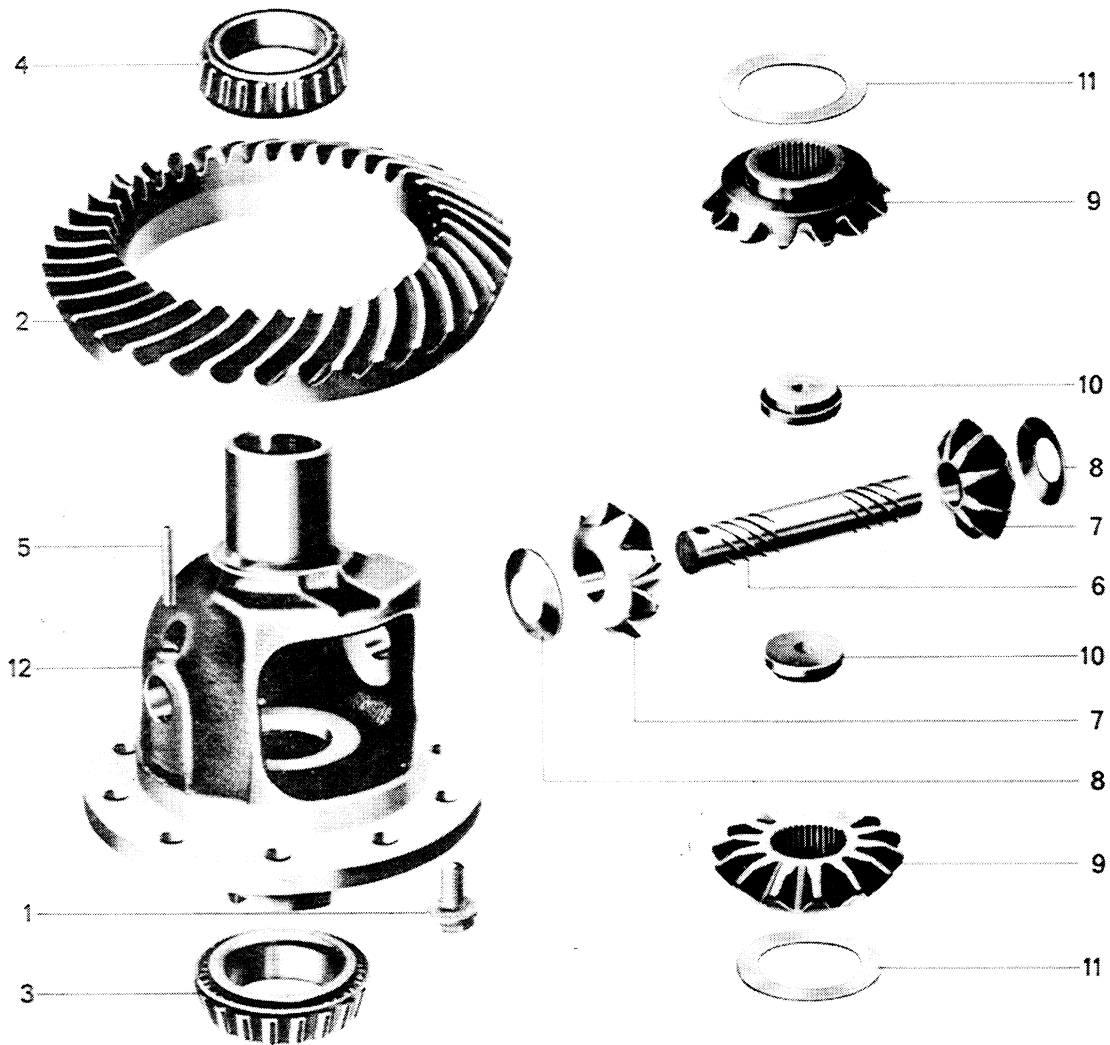

| No. | Description                                 | Qty. | Note When:                       |  | Special Instructions |
|-----|---|------|----------------------------------|--|----------------------|
|     |   |      | Removing                         | Installing   |                      |
| 1   | Bolt  | 10   |                                  | Loosen, then tighten cross-wise to 85 . . . 100 Nm (61 to 72 ft lb)          |                      |
| 2   | Ring gear                                   | 1    |                                  | Paired with pinion shaft   |                      |
| 3   | Inner race for large tapered roller bearing | 1    |                                  |  |                      |
| 4   | Inner race for small tapered roller bearing | 1    |                                  |  |                      |
| 5   | Dowel sleeve                                | 1    |                                  | Drive in flush   |                      |
| 6   | Shaft                                       | 1    | Drive in with a suitable mandrel | Drive in carefully to avoid damage on thrust washers. Lock with dowel sleeve |                      |
| 7   | Small differential gear                     | 2    |                                  |  |                      |
| 8   | Thrust washer                               | 2    |                                  | Check for wear   |                      |
| 9   | Large differential gear                     | 2    |                                  |  |                      |
| 10  | Nut for flange shaft                        | 2    |                                  |  |                      |
| 11  | Shim  | 2    |                                  | Determine new thickness  |                      |
| 12  | Differential housing                        | 1    |                                  | Adjust ring gear after replacing   |                      |



## DISASSEMBLING AND ASSEMBLING DIFFERENTIAL

## Disassembling

1. Clamp differential in a vise fitted with soft jaws and unscrew ring gear bolts.

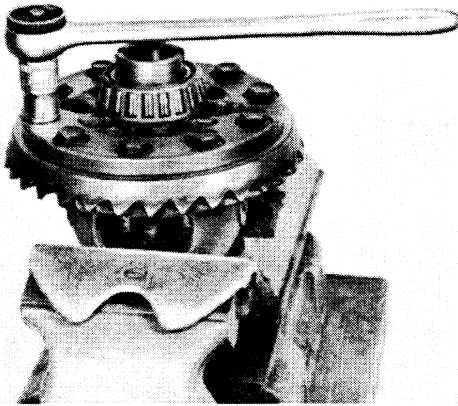

2. Drive ring gear off of housing.



3. Pull off inner races for large and small tapered roller bearings. Use US 1078 or a standard extractor (e. g. Kukko 44/2) and Special Tool VW 295 a.

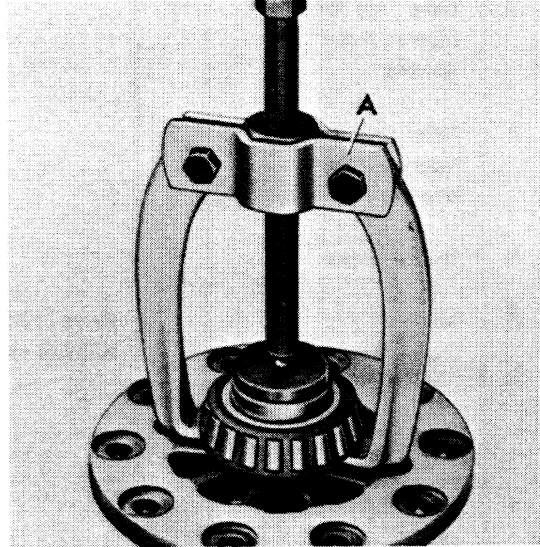

## Assembling

1. Heat inner races for small and large tapered roller bearings to about 100 °C (210 °F). Install on differential and press on to correct position. Use Special Tool VW 40 - 21.

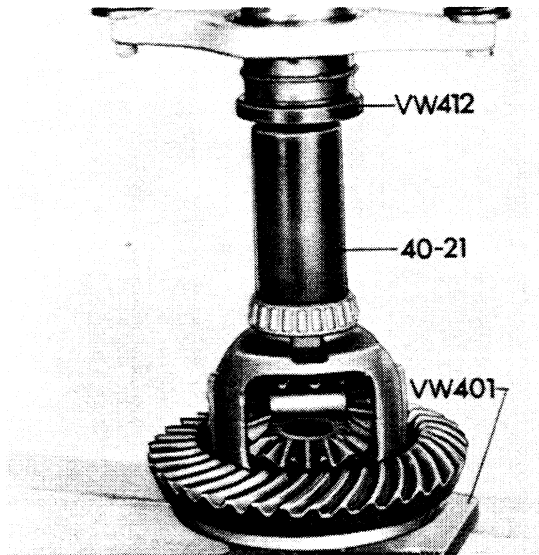

2. Install differential gears. Install large differential gears with correct shims. Install small differential gears with 180° offset (hold thrust washer in place with a little grease) and swing in. Align thrust washers with shaft bore, drive in shaft carefully and lock with a split pin.

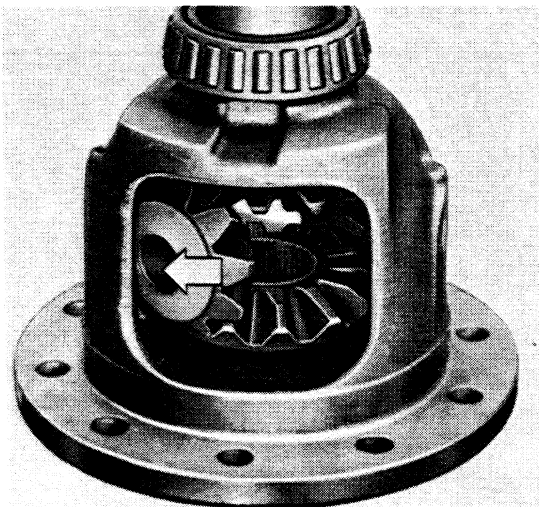

3. Heat ring gear to about 120 °C (250 °F) and install. Align bolt holes with each other with centering pins.

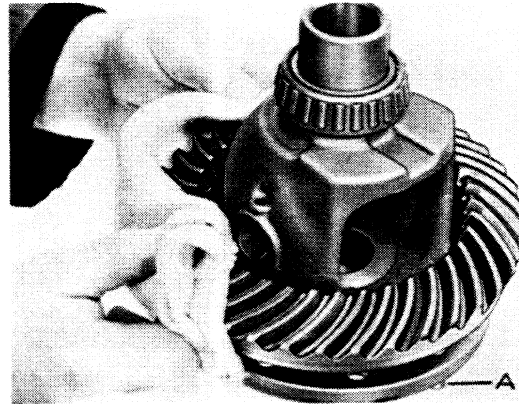

A – Centering pins

4. Tighten ring gear with new bolts and tighten bolts to specified torque crosswise.

## ADJUSTING DIFFERENTIAL GEARS

1. Install large differential gears with thinnest shims (0.5 mm).
2. Install small differential gears with thrust washers and press in shaft.

Do not mix up differential gears and thrust washers from this point on!

3. Press out small differential gears and check play of large differential gears by hand (arrows).

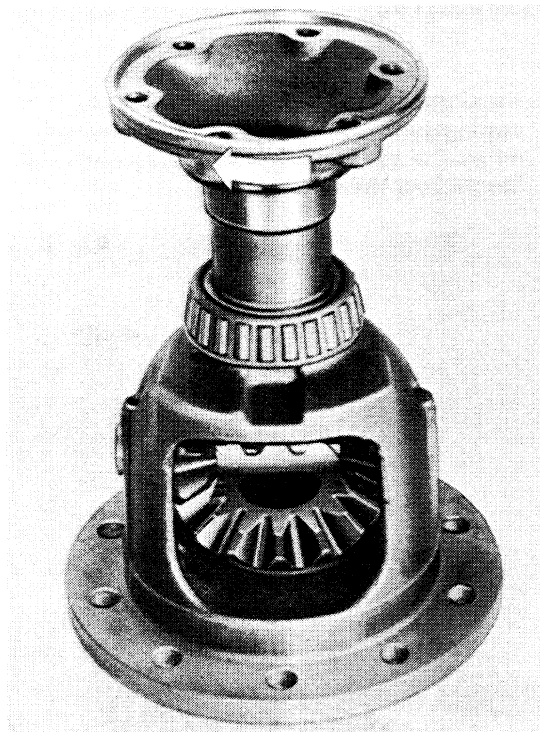
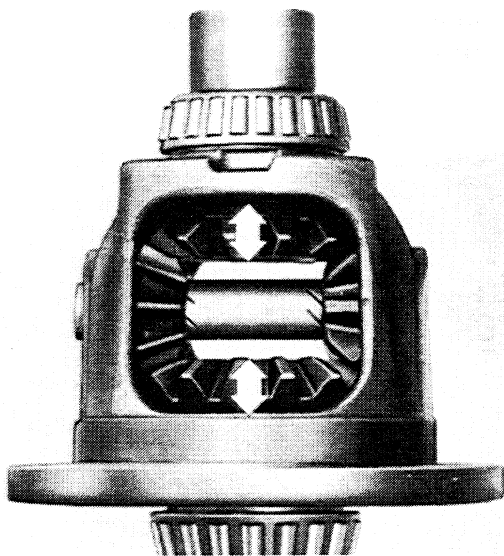

4. Adjust play to max. 0.10 mm by installing a shim of correct thickness.

Shims available:

#### Note

Adjustment is correct when no play can be felt, but the differential gears can still be turned easily and without hesitation.

| Part Number   | Thickness (mm) |
|---------------|----------------|
| 011 519 215   | 0.5            |
| 088 409 249   | 0.6            |
| 088 409 249 A | 0.7            |
| 088 409 249 B | 0.8            |

## Tools

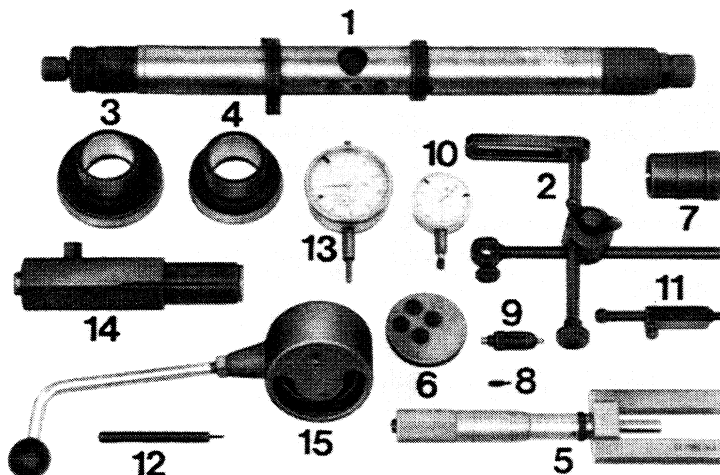

| No. | Description                    | Special tool | Remarks                        |
|-----|--------------------------------|--------------|--------------------------------|
| 1   | Universal gauge                | VW 385/1     |                                |
| 2   | Univ. dial gauge holder        | VW 387       |                                |
| 3   | Centering disk                 | VW 385/2     |                                |
| 4   | Centering disk                 | VW 385/3     |                                |
| 5   | Master gauge                   | VW 385/30    |                                |
| 6   | Gauge plate                    | VW 385/17    |                                |
| 7   | Sleeve                         | VW 521/8     |                                |
| 8   | Dial gauge extension<br>9.3 mm | VW 385/15    |                                |
| 9   | Gauge plunger                  | VW 385/14    |                                |
| 10  | Dial gauge                     |              | Standard, 3 mm measuring range |
| 11  | Adjustable lever               | VW 388       |                                |
| 12  | Dial gauge extension           |              | Standard, approx. 30 mm long   |
| 13  | Dial gauge                     |              | Standard, 5 mm measuring range |
| 14  | Adjusting device               | VW 521/4     |                                |
| 15  | Torque meter                   |              | Standard, 0 to 600 Ncm         |

## ADJUSTING PINION AND RING GEAR

## Note

Careful adjustment of the drive pinion and ring gear is important to guarantee a long service life and quiet running for the final drive. This is why drive pinions and ring gears are matched during production and checked on special testing machines for the most favorable surface appearance and low noise levels in both directions of rotation. The position of quietest running is determined by moving the drive pinion in an axial direction, keeping the ring gear within specified backlash tolerances.

The deviation "r" from the master gauge "Ro" is measured and inscribed on the outside periphery of the ring gear belonging to a pinion/ring gear set supplied as a spare part. Each set (drive pinion and ring gear) may only be replaced together.

## ADJUSTMENT AND IDENTIFICATION OF PINION/RING GEAR SETS

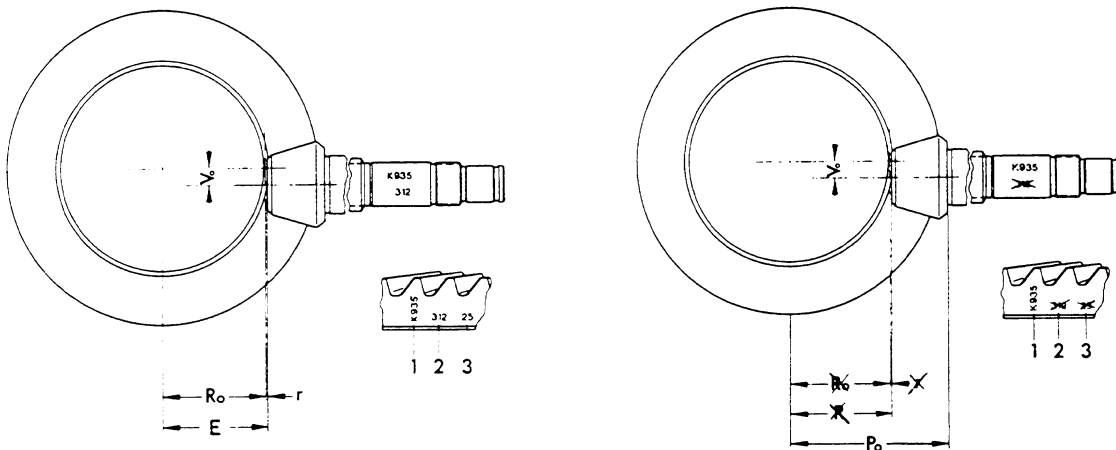

## Service Sets

- 1 – Code "K 935" means pinion/ring gear set with Klingelnberg teeth and 9 : 35 ratio. Number always has 3 digits.
- 2 – Pair code 312 of pinion/ring gear set. Number always has 3 digits.
- 3 – Deviation "r" in reference to master gauge of special testing machines used in production. Deviation "r" is always given in 1/100 mm and always has two digits.  
For example: "25" means "r" = 0.25 mm.  
Other letters or digits concern manufacturing and material batches.

Ro – Length of master gauge used in special testing machine.

## Standard Sets

## Important!

In production the location of the drive pinion is given by distance Po (center of ring gear to back of pinion head). Deviation "r" on the ring gear and the pair code are omitted. Because deviation "r" is not given, the installed position of the drive pinion must be measured before removing same, when replacing parts which have direct influence on the installed position of the drive pinion.

X – This data not required in production.

E – Actual distance between ring gear shaft and face of pinion at point of quietest running for this set.

Po – Hypoid displacement = 12 mm.

### Recommended Sequence of Adjusting Pinion and Ring Gear

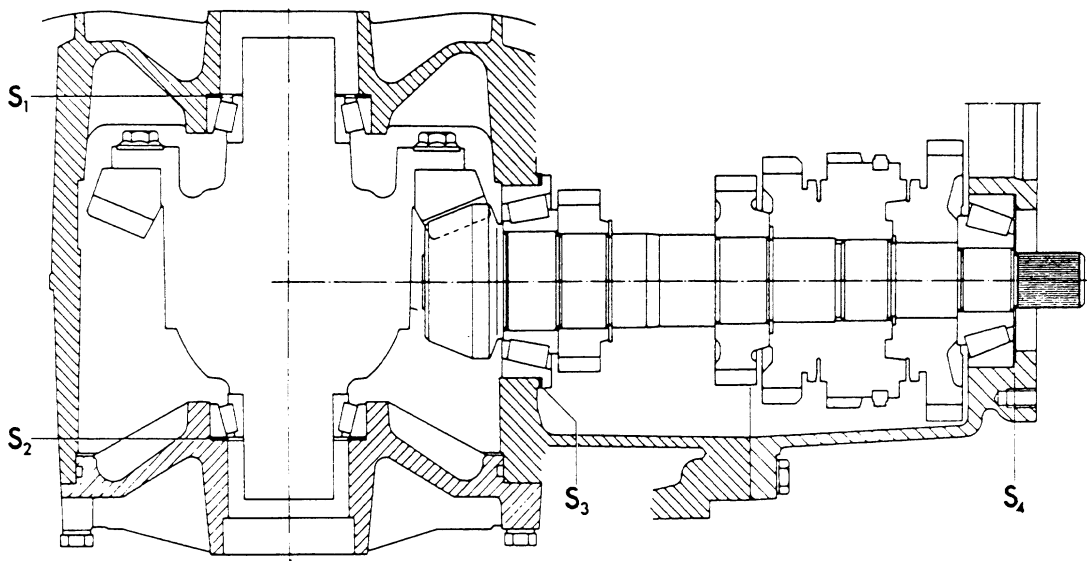

$S_1$  = Shim for ring gear

$S_2$  = Shim for ring gear

$S_3$  = Shim for pinion

$S_4$  = Shim for pinion

The goal of adjustments is to relocate the point of optimal quiet running as was determined in the special testing machine during production.

Perfect results require absolute care and cleanliness during all assembly and measuring operations.

When it becomes necessary to adjust the pinion and ring gear, it would be in the interest of economical procedures to keep to the following sequence.

- 1 – Determine the total shim thickness " $S_{tot}$ " ( $S_1$  plus  $S_2$ ) for the specified pre-load of tapered roller bearing/differential.
- 2 – Determine the total shim thickness " $S_{tot}$ " ( $S_3$  plus  $S_4$ ) for the specified pre-load of tapered roller bearing/drive pinion.
- 3 – Divide total shim thickness " $S_{tot}$ " in  $S_3$  and  $S_4$  that the distance from center of ring gear to face of drive pinion is equal to distance "E" determined during production.
- 4 – Divide total shim thickness " $S_{tot}$ " in  $S_1$  and  $S_2$  so that there is the specified amount of backlash between the ring gear and pinion.

## Adjustment Survey

The pinion and ring gear only have to be adjusted when repairs on the final drive require the replacement of parts having direct influence on the adjustment. Refer to the following table to avoid unnecessary adjustments!

| Replaced Part                              | Ring Gear<br>( $S_1 + S_2$ ) | Pinion<br>Deviation | Pinion<br>"Actual"<br>distance | Pinion<br>only shim<br>"S <sub>4</sub> " |
|--|------------------------------|---------------------|--------------------------------|--|
| Transmission case                          | X                            |                     | X                              |  |
| Gear carrier housing                       |                              |                     |                                | X  |
| Differential housing                       | X                            |                     |                                |  |
| Tapered roller bearing<br>for pinion       |                              |                     | X                              |  |
| Tapered roller bearing<br>for differential | X                            |                     |                                |  |
| Pinion/ring gear                           | X                            | X                   |                                |  |
| Final drive cover                          | X                            |                     |                                |  |

#### Determining Installed Position of Drive Pinion (Actual Distance)

This operation is only necessary when deviation "r" is not given on the ring gear and parts have to be replaced, which have direct influence on the drive pinion position. These would be both tapered roller bearings for drive pinion and transmission case.

#### Removing Differential

Complete universal gauge as shown in the list of tools, insert in transmission case and measure difference to "Ro" (max. deflection/point of reversal). Measured value will be equal to deviation "r".

Adjust drive pinion as described after replacing parts. Use the deviation "r" used for determination of shim thickness "S<sub>3</sub>".

### Adjusting Drive Pinion

Adjustment of the pinion/ring gear according to the following instructions will only be necessary when replacing the pinion/ring gear. Make adjustments with help of the previously determined installed position (actual distance), if other parts with influence on the drive pinion are being replaced.

#### Determining Total Shim Thickness $S_{tot}$ ( $S_3$ plus $S_4$ )

1. Install tapered roller bearing outer race without shims in transmission case or gear carrier.
2. Install completely assembled drive pinion. Mount gear carrier and tighten bolts to torque of 25 Nm (18 ft lb).
3. Turn drive pinion about 20 full revolutions by hand so that both tapered roller bearings are pre-loaded, while lifting and lowering drive pinion.

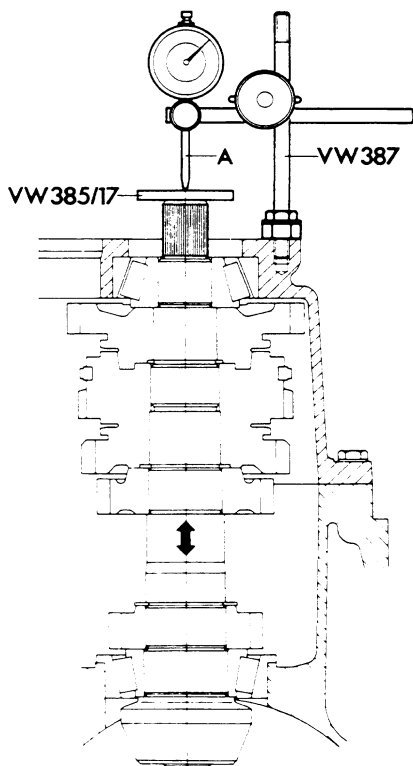

4. Mount gauges.  
Set dial gauge (3 mm range) to 0 with 1 mm pre-load. Dial gauge extension length approx. 30 mm.
5. Move drive pinion up and down. Read play on dial gauge and note the value. Do not turn drive pinion during this step to avoid wrong readings. Example: 1.30 mm.
6. Take off gear carrier again.

#### Determining Total Shim Thickness " $S_{tot}$ " ( $S_3$ plus $S_4$ )

$$\begin{aligned}
 S_{tot} &= \text{measured value} + \text{pre-load} \\
 \text{Pre-load} &= 0.30 \text{ mm (constant value)} \\
 \text{Measured value} &= \underline{1.30 \text{ mm (example)}} \\
 S_{tot} &= 1.60 \text{ mm}
 \end{aligned}$$

#### Determining Deviation "r"

1. Install shim of determined thickness (1.60 mm in the example) behind tapered roller bearing outer race in gear carrier ( $S_4$  side). Mount gear carrier again, bolt and turn drive pinion in both directions about 20 revolutions each.
2. Adjust set ring of gauge VW 385/1 to distance "a".



a = approx. 50 mm



3. Complete universal gauge as shown.

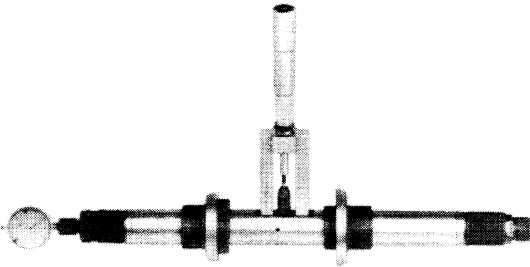

4. Use dial gauge extension VW 385/15 with length = 9.3 mm.

5. Set the master gauge to

$R_o = 59.65 \text{ mm}$  (016 J/K up to Mod. '88)

$R_o = 58.15 \text{ mm}$  (016 J as from Mod. '89)

and mount on the universal gauge. Set the dial gauge (3 mm range) to zero with 1 mm pre-load.

6. Move the adjustable set ring back against the stop.

7. Place gauge plate VW 385/17 (with magnet) on the pinion head.

8. Remove the master gauge and insert the universal gauge into the housing (installed position). Centering disk VW 385/2 for final drive cover.

9. Mount final drive cover carefully (do not knock, risk of gauge plate slipping). Remove the toroidal sealing ring, for practical reasons, and tighten the cover with 4 screws.

10. Pull the second centering disk outwards with the adjustable set ring so that the universal gauge can still just be turned by hand.

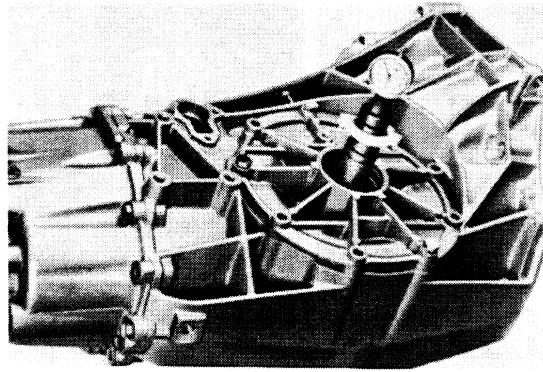

11. Turn the universal gauge until the dial gauge probe makes contact with the gauge plate on the pinion head and the dial indicates max. deflection (reversing point). The measured value is dimension "e" (black number scale). For example: 0.46 mm.

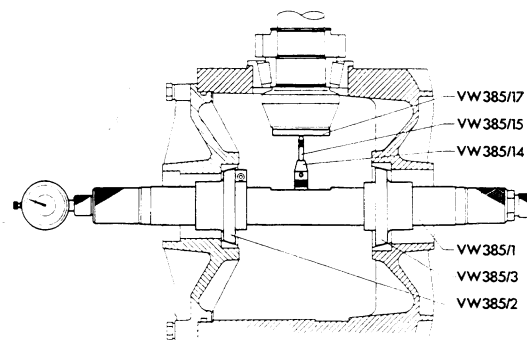

**Determining the thickness of shim "S3"**

$$S3 = e + r$$

e = Determined value  
(max. dial gauge deflection)

r = Deviation (given on the ring gear in  
1/100 mm or determined by measuring  
the actual distance)

Example:

|   |           |
|---|-----------|
| Value indicated<br>on the dial gauge "e"      | 0.46 mm   |
| Deviation value<br>given on the ring gear "r" | + 0.18 mm |
|   | <hr/>     |
| Shim thickness "S3"                           | 0.64 mm   |

S3 shims available as spare parts:

Thickness (mm)

0.20

0.25

0.30

0.35

0.40

0.65

0.90

1.15

**Note**

Any thickness for "S<sub>3</sub>" is possible due to the tolerances of the shims. Measure shim thickness at many different points with a micrometer. Also check shims for burrs or damage. Only install shims in perfect condition.

**Determining Thickness of Shim "S<sub>4</sub>"**

$$S_4 = S_{\text{tot}} - S_3$$

**Example:**

|                               |           |
|-------------------------------|-----------|
| Total shim thickness          | 1.60 mm   |
| Shim thickness S <sub>3</sub> | – 0.64 mm |
| Shim thickness S <sub>4</sub> | 0.96 mm   |

**Available shims S<sub>4</sub>**

| Thickness (mm) |
|----------------|
| 0.24           |
| 0.27           |
| 0.30           |
| 0.33           |
| 0.36           |
| 0.39           |
| 0.42           |
| 0.45           |
| 0.69           |
| 0.93           |
| 1.17           |
| 1.41           |

Measure thickness of shims at many different points with a micrometer. Also check shims for burrs or damage. Only install shims in perfect condition.

**Checking Distance "E"**

1. Install drive pinion with measured shims S<sub>3</sub> and S<sub>4</sub>. Bolt gear carrier and turn drive pinion in both directions about 20 full revolutions by hand so that the tapered roller bearings will be loaded by the rotation and can settle.
2. Apply universal gauge and check distance.
3. When shims have been selected correctly, the dial gauge (read counterclockwise – red number range) should display the value of deviation "r" inscribed on the ring gear with a tolerance of ± 0.04 mm.

**Checking Pre-load of Tapered Roller Bearing on Drive Pinion**

Screw bolt in drive pinion. Apply torque meter and read friction torque.

For new bearings it should be 200 to 400 Ncm or 30 to 60 Ncm for used bearings.

**Note**

Lubricate bearings with hypoid gear lube.

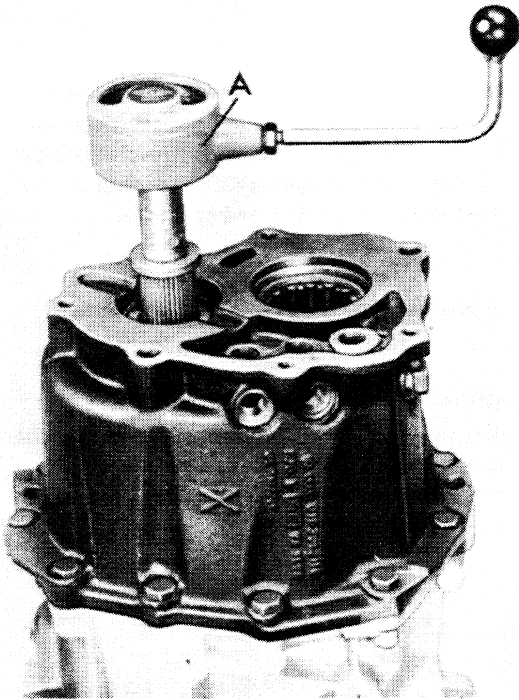

### Determining Total Shim Thickness " $S_{tot}$ " ( $S_1$ plus $S_2$ )

(For determination of pre-load for tapered roller bearings on differential.)

1. Remove drive pinion.
2. Remove seals for shaft flanges.
3. Remove outer races of tapered roller bearings for differential. Take out shims.
4. Drive in tapered roller bearing outer races without shims against stop.
5. Place differential in case. Installed position: ring gear facing cover.
6. Install cover and tighten bolts crosswise to 25 Nm (18 ft lb).
7. Clamp transmission in assembly stand with cover facing up.

A – Torque meter, standard, 0 . . . 600 Ncm

### Adjusting Ring Gear

#### Note

The ring gear has to be adjusted, if

transmission case,  
final drive cover,  
tapered roller bearings for differential  
and/or pinion/ring gear set

are replaced (also refer to "necessary adjustments").

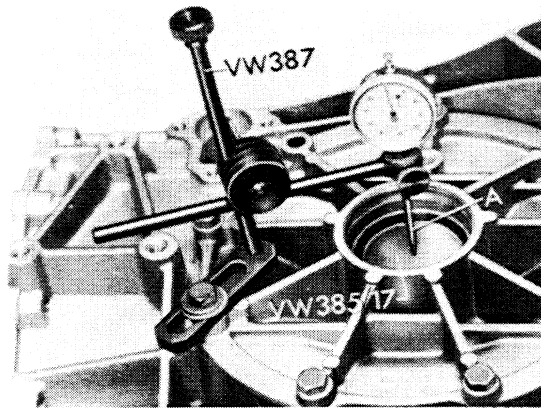

A – Dial gauge extension approx. 30 mm

8. Place gauge plate VW 385/17 on collar of differential.

9. Mount universal dial gauge holder VW 387 with dial gauge and extension on case and set dial gauge to zero with 1 mm pre-load.
10. Move differential up and down, read play on dial gauge and note value (e. g. 1.42 mm).

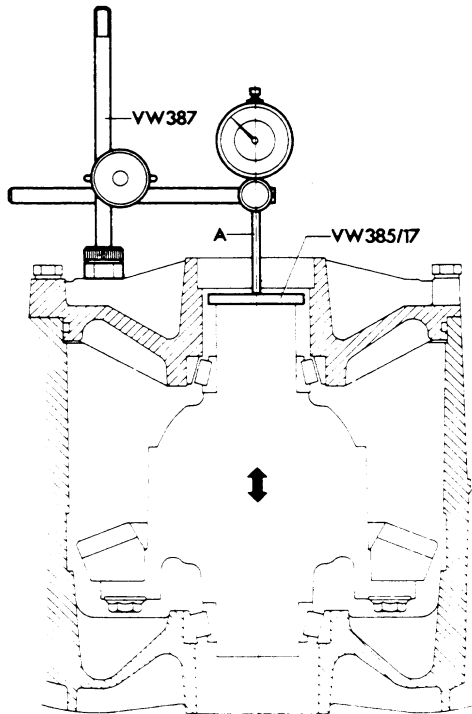

A – Dial gauge extension approx. 30 mm

#### Note

Do not turn differential while measuring play, since this would cause wrong results.

" $S_{tot}$ " = measured value + pre-load

#### Example:

|                           |           |
|---------------------------|-----------|
| Measured value (example)  | 1.42 mm   |
| Pre-load (constant value) | + 0.50 mm |
| $S_{tot}$                 | 1.92 mm   |

11. Install shims with determined total shim thickness " $S_{tot}$ " (1.92 mm in example) behind tapered roller bearing outer race in cover ( $S_2$  side). Lubricate both tapered roller bearings with hypoid oil.
12. Mount cover again.
13. Guide adjusting device VW 521/4 with sleeve VW 521/8 into neck of differential and clamp.

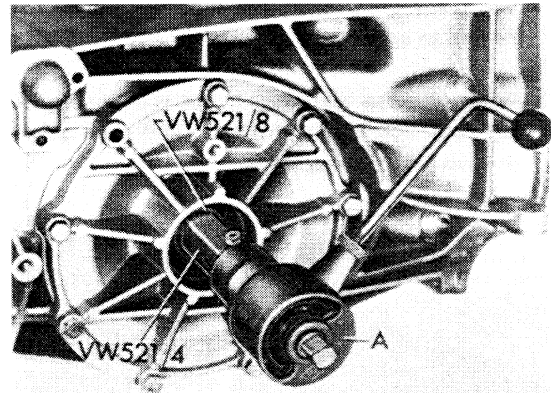

A – Torque meter, standard, 0 . . . 600 Ncm

14. Place 0 to 600 Ncm torque meter on adjusting device and turn slowly and uniformly. The friction torque of new tapered roller bearings must be at least 250 Ncm.

Friction torque of used tapered roller bearings need not be measured.

#### Note

When adjusting the pinion/ring gear set, now check the drive pinion adjustment.

## Adjusting Backlash

Requirement: drive pinion adjusted and installed with  $S_3$  and  $S_4$ .

Turn differential several times to pre-load and settle tapered roller bearings.

1. Place adjustable lever VW 388 on adjusting device VW 521/4. Lever length via large hexagon surface 79 mm to upper edge of ball.
2. Apply universal dial gauge holder with dial gauge and extension so that there is a right angle between the dial gauge axis and lever.

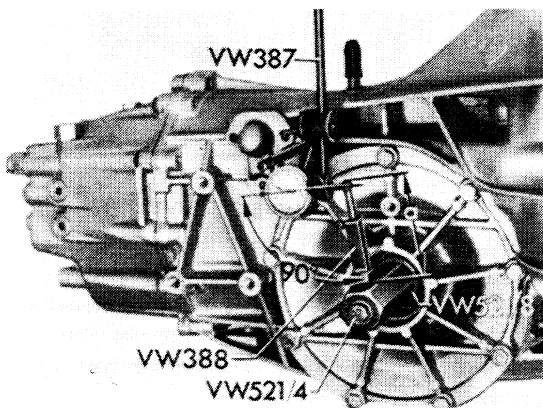

a – 79 mm

3. Turn differential counterclockwise with adjusting device VW 521/4 carefully until ring gear rests on the drive pinion.
4. Now set dial gauge to zero with 2 mm pre-load.
5. Turn differential clockwise until ring gear makes contact with the opposite flank of the next drive pinion tooth. Read backlash and note value.
6. Repeat measurement three times, turning the ring gear  $90^\circ$  further each time.
7. Add the four measured values and calculate the mean backlash value.

## Determining Mean Backlash

Example:

|                 |                |
|-----------------|----------------|
| 1st measurement | 0.84 mm        |
| 2nd measurement | 0.85 mm        |
| 3rd measurement | 0.84 mm        |
| 4th measurement | <u>0.83 mm</u> |
| Sum             | 3.36 mm        |

Mean backlash = 3.36 mm divided by 4 = 0.84 mm

Note

If the measured values deviate from each other by more than 0.06 mm, installation of the ring gear or pinion/ring gear set is not correct. Check installation, replacing pinion/ring gear if necessary.

Determining Shim Thickness  $S_2$   
(Opposite Ring Gear)

$$S_2 = S_{\text{tot}}$$

+ Lift (axial displacement of ring gear from mesh free of play to attain backlash)

– Measured mean backlash

$$S_{\text{tot}} = \text{total shim thickness } S_1 + S_2$$

Lift = 0.15 mm (constant value)

Example:

|                  |                  |
|------------------|------------------|
| $S_{\text{tot}}$ | 1.92 mm          |
| Lift             | + 0.15 mm        |
| Mean backlash    | <u>– 0.84 mm</u> |
| $S_2$            | 1.23 mm          |

Shims Available:

| Part Number   | Thickness (mm) |
|---------------|----------------|
| 113 517 201   | 0.15           |
| 113 517 202 A | 0.20           |
| 113 517 203 A | 0.30           |
| 113 517 204 A | 0.40           |
| 113 517 205 A | 0.50           |
| 113 517 206 A | 0.60           |
| 113 517 207 A | 0.70           |
| 113 517 208 A | 0.80           |
| 113 517 209 A | 0.90           |
| 113 517 210 A | 1.00           |
| 113 517 211 A | 1.20           |

It is possible to have exact shim thicknesses due to the different tolerances.

Determining Shim Thickness  $S_1$   
(Ring Gear Side)

$$S_1 = S_{\text{tot}} - S_2$$

Example:

|                  |                  |
|------------------|------------------|
| $S_{\text{tot}}$ | 1.92 mm          |
| $S_2$            | <u>- 1.23 mm</u> |
| $S_1$            | 0.69 mm          |

Shims Available:

| Part Number | Thickness (mm) |
|-------------|----------------|
| 018 409 381 | 0.15           |
| 018 409 383 | 0.20           |
| 018 409 385 | 0.25           |
| 018 409 387 | 0.50           |
| 018 409 389 | 0.80           |
| 018 409 391 | 1.00           |
| 018 409 393 | 1.50           |

It is possible to have exact shim thicknesses due to the different tolerances.

Measure thickness of shims at many different points with a micrometer. Also check shims for burrs and damage.

Only install shims in perfect condition.

Install determined shims  $S_1$  and  $S_2$ .

Checking:

Measure backlash on periphery four times.

It should be:

0.10 to 0.20 mm.

Note

Measurements must not deviate from each other by more than 0.05 mm.

### CHECKING FINAL DRIVE OIL LEVEL (AUTOMATIC TRANSMISSION)

Amount: approx. 1 liter (1.06 US qt) of hypoid gear lube SAE 90 according to API Classification GL 5 (or MIL-L 2105 B).

1. Clean outside of filler plug and unscrew.

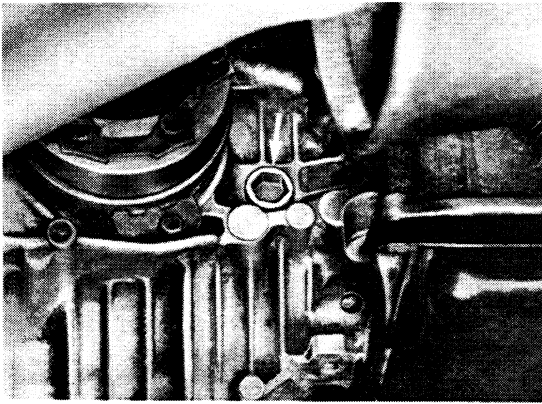

2. Oil level of car parked on level surface should reach lower edge of filler opening.
3. Clean filler plug, install and tighten to 20 Nm (14 ft lb).



## CENTRAL TUBE TORQUE SPECIFICATIONS

| Location                                   | Description | Threads   | Material | Torque<br>Nm (ft lb) |
|--|-------------|-----------|----------|----------------------|
| Converter bearing to rear bell housing     | Bolt        | M 8 x 25  | 8.8      | 21<br>(15)           |
| Drive shaft to flanged shaft               | Bolt        | M 10 x 46 | 12.9     | 80<br>(58)           |
| Central tube flange to clutch bell housing | Bolt        | M 10 x 35 | 8.8      | 42<br>(30)           |
| Central tube housing to transmission case  | Bolt        | M 12 x 80 | 10.9     | 85<br>(61)           |
| Central tube housing to transmission case  | Bolt        | M 10 x 50 | 8.8      | 42<br>(30)           |
| Converter to drive plate                   | Bolt        | M 8 x 11  | 12.9     | 40<br>(29)           |
| Drive shaft and damper                     | Bolt        | M 10 x 46 | 12.9     | 80<br>(58)           |
| Damper to flywheel                         | Bolt        | M 8 x 40  | 8.8      | 21<br>(15)           |
| Cover to clutch bell housing               | Bolt        | M 10 x 25 | 8.8      | 42<br>(30)           |
| Support to transmission                    | Bolt        | M 10 x 30 | 8.8      | 42<br>(30)           |
| Hook to central tube                       | Nut         | M 8       | 8        | 20<br>(14)           |

FINAL DRIVE TORQUE SPECIFICATIONS  
(AUTOMATIC TRANSMISSION)

| Location                               | Description | Threads    | Material | Torque<br>Nm (ft lb) |
|--|-------------|------------|----------|----------------------|
| Flanged shaft to differential          | Bolt        | M 8 x 1.25 | 8.8      | 25<br>(18)           |
| Lockplate to adjusting ring            | Bolt        | M 6 x 1    | 8.8      | 8<br>(6)             |
| Pinion shaft cover to final drive case | Bolt        | M 10 x 1.5 | 10.9     | 42<br>(30)           |
| Final drive cover to case              | Bolt        | M 8 x 1.25 | 10.9     | 25<br>(18)           |
| Ring gear to differential              | Bolt        | M 10 x 1   | 12.9     | 78 – 93<br>(56 – 67) |
| Automatic transmission to final drive  | Nut         | M 8 x 1.25 | 12.9     | 29<br>(21)           |
| Drive shaft to transmission flange     | Bolt        | M 8        | 12.9     | 42<br>(30)           |

### CHECKING OIL LEVEL IN FINAL DRIVE (AUTOMATIC TRANSMISSION)

Capacity: approx. 1 liter (US qt) of hypoid gear lube  
SAE 90 acc. API Classification GL 5 (or MIL-L 2105 B).

1. Clean outside of filler plug and unscrew.

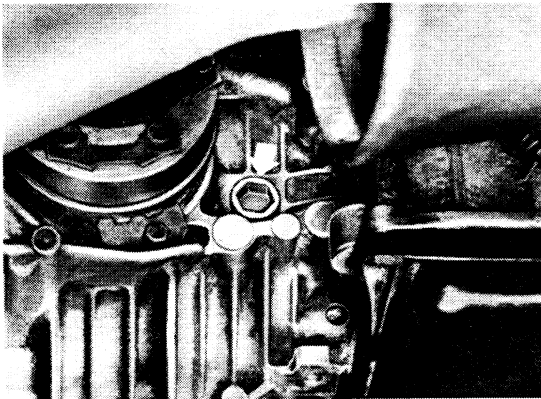

2. Oil level of car parked on level ground should reach lower edge of filler opening.
3. Clean and screw in filler bolt (tightening torque: 20 Nm – 14 ft lb).

TOOLS

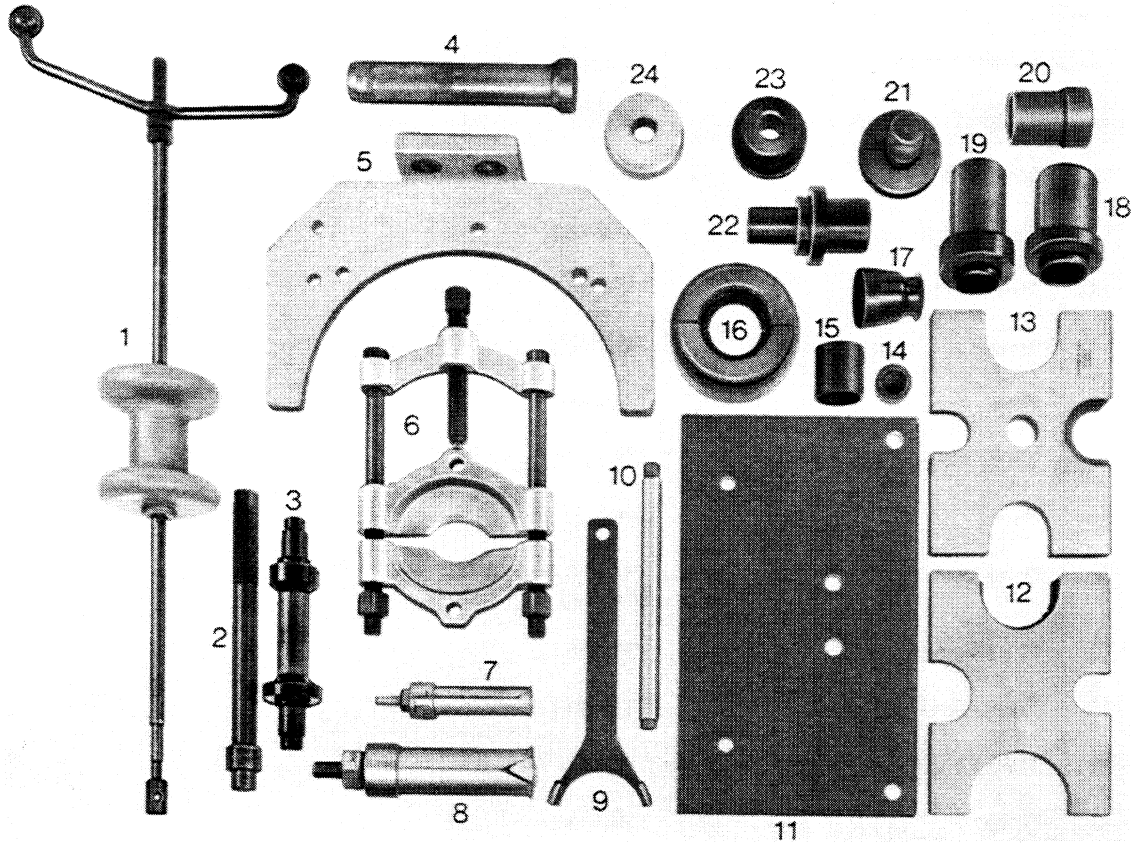

| No. | Description          | Special Tool | Remarks |
|-----|----------------------|--------------|---------|
| 1   | Slide hammer         | VW 771       |         |
| 2   | Drift                | VW 295       |         |
| 3   | Driving mandrel      | 2056         |         |
| 4   | Sleeve               | 30 - 21      |         |
| 5   | Transmission support | VW 353       |         |
| 6   | Separator            | US 1103      |         |
| 7   | Internal puller      | US 1108      |         |
| 8   | Internal puller      | US 1137      |         |

| No. | Description       | Special Tool         | Remarks      |
|-----|-------------------|----------------------|--------------|
| 9   | Spanner wrench    | VW 544               |              |
| 10  | Mandrel guide pin | VW 439               |              |
| 11  | Mounting plate    | –                    | Made locally |
| 12  | Thrust plate      | VW 402               |              |
| 13  | Thrust plate      | VW 401               |              |
| 14  | Spacer            | VW 545/2             |              |
| 15  | Tube              | VW 516               |              |
| 16  | Thrust rings      | VW 470               |              |
| 17  | Sleeve            | 2055                 |              |
| 18  | Drive sleeve      | VW 192 or<br>US 4450 |              |
| 19  | Drive sleeve      | VW 551               |              |
| 20  | Thrust tube       | VW 454               |              |
| 21  | Thrust pad        | VW 412               |              |
| 22  | Driver            | VW 195               |              |
| 23  | Thrust pad        | 30 - 205             |              |
| 24  | Thrust pad        | VW 510               |              |

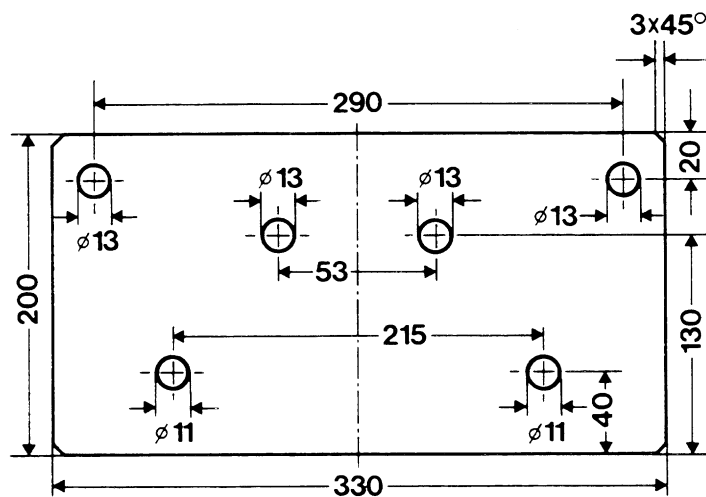

Locally made plate – 10 mm thick (item 11)

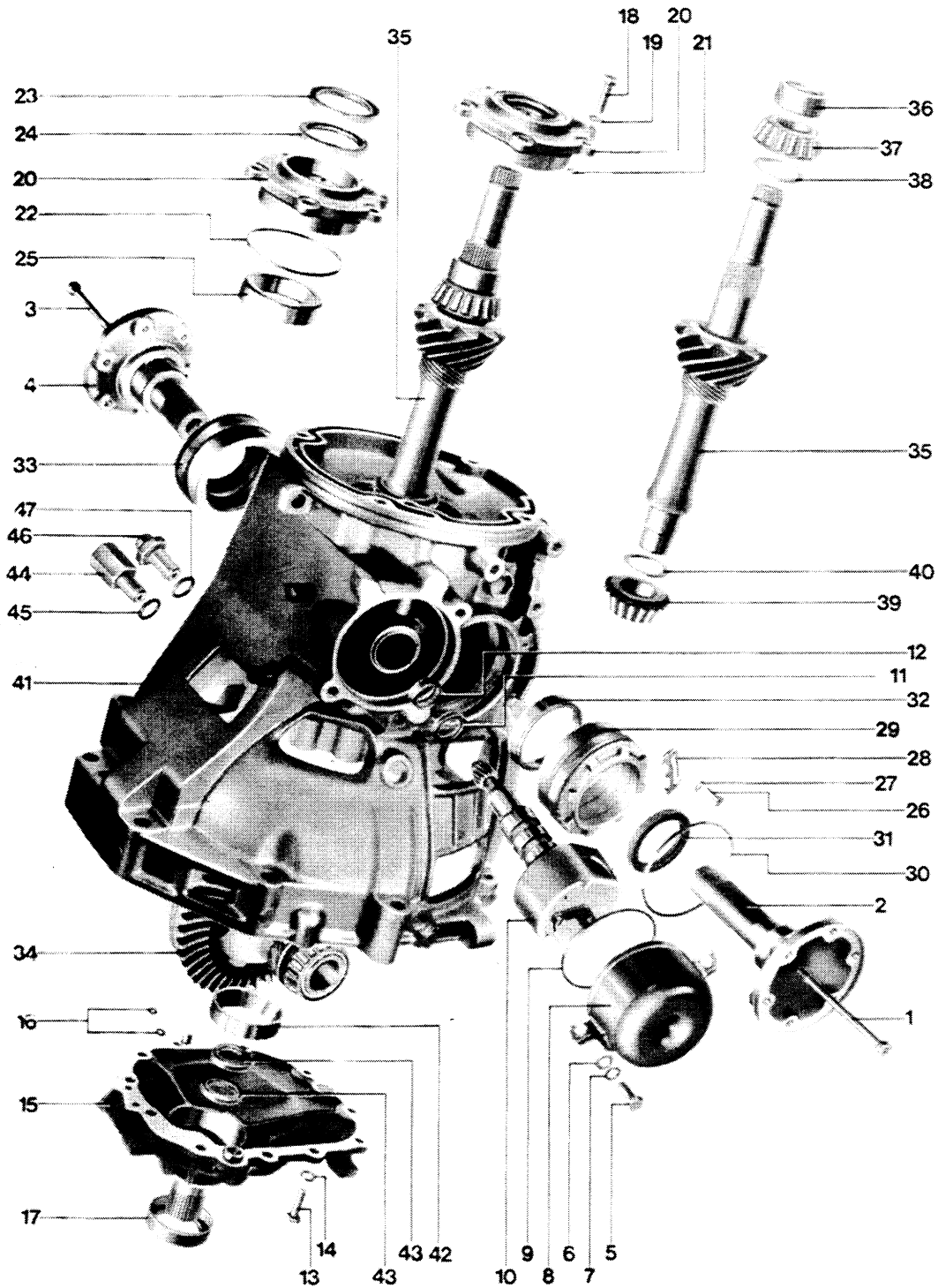

| No. | Description    | Qty. | Note When:               |  | Special Instructions |
|-----|----------------|------|--------------------------|--|----------------------|
|     |                |      | Removing                 | Installing                                     |                      |
| 1   | Bolt           | 1    | Hold flange with mandrel | Torque:<br>25 Nm (18 ft lb)                    |                      |
| 2   | Flanged shaft  | 1    |                          |  |                      |
| 3   | Bolt           | 1    | Hold flange with mandrel | Torque:<br>25 Nm (18 ft lb)                    |                      |
| 4   | Flanged shaft  | 1    |                          |  |                      |
| 5   | Bolt           | 1    |                          | Torque:<br>9 Nm (7 ft lb)                      |                      |
| 6   | Washer         | 1    |                          |  |                      |
| 7   | Washer         | 1    |                          |  |                      |
| 8   | Governor cover | 1    |                          |  |                      |
| 9   | Seal           | 1    |                          | Replace  |                      |
| 10  | Governor       | 1    |                          |  |                      |
| 11  | Seal           | 1    | Pull out with US 1088    | Drive in against stop with VW 295 and VW 545/2 |                      |
| 12  | Needle bearing | 1    | Pull out with US 1088    | Drive in against stop with VW 295              |                      |
| 13  | Bolt           | 11   |                          | Torque:<br>25 Nm (18 ft lb)                    |                      |
| 14  | Lock washer    | 11   |                          | Replace if necessary                           |                      |
| 15  | Cover          | 1    |                          | Coat sealing surface with D 3 sealer           |                      |
| 16  | Seal           | 2    |                          | Replace, do not forget when assembling         |                      |
| 17  | Seal           | 1    | Drive off with chisel    | Drive on with VW 192 or US 4450                |                      |

| No. | Description                          | Qty. | Note When:  |  | Special Instructions |
|-----|--------------------------------------|------|---|--|----------------------|
|     |                                      |      | Removing  | Installing   |                      |
| 18  | Bolt                                 | 5    |   | Torque:<br>42 Nm (30 ft lb)  |                      |
| 19  | Lock washer                          | 5    |   | Replace if necessary   |                      |
| 20  | Cover                                | 1    |   |  |                      |
| 21  | Seal                                 | 1    |   | Replace, do not forget<br>when assembling  |                      |
| 22  | Seal                                 | 1    |   |  |                      |
| 23  | Seal                                 | 1    | Drive out with<br>screwdriver   | Drive in flush with<br>VW 295 and 30 - 205   |                      |
| 24  | Seal                                 | 1    | Drive out with<br>screwdriver   | Drive in against stop<br>with VW 551   |                      |
| 25  | Tapered roller<br>bearing outer race | 1    | Drive out with<br>suitable drift  | Press in with 30 - 205   |                      |
| 26  | Bolt                                 | 2    |   | Torque:<br>8 Nm (6 ft lb)  |                      |
| 27  | Washer                               | 2    |   |  |                      |
| 28  | Lockplate                            | 2    |   |  |                      |
| 29  | Adjusting ring                       | 1    | When used rings are<br>reinstalled, mark<br>position before<br>removing | Adjust when new or<br>turn to marked<br>position   |                      |
| 30  | Seal                                 | 2    |   |  |                      |
| 31  | Seal                                 | 2    | Can also be replaced<br>without removing<br>transmission                | Before installing fill<br>space between sealing<br>lips with all-purpose<br>grease. Drive in against<br>stop with VW 195 |                      |
| 32  | Tapered roller<br>bearing outer race | 2    |   | Press in with VW 295<br>and 30 - 205   |                      |
| 33  | Adjusting ring                       | 1    | When used rings are<br>reinstalled, mark<br>position before<br>removing | Adjust when new or<br>turn to marked<br>position   |                      |



| No. | Description            | Qty. | Note When:             |  | Special Instructions |
|-----|------------------------|------|------------------------|--|----------------------|
|     |                        |      | Removing               | Installing   |                      |
| 34  | Differential           | 1    |                        | Adjust ring gear when installing new case                              |                      |
| 35  | Pinion                 | 1    |                        | Note pair number, adjust if necessary                                  |                      |
| 36  | Sleeve                 | 1    | Press off              | Heat to approx. 100 °C/212 °F and press on                             |                      |
| 37  | Tapered roller bearing | 1    | Press off              | Heat to approx. 100 °C/212 °F and press on. Adjust if replacing pinion |                      |
| 38  | Shim                   | X    |                        | Determine thickness  |                      |
| 39  | Tapered roller bearing | 1    | Press off              | Heat to approx. 100 °C/212 °F and press on. Adjust if replacing pinion |                      |
| 40  | Shim S 4               | X    |                        | Determine thickness  |                      |
| 41  | Case                   | 1    |                        |  |                      |
| 42  | Outer race, tapered    | 1    | Press off with US 1108 | Press in with VW 510   |                      |
| 43  | Seal                   | 2    | Press off with US 1037 | Position correctly, drive on with 2056                                 |                      |
| 44  | Adapter                | 1    |                        | Torque:<br>80 Nm (58 ft lb)  |                      |
| 45  | Seal                   | 1    |                        | Replace  |                      |
| 46  | Adapter                | 1    |                        | Torque:<br>80 Nm (58 ft lb)  |                      |
| 47  | Seal                   | 1    |                        | Replace  |                      |

## DISASSEMBLING AND ASSEMBLING FINAL DRIVE

## Disassembling

## Note :

If pinion/ring gear and bearings can be reused, determine backlash and turning torque of pinion before disassembling final drive, note these figures and install them again as accurately as possible.

1. Mount final drive on assembly stand with VW 353 and locally made plate.

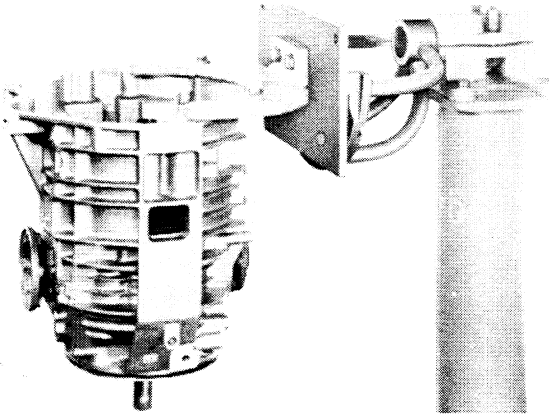

2. Unscrew adjusting ring with VW 544.

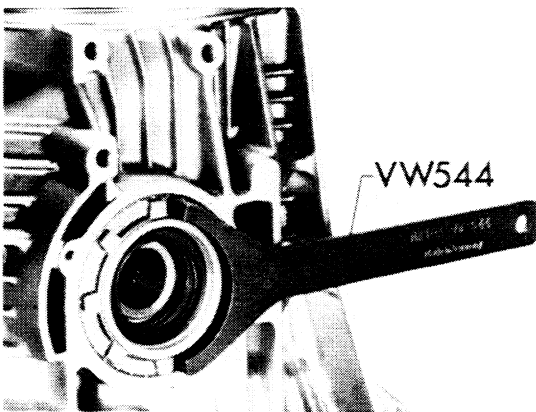

3. Remove differential and pinion by removing both covers, unscrewing adjusting rings and pulling pinion out a little way through large opening. Tilt differential aside carefully and remove pinion.

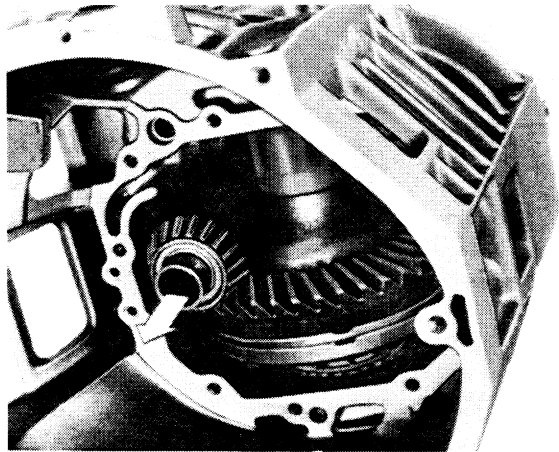

4. Pull out seal and needle bearing for governor together.

A – US 1088

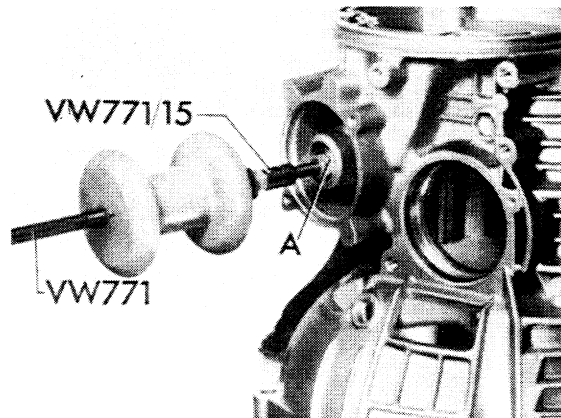

## Assembling

1. Drive in needle bearing for governor against stop

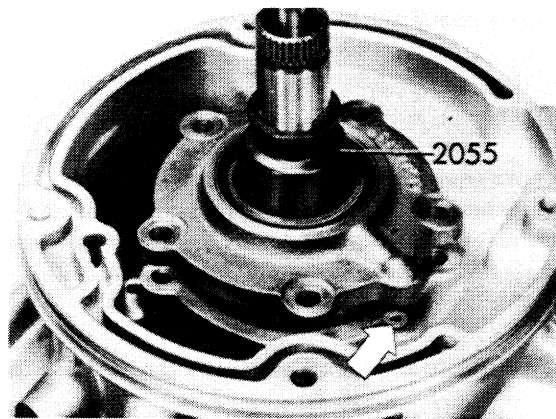
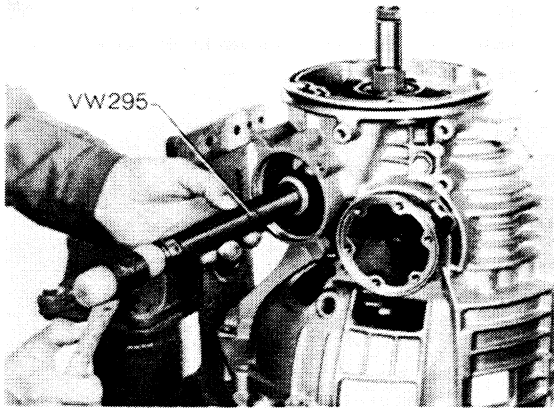

2. Drive in governor seal against stop.

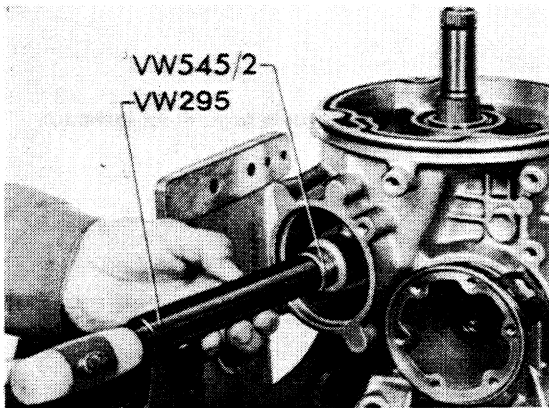

4. Drive flanged shaft seal into adjusting ring against stop.

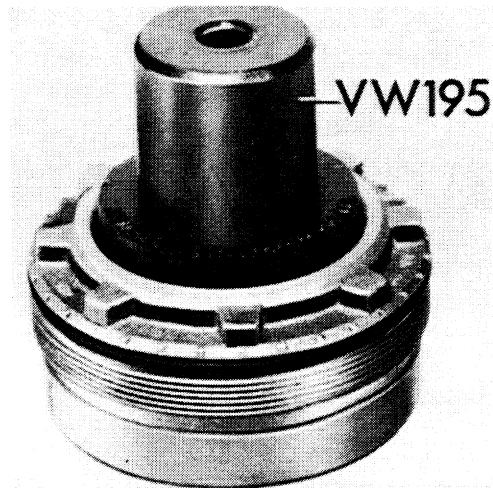

3. Install drive pinion cover. Insert oil bore seal (arrow).  
Always use sleeve 2055; otherwise seals would be damaged.

5. Press outer race for tapered roller bearing into adjusting ring.

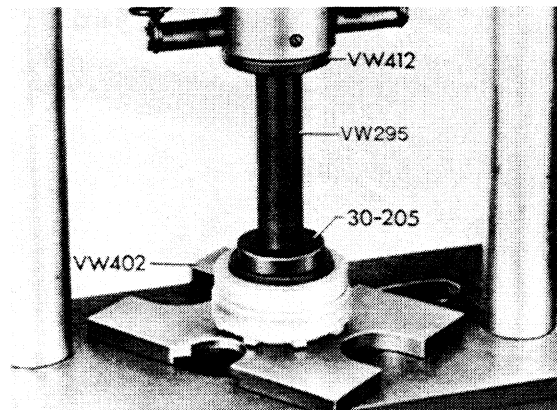

DISASSEMBLING AND ASSEMBLING FINAL DRIVE CASE COVER

Disassembling

1. Remove torque converter seal.

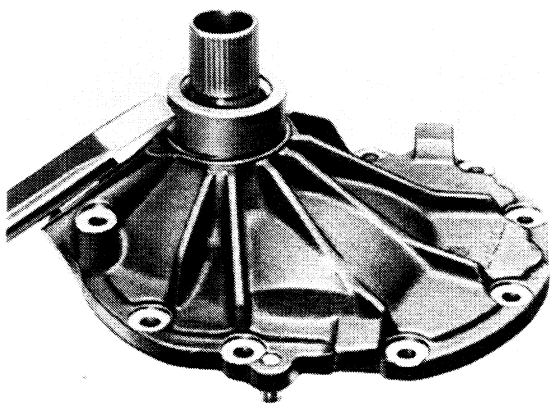

2. Press seals out of cover.

A – US 1108

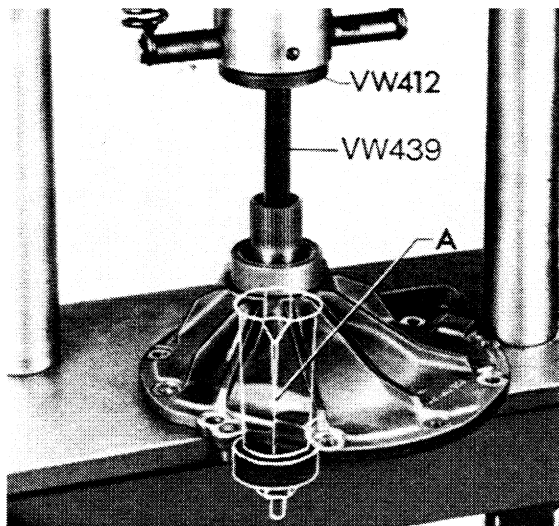

3. Press out outer race for tapered roller bearing.  
A – US 1037

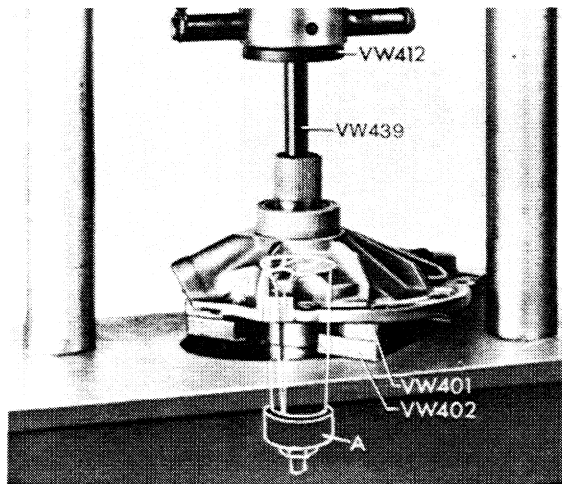

Assembling

1. Press in outer race for tapered roller bearing.

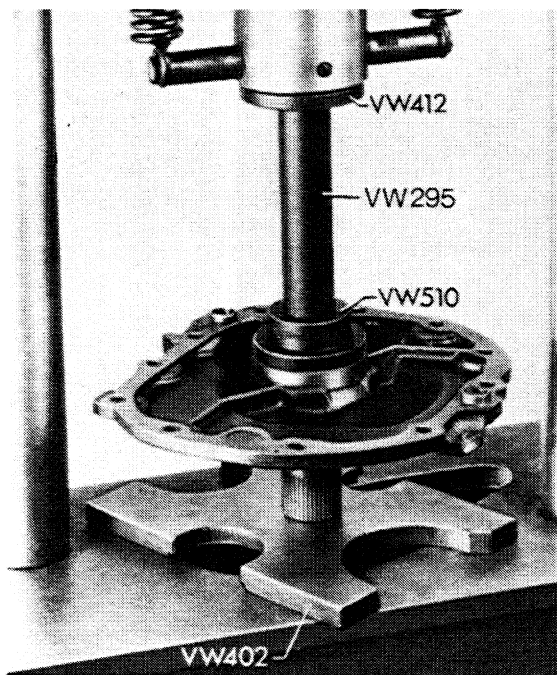

2. Drive first seal into cover against stop. Open end of seal faces converter. Small shoulder on mandrel faces down.

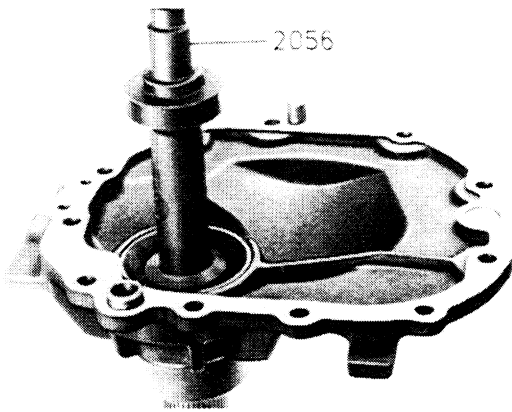

4. Drive in torque converter seal.

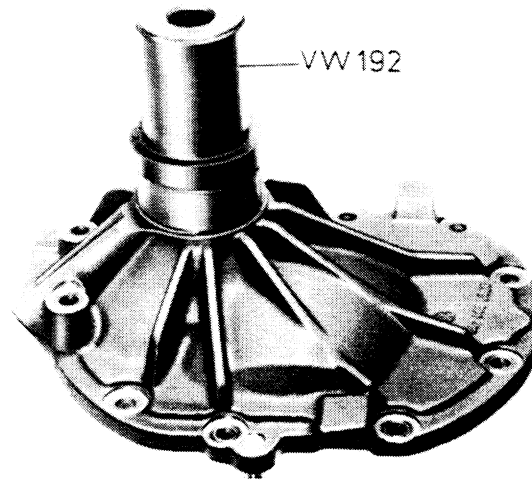

3. Drive second seal into cover until flush. Open end of seal faces transmission. Large shoulder on mandrel serves as stop.

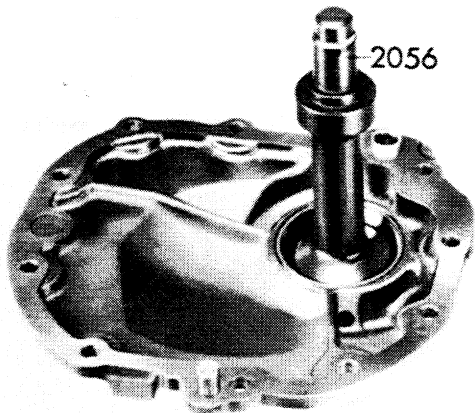

3. Drive in second seal until flush.  
Open end of seal faces automatic transmission assembly.

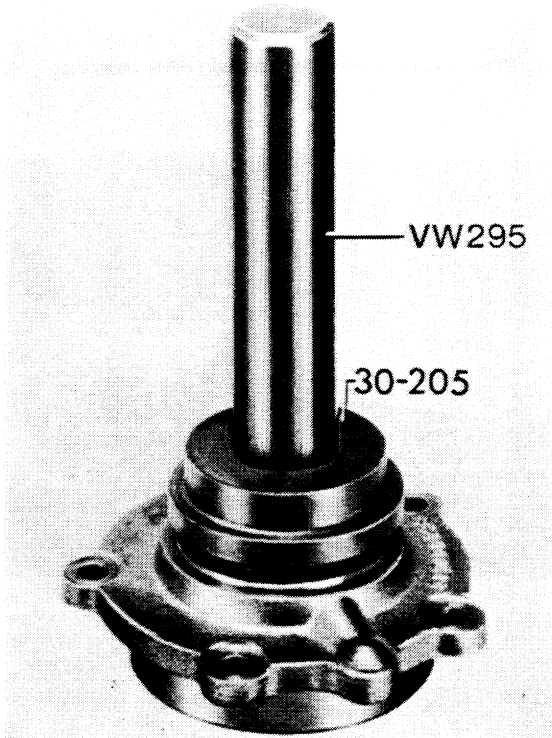

4. Position seals correctly.

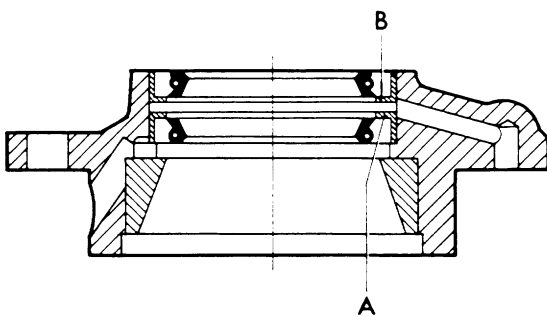

- A – Seal – final drive  
B – Seal – automatic transmission assembly

DISASSEMBLING AND ASSEMBLING PINION

Disassembling

1. Press off tapered roller bearing (small bearing).

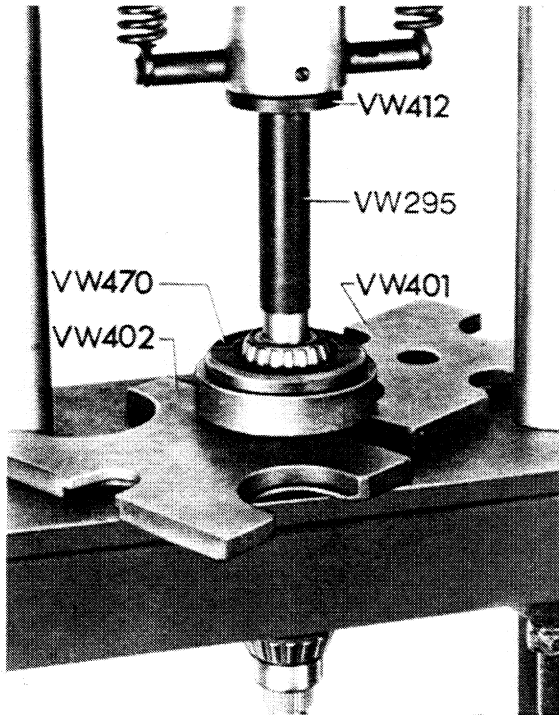

3. Press off tapered roller bearing (large bearing).  
A – US 1103

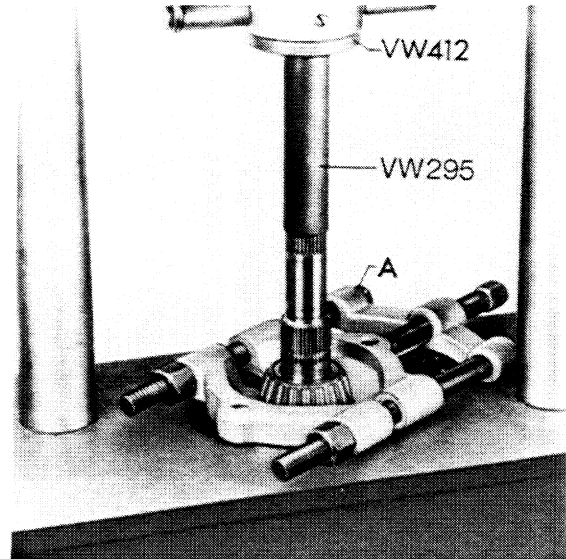

2. Press off sleeve for seals.

A – US 1103

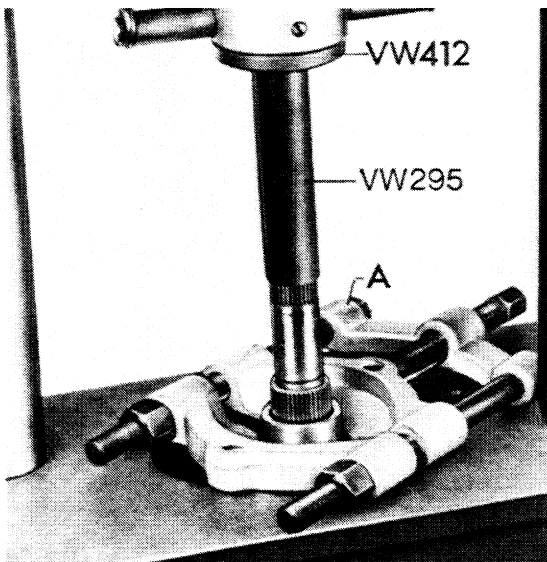

Assembling

1. Heat large tapered roller bearing to approx. 100 °C/212 °F and install. Then press on tight.

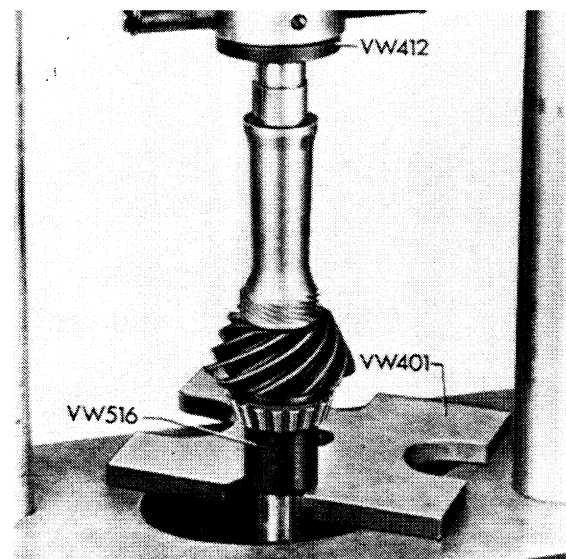

- Heat sleeve for seals to approx.  $100^{\circ}\text{C}/212^{\circ}\text{F}$  and install. Then press on tight.

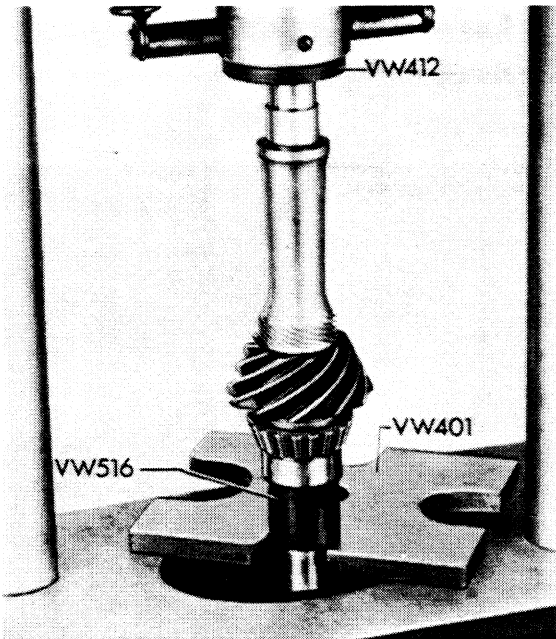

- Heat small tapered roller bearing to approx.  $100^{\circ}\text{C}/212^{\circ}\text{F}$  and install. Then press on tight.

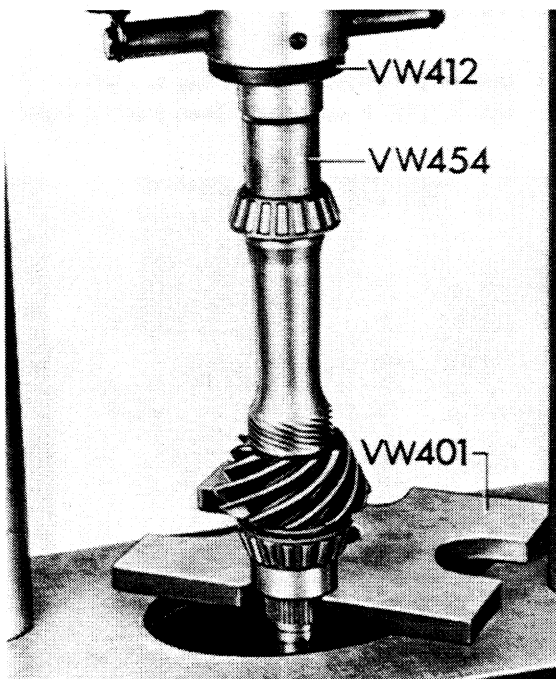



## Modifications:

Removing and installing flat governor

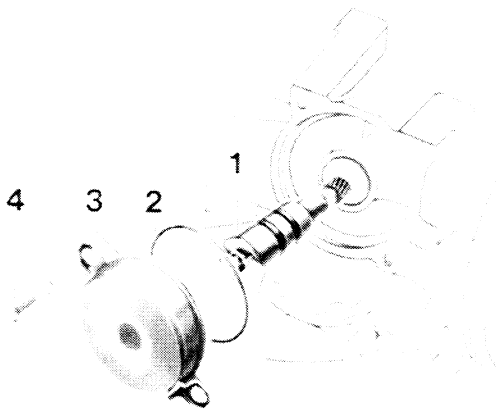

- 1 - Flat governor
- 2 - Sealing ring (always renew)
- 3 - Governor cover
- 4 - Screw

Removing and installing speedometer drive

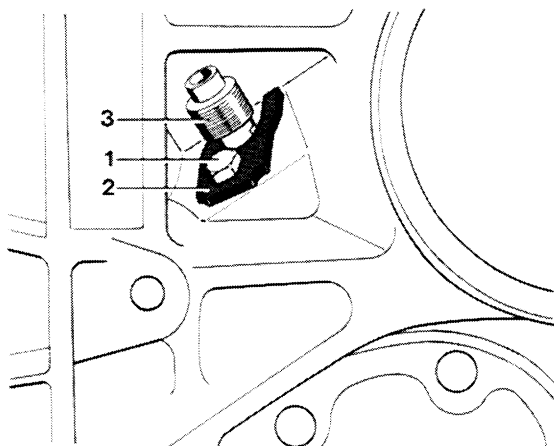

- 1 - Screw
- 2 - Retaining plate
- 3 - Drive

Disassemble speedometer drive.

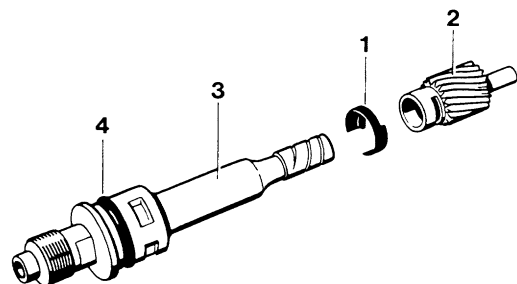

- 1 - Lock
- 2 - Pinion
- 3 - Bearing
- 4 - Sealing ring (always renew)

Lift lock (1) of pinion (2) using two screwdrivers. Remove pinion from bearing (3).

TOOLS

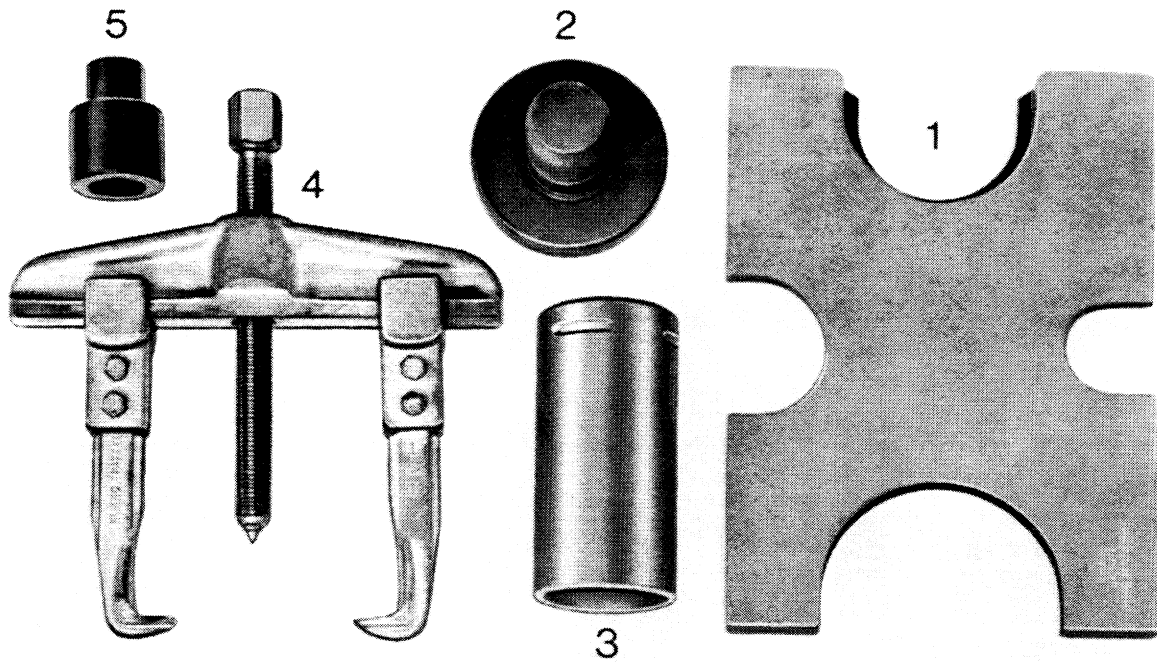

| No. | Description  | Special Tool | Remarks |
|-----|--------------|--------------|---------|
| 1   | Thrust plate | VW 402       |         |
| 2   | Thrust pad   | VW 412       |         |
| 3   | Drive sleeve | 40 - 21      |         |
| 4   | Puller       | US 1078      |         |
| 5   | Adapter      | VW 295 a     |         |

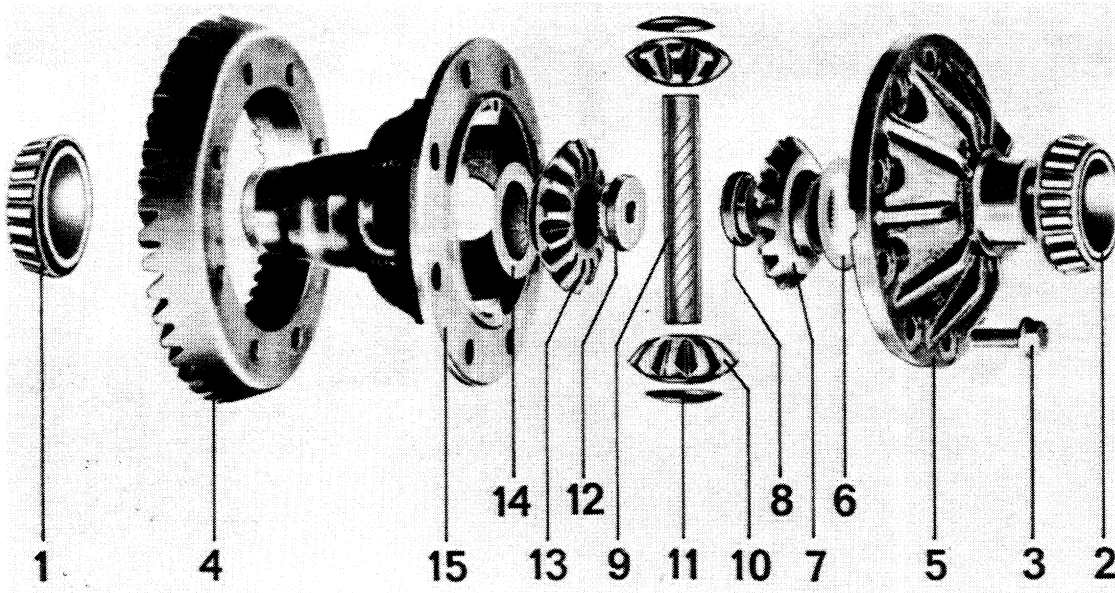

| No. | Description              | Qty. | Note When:                         |  | Special Instructions |
|-----|--------------------------|------|------------------------------------|--|----------------------|
|     |                          |      | Removing                           | Installing   |                      |
| 1   | Tapered roller bearing   | 1    | Pull off with VW 295 a and US 1078 | Heat to approx. 100 °C/212 °F. Then press on tight. Adjust ring gear if replacing                                  |                      |
| 2   | Tapered roller bearing   | 1    | Pull off with VW 295 a and US 1078 | Heat to approx. 100 °C/212 °F. Then press on tight. Adjust ring gear if replacing                                  |                      |
| 3   | Bolt                     | 10   |                                    | Torque 78 . . . 93 Nm (56 . . . 67 ft lb)  |                      |
| 4   | Ring gear                | 1    |                                    | Matched with pinion. Only replace in pairs. Heat to approx. 100 °C/212 °F. Use centering pins. Adjust if necessary |                      |
| 5   | Cover                    | 1    |                                    |  |                      |
| 6   | Thrust washer            | 1    |                                    |  |                      |
| 7   | Large differential gear  | 1    |                                    |  |                      |
| 8   | Connector, flanged shaft | 1    |                                    |  |                      |
| 9   | Shaft                    | 1    | Drive out with suitable drift      | Drive in with suitable drift. Do not damage thrust washer  |                      |
| 10  | Small differential gear  | 2    |                                    |  |                      |
| 11  | Thrust washer            | 2    |                                    | Check for cracks and breaks  |                      |
| 12  | Connector, flanged shaft | 1    |                                    |  |                      |
| 13  | Large differential gear  | 1    |                                    |  |                      |
| 14  | Thrust washer            | 1    |                                    |  |                      |
| 15  | Housing                  | 1    |                                    | Adjust ring gear after replacement   |                      |

## DISASSEMBLING AND ASSEMBLING DIFFERENTIAL

## Disassembling

1. Pull off tapered roller bearing.  
A – US 1078

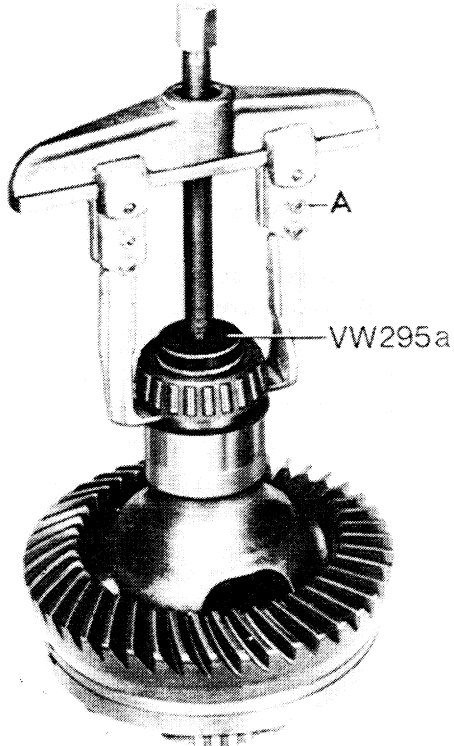

2. Clamp differential in a vise, pull off second tapered roller bearing and unscrew ring gear bolts.

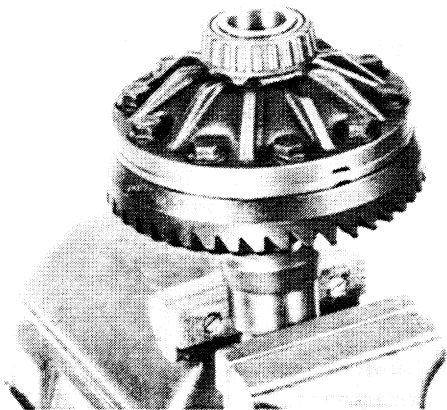

## Assembling

1. Heat ring gear to approx. 100 °C/212 °F and install. Use centering pins (made locally) to facilitate installation.

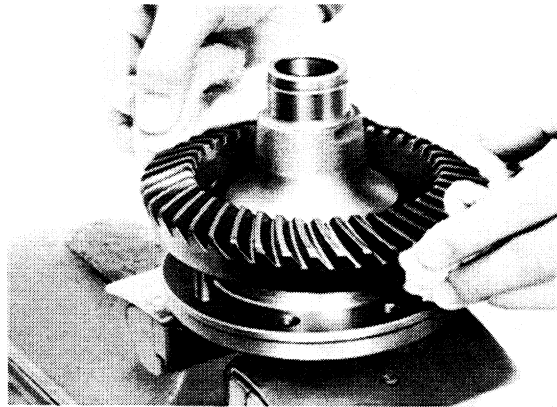

## Note :

Clean mating surfaces are important to locate ring gear, differential case and cover correctly. Smooth down burrs or high spots with an oil stone.

2. Heat tapered roller bearing to approx. 100 °C/ 212 °F and install. Then press on tight.

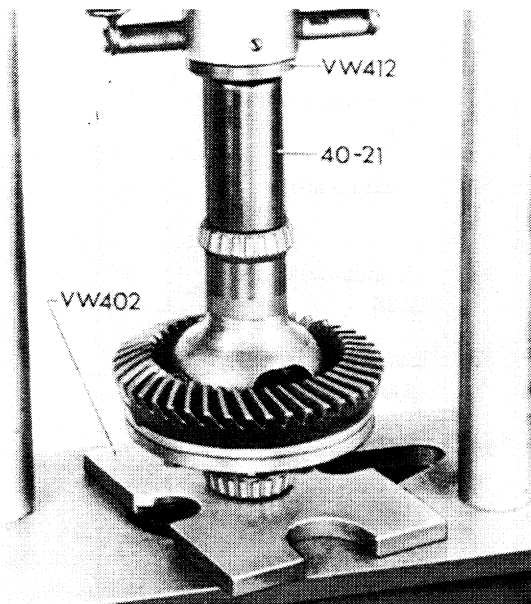

. Tools

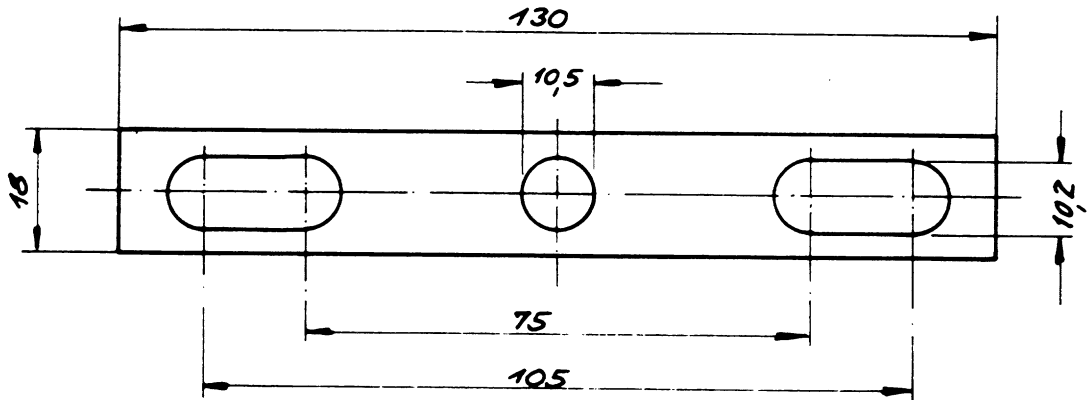

| No. | Description | Special Tool | Remarks   |
|-----|-------------|--------------|---|
|     | Connector   | ---          | Made locally. The joint flange connector may be made of 6 x 18 mm flat steel bar. |

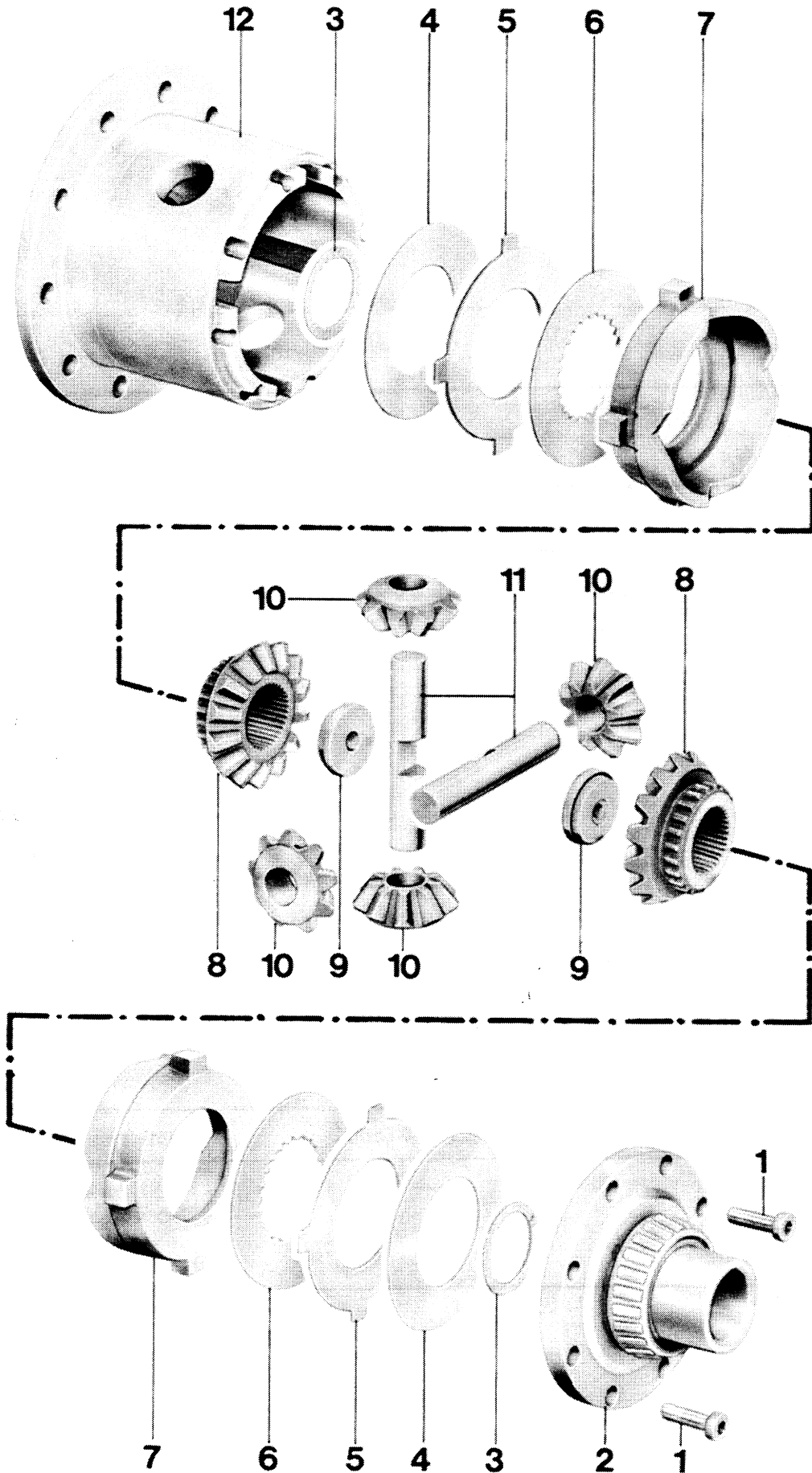

| No. | Description                        | Qty. | Note When:                      |   | Special Instructions |
|-----|------------------------------------|------|---------------------------------|---|----------------------|
|     |                                    |      | Removing                        | Installing                                |                      |
| 1   | Bolt                               | 8    |                                 | Coat with Loctite 262 and torque to 38 Nm |                      |
| 2   | Case cover                         | 1    |                                 |   |                      |
| 3   | Thrust washer                      | 2    |                                 | Position correctly                        |                      |
| 4   | Diaphragm spring                   | 2    |                                 | Position correctly                        |                      |
| 5   | Outer plate                        | 2    |                                 |   |                      |
| 6   | Inner plate<br>(molybdenum coated) | 2    |                                 |   |                      |
| 7   | Pressure ring                      | 2    |                                 |   |                      |
| 8   | Differential gear                  | 2    |                                 |   |                      |
| 9   | Threaded ring                      | 2    | Press out of differential gear. | Press in to correct position.             |                      |
| 10  | Differential pinion                | 4    |                                 |   |                      |
| 11  | Differential shaft                 | 2    |                                 |   |                      |
| 12  | Differential case                  | 1    |                                 |   |                      |



## DISASSEMBLING AND ASSEMBLING LIMITED SLIP DIFFERENTIAL (40 % LOCK)

## Disassembling

1. Unscrew socket head bolts on case cover and take off cover.

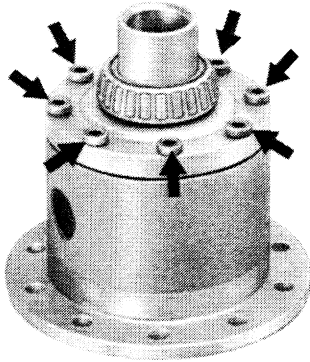

2. Take out all parts inside of case.

## Assembling

1. Inspect all parts for wear or damage, replacing if necessary.
- a) Differential Case:  
Check guide grooves for outer plates and pressure rings for wear.

- b) Pressure Rings:  
Guide tabs and bearing surfaces must not be worn or scored excessively. They must also slide easily in the differential case.
  - c) Differential Gears:  
Bearing surfaces for thrust washers must not be worn and inner plates must slide easily on splines of gears.
  - d) Plates:  
Check inner and outer plates for wear. Guide tabs of outer plates and teeth of inner plates must not be worn.
2. Lubricate all sliding surfaces on plates, pressure rings and differential shafts with SAE 80 hypoid gear lube prior to installation.
  3. Install thrust washers that retainers engage in bores of case or cover. It is recommended to hold washers in position with grease to make assembly work easier.

4. Install remaining parts as shown in the assembly drawing.

1. Measure case depth "a" with a depth gage.  
Example:  $a = 77.50$  mm.

#### Note

Diaphragm springs must be installed that curved surfaces face out toward the joint flange.

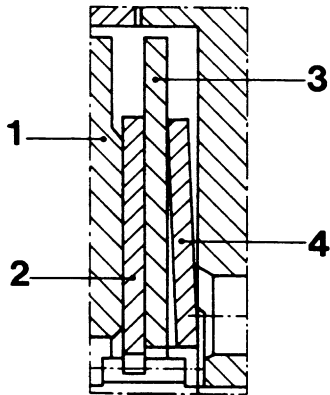

- 1 - Pressure ring  
2 - Inner plate  
3 - Outer plate  
4 - Diaphragm spring

**Determining Thickness of Plate Assembly:**  
If new parts are used, the thickness of the plate assembly has to be determined again.

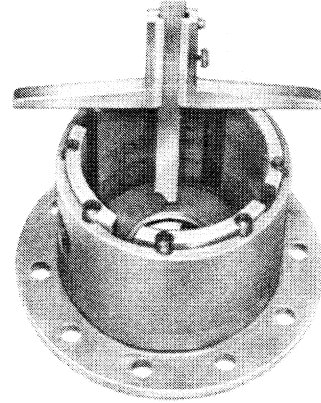

2. Determine thickness "b" of plate assembly (with 2.0 mm thick outer plates, but without diaphragm springs). Clamp plate assembly in a vise lightly and measure distance "b" with a sliding calipers.  
Example:  $b = 73.20$  mm.

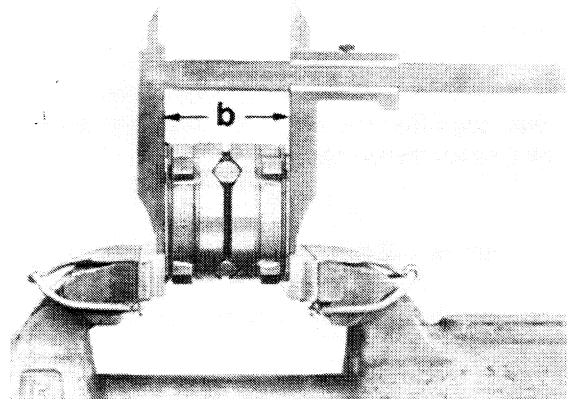

3. Figure out distance "e" (must be 4.2 mm).  
 $e = a - b$

Example:

$$a = 77.50 \text{ mm}$$

$$b = 73.30 \text{ mm}$$

$$c = \underline{\underline{4.20 \text{ mm}}}$$

4. After assembling, check slip torque with one differential gear held tight and one driven. This is done by clamping a flange with two bolts in a vise and placing the differential on it. Insert second flange with a locally made connector and turn differential with a torque wrench. A torque of 10 to 35 Nm must be reached.

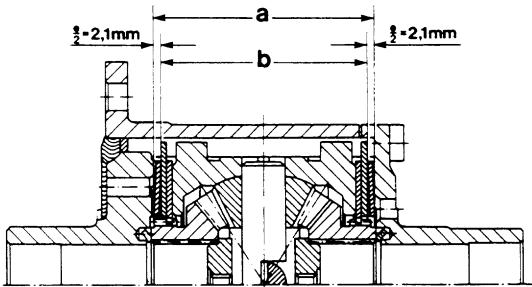

$$e_1 + e_2 = 4.2 \text{ mm}$$

**Note**

If determined distance is more or less than specified distance "e", install thicker or thinner outer plates.

"e" below 4.2 mm = use thinner plates.

"e" above 4.2 mm = use thicker plates.

Outer plates are available in thicknesses of 1.9 mm, 2.0 mm and 2.1 mm.

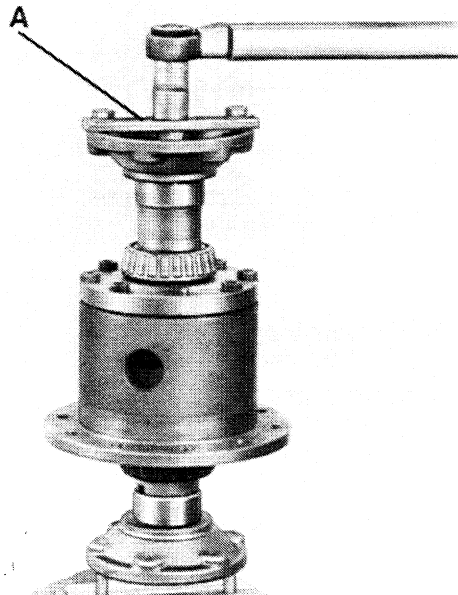

A = Connector (made locally)

**Note**

Plates are worn and have to be replaced, if the specified torque is not reached with the thickest outer plates.

## TOOLS

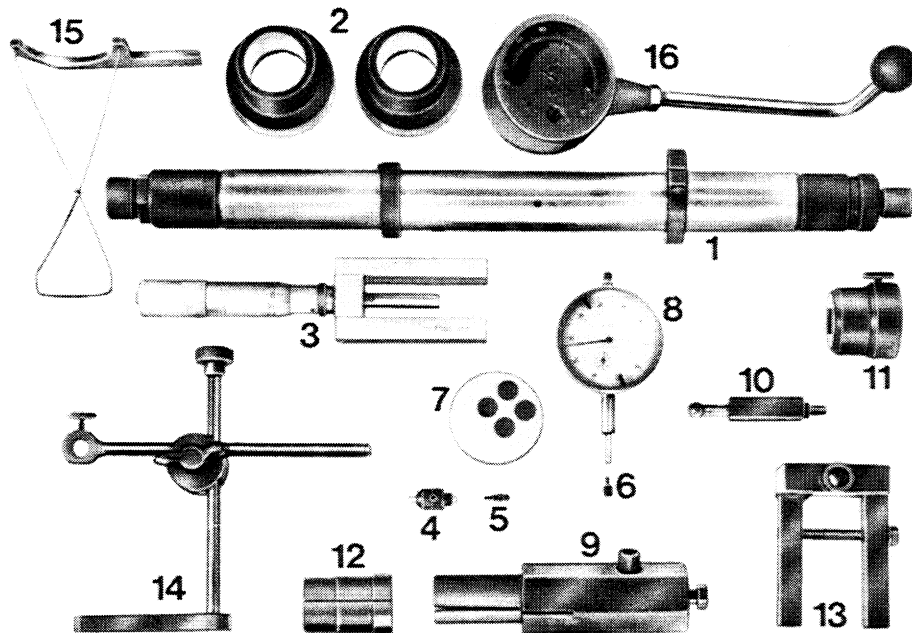

| No. | Description                           | Special Tool           | Remarks |
|-----|---------------------------------------|------------------------|---------|
| 1   | Universal gauge                       | VW 385                 |         |
| 2   | Centering disc                        | VW 385/2               |         |
| 3   | Master gauge                          | VW 385/26 or VW 385/30 |         |
| 4   | Gauge plunger                         | VW 385/13              |         |
| 5   | Dial gauge extension<br>(9.3 mm long) | VW 385/15              |         |
| 6   | Dial gauge extension                  | VW 382/10              |         |
| 7   | Master gauge plate                    | VW 385/17              |         |
| 8   | Dial gauge                            | US 1026 or US 1027     |         |
| 9   | Adjusting device                      | VW 521/4               |         |
| 10  | Measuring lever                       | VW 388                 |         |

| No. | Description       | Special Tool | Remarks                                   |
|-----|-------------------|--------------|---|
| 11  | Clamp             | 3022         | Open up mounting bore to 10.5 mm diameter |
| 12  | Sleeve            | VW 521/8     |   |
| 13  | Clamp             | VW 386 a     |   |
| 14  | Dial gauge holder | VW 387       |   |
| 15  | End gauge         | VW 385/28    |   |
| 16  | Torque gauge      | US 1064      |   |

### Adjusting Pinion/Ring Gear – General Information

Accurate adjustments of the pinion and ring gear are immensely important for the service life and smooth running of the final drive. This is why pinions and ring gears are paired during manufacture and checked in special machines for tooth pattern and quietness in both directions of rotation. The position of smoothest running is determined by moving the pinion in an axial direction, whereby the ring gear is lifted out of the no-play meshing position far enough so that the backlash will be kept within specified tolerances.

Deviation "r", in reference to master gage "R<sub>0</sub>", of the special testing machine used in manufacturing is measured and recorded on the outer periphery of the ring gear. Pinion and ring gear must always be replaced together.

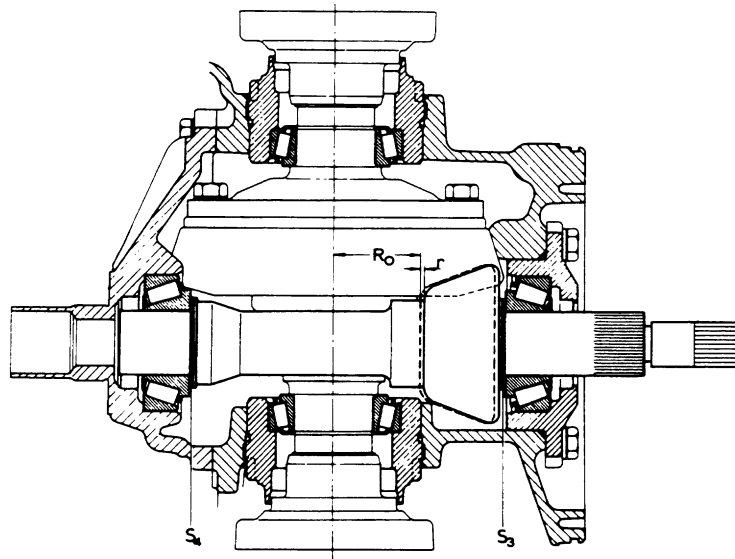

#### Location of Shims

R<sub>0</sub> – Length of master gage used in special testing machine  
"R<sub>0</sub>" = 46.60 mm.

r – Deviation from master gage used in special testing machine in manufacturing. "r" is always given in 1/100 mm.  
Example: "32" means r = 0.32 mm.

S<sub>3</sub> – Shim behind head of pinion.

S<sub>4</sub> – Shim opposite head of pinion.

Objective of adjustments must be to regain the maximum degree of quiet running, as had been determined by the special testing machine in manufacturing.

1 – Mark "G 1237" means Gleason pinion/ring gear, ratio 12 : 37.

2 – Matching pair number of pinion/ring gear set.

3 – Deviation "r".

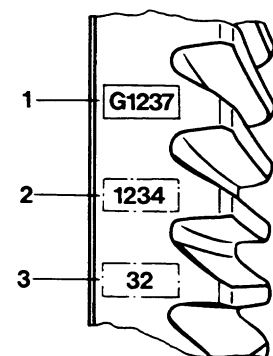

Adjusting Pinion

1. Heat pinion bearing inner race (large bearing) to about 100 °C/212 °F, install on pinion without shim and press on with a force of about 3 tons.
2. Heat pinion bearing inner race (small bearing) to about 100 °C/212 °F, install on pinion with 1.1 mm thick shim (arrow) and press on with force of about 3 tons.

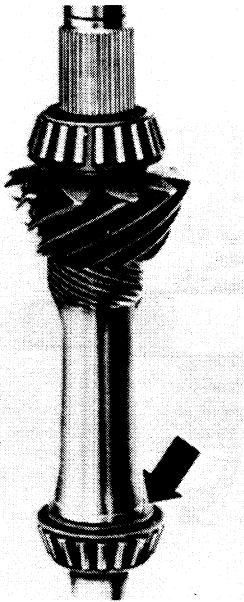

Note :

Pinion would hit housing while measuring and cause incorrect readings, if shim is omitted.

3. Install final drive housing cover without seals. Tighten all bolts to specified torque.

4. Install pinion and pinion cover. Tighten all bolts to specified torque.
5. Place VW 387 on housing and VW 385/17 on pinion. Install dial gage and adjust to zero.

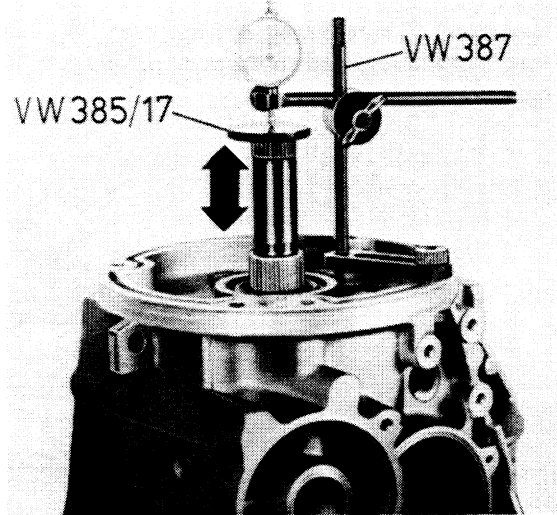

6. Move pinion up and down without turning it several times and note dial gage reading.

Note :

Readings would be wrong if pinion is turned.

7. Add 1.1 mm for installed shims, 0.15 mm for bearing preload and 0.10 mm for bearing settling to dial gage reading. This results in  $S_{tot}$ .

Example:

|                      |           |
|----------------------|-----------|
| Dial gage reading    | 1.81 mm   |
| Installed shim       | + 1.10 mm |
| Bearing preload      | + 0.15 mm |
| Bearing settling     | + 0.10 mm |
| Total shim thickness | = 3.16 mm |

8. Remove pinion. Take out installed shim (1.1 mm) and install shims of total thickness (3.16 mm in example) at small bearing.

9. Install pinion again and check deviation "e". Deviation "e" is the difference between the actual measurement R and the design measurement  $R_0$ .

10. Turn pinion in both directions several times.

11. Place VW 385/28 on pinion.

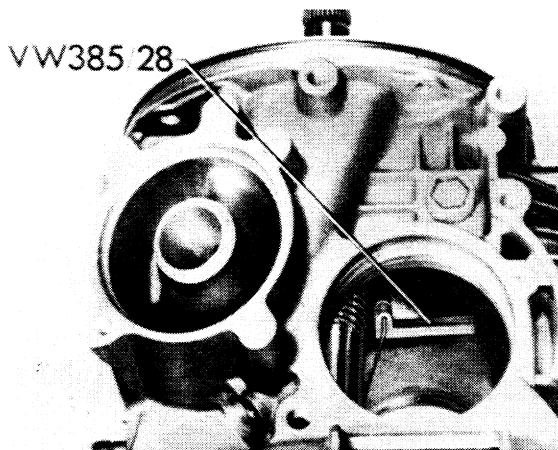

12. Set adjusting ring of VW 385/1 at distance a.  
a = approx. 82 mm.



13. Assemble VW 385/1 according to figure (dial gage extension VW 385/15 = 9.3 mm). Install VW 385/30 and set dial gauge at zero with 3 mm preload.

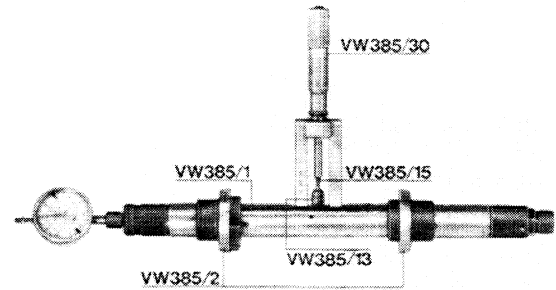

14. Screw adjusting ring (opposite ring gear) into case far enough so that it is flush with housing.

15. Insert universal gage in housing and screw in adjusting ring (behind ring gear). Do not place dial gage pin on end gage.

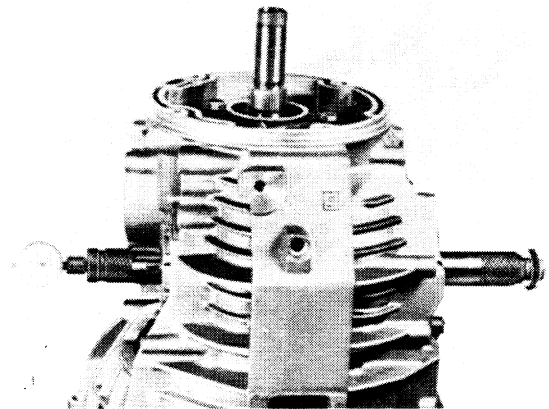

16. Pull 2nd centering disc outward with movable adjusting ring until universal gage can just barely be turned by hand.

17. Turn universal gage until dial gage pin touches end gage and shows maximum deflection (return point). Take dial gage reading.

18. Note measured distance "e" (example: 1.88 mm) and determine thickness of shims  $S_3$  and  $S_4$ .



Arrangement of Gages to Determine Deviation e

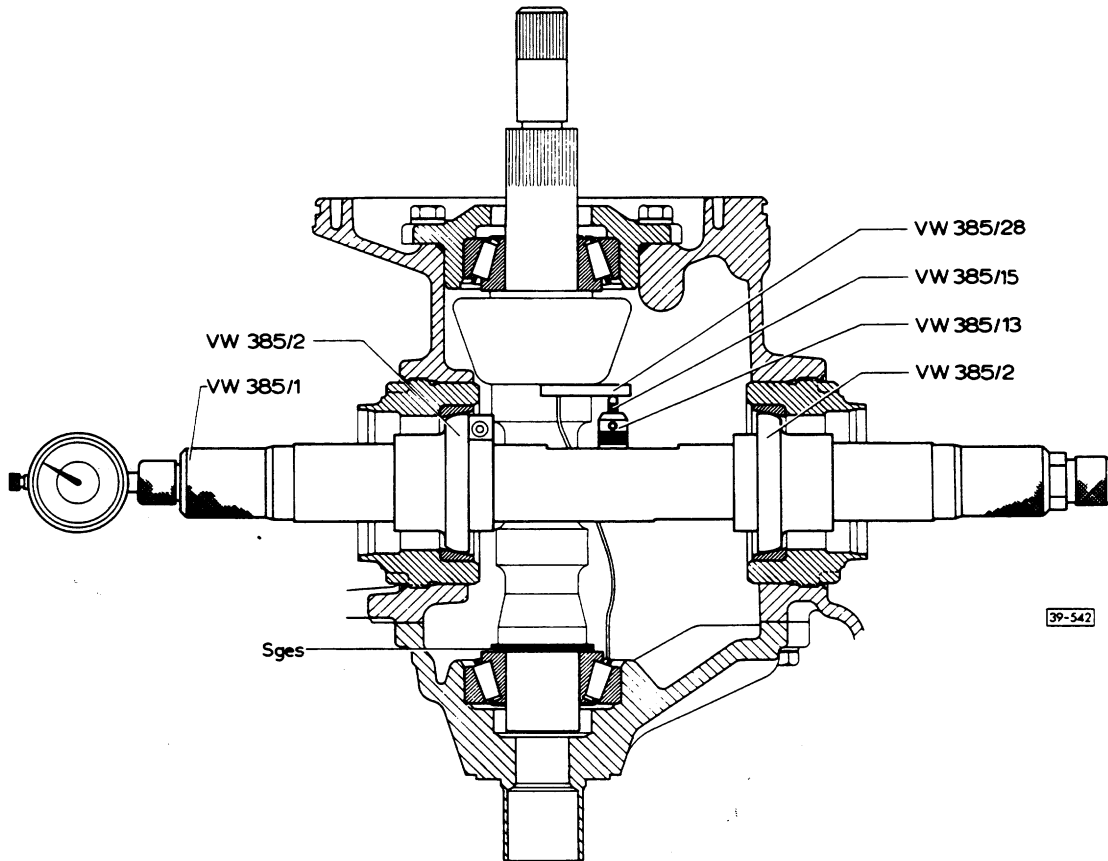

19. Determine thickness of shim "S<sub>3</sub>".

$$"S_3" = e - r$$

Example:

|                                     |                |
|-------------------------------------|----------------|
| Dial gage reading "e"               | 1.88 mm        |
| Ring gear value "r"                 | - 0.32 mm      |
| Thickness of shim "S <sub>3</sub> " | <u>1.56 mm</u> |

21. Determine thickness of shim "S<sub>4</sub>".

$$"S_4" = "S_{tot.}" - "S_3"$$

Example:

|                                  |                |
|----------------------------------|----------------|
| Total shim thickness             | 3.16 mm        |
| Shim thickness "S <sub>3</sub> " | - 1.56 mm      |
| Shim thickness "S <sub>4</sub> " | <u>1.60 mm</u> |

20. Select shims from table.

| Shim Range    | Shim to be installed | Part Number    |
|---------------|----------------------|----------------|
| 1.05 – 1.100  | 1.100                | 087 409 641 D  |
| 1.105 – 1.125 | 1.125                | 087 409 641 E  |
| 1.130 – 1.150 | 1.150                | 087 409 641 F  |
| 1.155 – 1.175 | 1.175                | 087 409 641 G  |
| 1.180 – 1.200 | 1.200                | 087 409 641 H  |
| 1.205 – 1.225 | 1.225                | 087 409 641 J  |
| 1.230 – 1.250 | 1.250                | 087 409 641 K  |
| 1.255 – 1.275 | 1.275                | 087 409 641 L  |
| 1.280 – 1.300 | 1.300                | 087 409 641 M  |
| 1.305 – 1.325 | 1.325                | 087 409 641 N  |
| 1.330 – 1.350 | 1.350                | 087 409 641 P  |
| 1.355 – 1.375 | 1.375                | 087 409 641 Q  |
| 1.380 – 1.400 | 1.400                | 087 409 641 R  |
| 1.405 – 1.425 | 1.425                | 087 409 641 S  |
| 1.430 – 1.450 | 1.450                | 087 409 641 T  |
| 1.455 – 1.475 | 1.475                | 087 409 641 AA |
| 1.480 – 1.500 | 1.500                | 087 409 641 AB |
| 1.505 – 1.525 | 1.525                | 087 409 641 AC |
| 1.530 – 1.550 | 1.550                | 087 409 641 AD |
| 1.555 – 1.575 | 1.575                | 087 409 641 AE |
| 1.580 – 1.600 | 1.600                | 087 409 641 AF |
| 1.605 – 1.625 | 1.625                | 087 409 641 AG |
| 1.630 – 1.650 | 1.650                | 087 409 641 AH |
| 1.655 – 1.675 | 1.675                | 087 409 641 AJ |
| 1.680 – 1.700 | 1.700                | 087 409 641 AK |
| 1.705 – 1.725 | 1.725                | 087 409 641 AL |
| 1.730 – 1.750 | 1.750                | 087 409 641 AM |
| 1.755 – 1.775 | 1.775                | 087 409 641 AN |
| 1.780 – 1.800 | 1.800                | 087 409 641 AP |
| 1.805 – 1.825 | 1.825                | 087 409 641 AQ |
| 1.830 – 1.850 | 1.850                | 087 409 641 AR |
| 1.855 – 1.875 | 1.875                | 087 409 641 AS |
| 1.880 – 1.900 | 1.900                | 087 409 641 AT |

22. Select shims from table.

| Shim Range    | Shim to be installed | Part Number    |
|---------------|----------------------|----------------|
| 1.05 – 1.100  | 1.100                | 082 519 141 AE |
| 1.105 – 1.125 | 1.125                | 082 519 141 AF |
| 1.130 – 1.150 | 1.150                | 082 519 141 AG |
| 1.155 – 1.175 | 1.175                | 082 519 141 AH |
| 1.180 – 1.200 | 1.200                | 082 519 141 AJ |
| 1.205 – 1.225 | 1.225                | 082 519 141 AK |
| 1.230 – 1.250 | 1.250                | 082 519 141 AL |
| 1.255 – 1.275 | 1.275                | 082 519 141 AM |
| 1.280 – 1.300 | 1.300                | 082 519 141 AN |
| 1.305 – 1.325 | 1.325                | 082 519 141 AP |
| 1.330 – 1.350 | 1.350                | 082 519 141 AQ |
| 1.355 – 1.375 | 1.375                | 082 519 141 AR |
| 1.380 – 1.400 | 1.400                | 082 519 141 AS |
| 1.405 – 1.425 | 1.425                | 082 519 141 AT |
| 1.430 – 1.450 | 1.450                | 082 519 141 BA |
| 1.455 – 1.475 | 1.475                | 082 519 141 BB |
| 1.480 – 1.500 | 1.500                | 082 519 141 BC |
| 1.505 – 1.525 | 1.525                | 082 519 141 BD |
| 1.530 – 1.550 | 1.550                | 082 519 141 BE |
| 1.555 – 1.575 | 1.575                | 082 519 141 BF |
| 1.580 – 1.600 | 1.600                | 082 519 141 BG |
| 1.605 – 1.625 | 1.625                | 082 519 141 BH |
| 1.630 – 1.650 | 1.650                | 082 519 141 BJ |
| 1.655 – 1.675 | 1.675                | 082 519 141 BK |
| 1.680 – 1.700 | 1.700                | 082 519 141 BL |
| 1.705 – 1.725 | 1.725                | 082 519 141 BM |
| 1.730 – 1.750 | 1.750                | 082 519 141 BN |
| 1.755 – 1.775 | 1.775                | 082 519 141 BP |
| 1.780 – 1.800 | 1.800                | 082 519 141 BQ |
| 1.805 – 1.825 | 1.825                | 082 519 141 BR |
| 1.830 – 1.850 | 1.850                | 082 519 141 BS |
| 1.855 – 1.875 | 1.875                | 082 519 141 BT |
| 1.880 – 1.900 | 1.900                | 082 519 141 CA |

23. Check shim thickness at several positions with a micrometer. Check shims for burrs and damage. Only install perfect shims.
24. Install selected shims.  
"S<sub>3</sub>" behind pinion.  
"S<sub>4</sub>" opposite pinion.
25. Install pinion and lubricate bearings with hypoid gear oil.
26. Check measurements.  
Install universal gage. Set dial gage at 0 with 3 mm preload. If proper shims have been installed, dial gage reading must be specified deviation "r" within a tolerance of  $\pm 0.04$  mm (red gage range).
27. After installation of pinion with the selected shims the turning torque must also be measured. It must be 250 to 550 Ncm (22 – 48 in. lb).  
This value applies to new bearings. Measure actual turning torque before disassembly if used bearings are to be installed again.

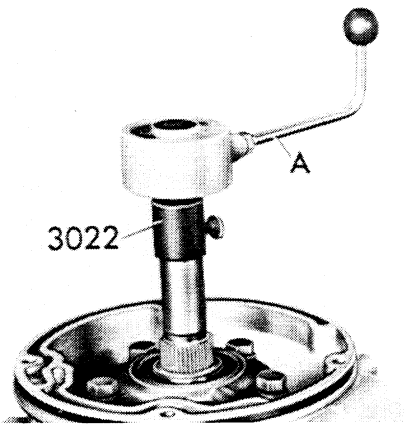

A – US 1064 torque gage  
0 – 600 Ncm (0 – 500 in. lb)

### Adjusting Ring Gear

After adjustment of pinion, remove cover for final drive housing and cover for pinion.

1. Install differential and pinion. Insert seals in both covers and install cover for final drive housing. Coat sealing surface with D 3 sealer. Mount cover for pinion and tighten all bolts of both covers to specified torque.
2. Apply a light coat of multi-purpose grease to O-rings and threads of adjusting rings. Lubricate bearings with hypoid gear oil and tighten both adjusting rings until the surfaces between teeth are at same height as housing surface.
3. Continue adjusting the adjusting ring behind ring gear carefully, until teeth of ring gear mesh with pinion without play.
4. Tighten adjusting ring opposite ring gear as far as possible and preload slightly so there is no play in bearings.

5. Turn adjusting ring behind ring gear back by 1/2 tooth (direction of arrow).

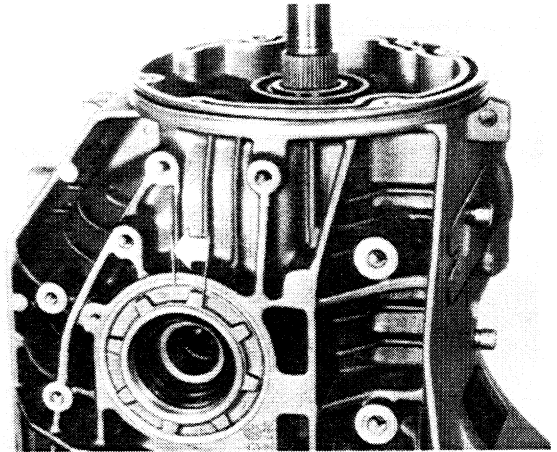

6. Turn adjusting ring opposite ring gear by 2 teeth (direction of arrow). This completes adjustment of the necessary bearing preload and specified backlash.

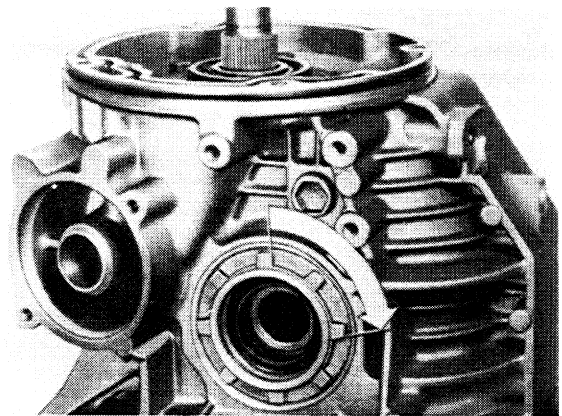

## Checking Backlash

1. Turn pinion in both directions several times.
2. Mount VW 386 a on pinion cover and hold pinion tight with clamping bolt.

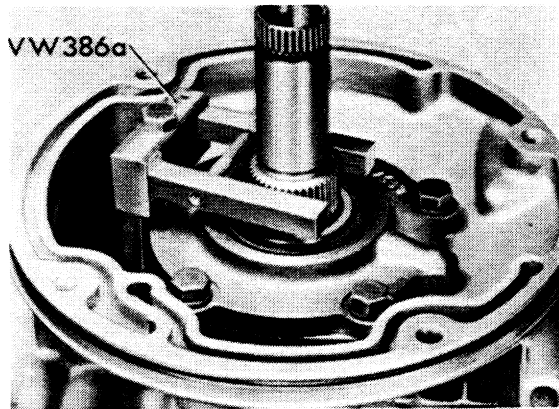

3. Adjust VW 388 to distance  $a = 68$  mm and install VW 521/4.

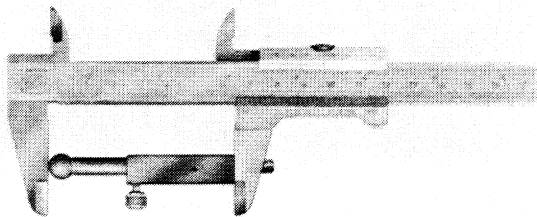

4. Install dial gage with square-ended extension in VW 387.

5. Insert VW 521/4 with VW 521/8 and mount VW 387.

6. Check backlash on circumference at four places. Specifications = 0.15 – 0.25 mm.

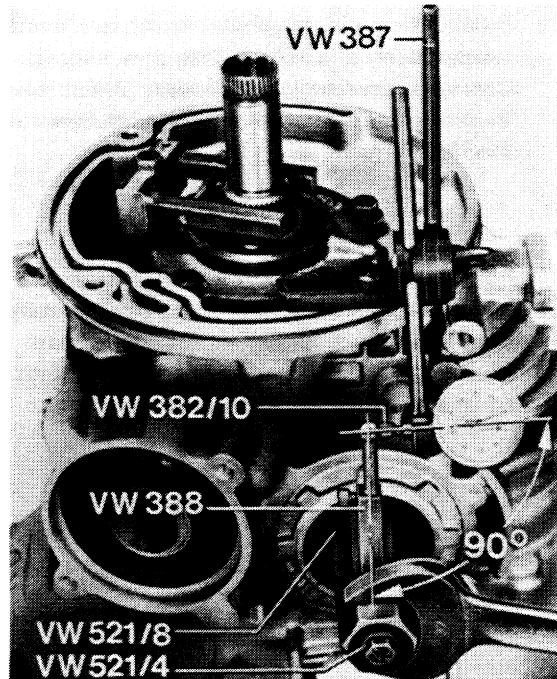

## Note :

Separate measurements must not differ from each other by more than 0.05 mm.  
The above specification applies only to new pinion/ring gear sets; for old sets adjust backlash to previous value as accurately as possible.

7. If backlash of a new pinion/ring gear set is outside specifications, it must be corrected by turning both adjusting rings evenly. Do not change bearing preload.

8. Finally measure total turning torque on pinion for all 4 tapered roller bearings.

Total turning torque must exceed turning torque of pinion by at least 40 Ncm (3,5 in. lb); if necessary increase torque by tightening both adjusting rings accordingly.

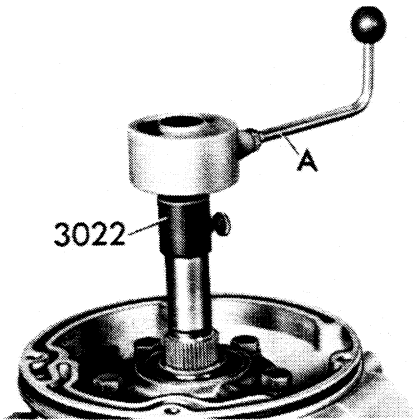

A – US 1064 torque gage  
0 – 600 Ncm (0 – 500 in. lb)

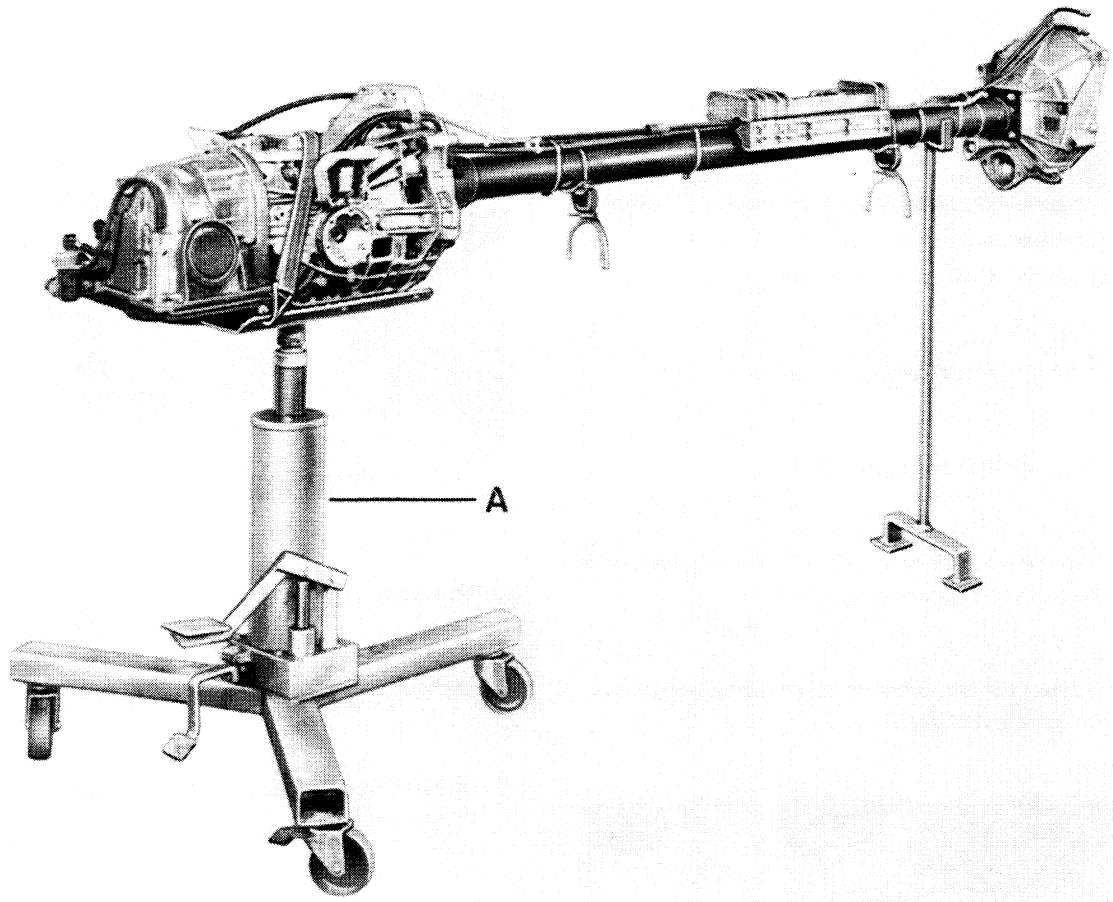

A = Universal transmission jack

## REMOVING AND INSTALLING CENTRAL TUBE

## Removing

**Note**

When performing operations on the transaxle system that involve rotating or shifting the transaxle tube, always wear leather gloves to avoid injuries

1. Take off rear wheels.
2. Disconnect battery ground lead.
3. Disconnect parking brake cable on parking brake lever and pull back out of guide.
4. Loosen control cable on bracket and disconnect on accelerator pedal.

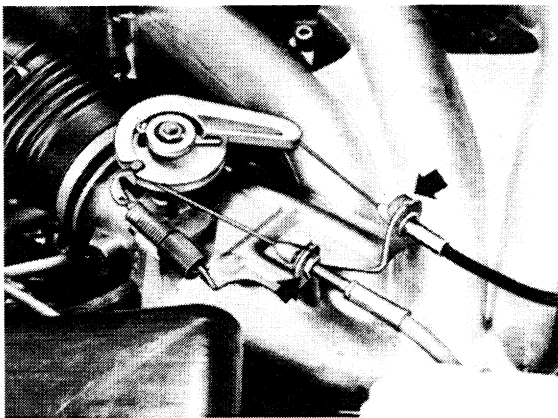

5. Press control cable out of rubber guide in firewall and pull out cable forward.  
Disconnect suspension clamps on engine and front bell housing.

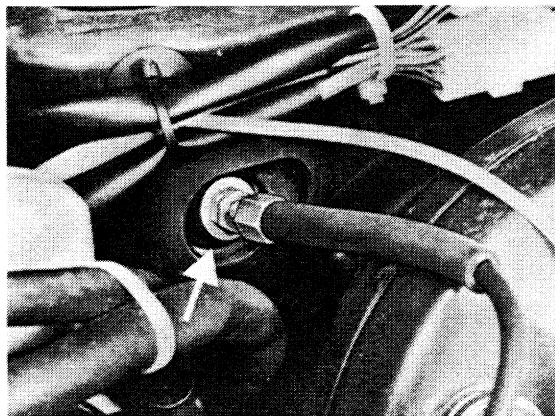

6. Remove splash shield.
7. Remove entire exhaust assembly.
8. Disconnect axle shafts on transmission end and remove rear axle.
9. Disconnect selector lever cable on transmission after removing lockpin for ball socket.

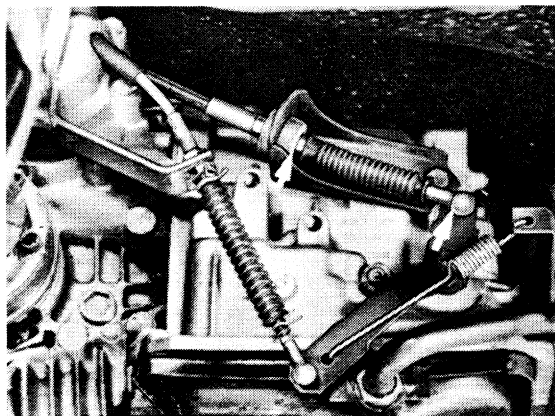

10. Loosen mounting clamps for starter wires on front bell housing and remove starter.



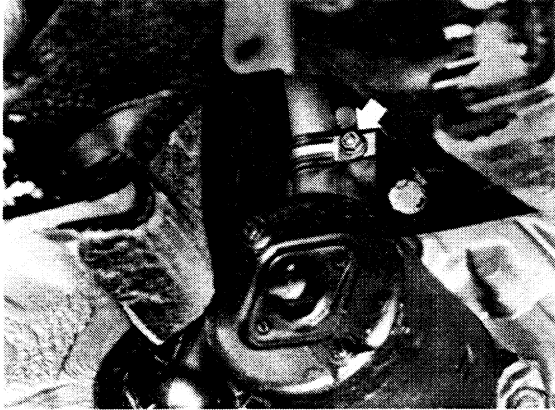

**Note :**

Suspend starter from suitable point on car so that the wire harness is not stretched.

11. Disconnect holder for ATF lines on camshaft housing.

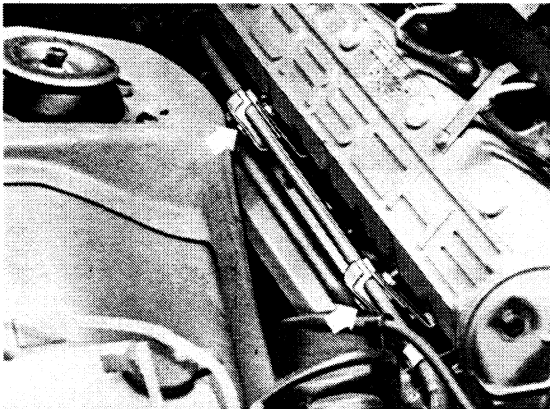
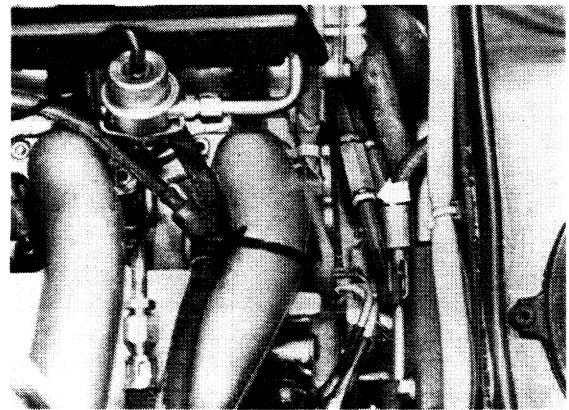

12. Disconnect ATF lines between firewall and engine.

13. Remove ground wire on clutch bell housing.

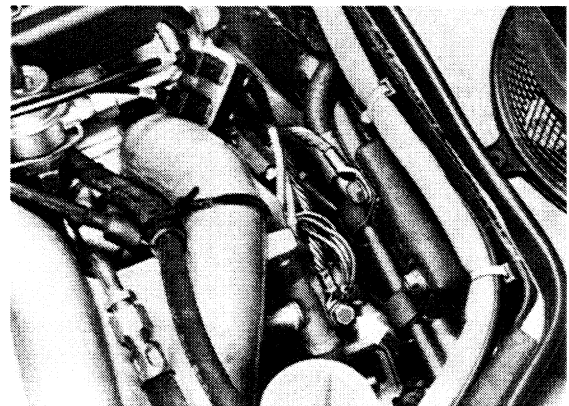

## Note:

Since the heater valve covers up the ground point, the coolant must be drained partially and the valve removed.

14. Unscrew screws for speed and reference mark transmitters. Pull out transmitters while turning back and forth at same time.

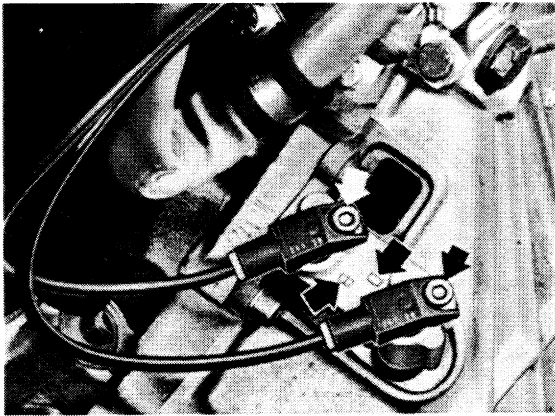

15. Unscrew clamp screw.

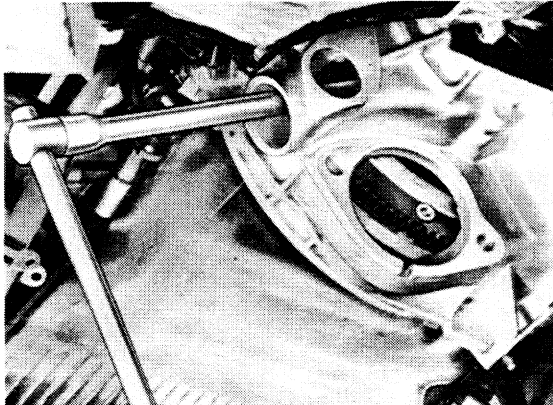

16. Mark position of flywheel/damper for reinstallation later or turn flywheel until marks in starter opening are visible.

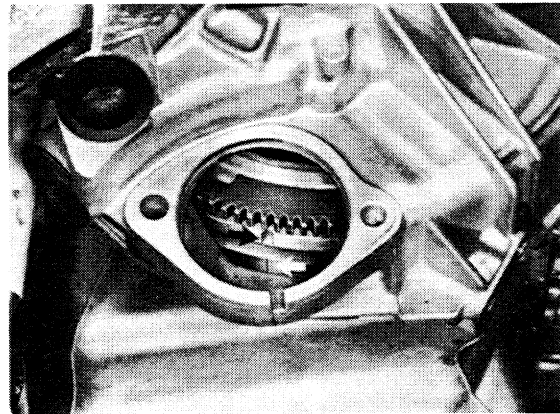

17. Unscrew damper mounting bolts (if necessary, hold tight on pulley bolt) and press damper off of flywheel.

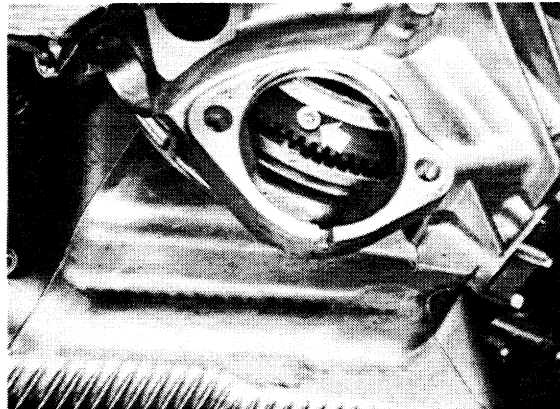

18. Position universal transmission jack underneath transmission and mount retaining strap.

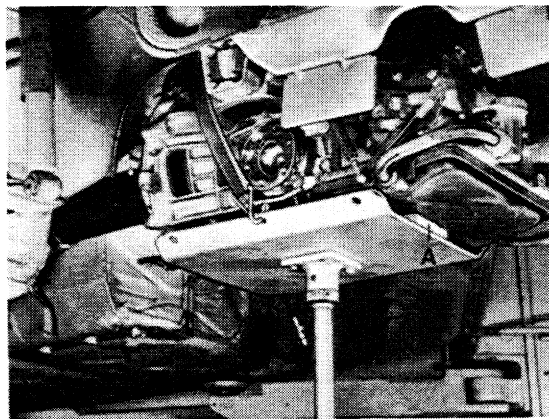

A – Wooden block

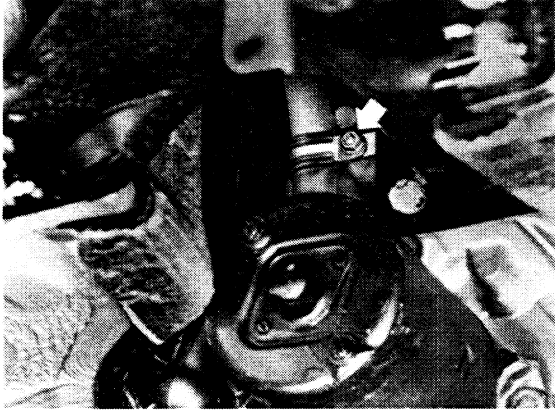

**Note :**

Suspend starter from suitable point on car so that the wire harness is not stretched.

11. Disconnect holder for ATF lines on camshaft housing.

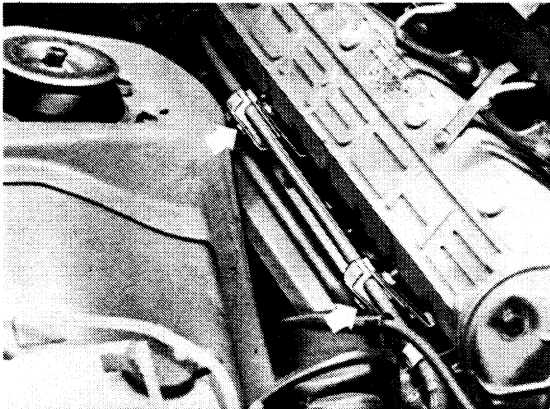
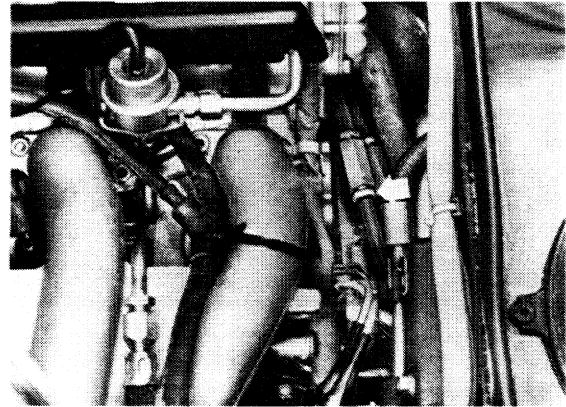

12. Disconnect ATF lines between firewall and engine.

13. Remove ground wire on clutch bell housing.

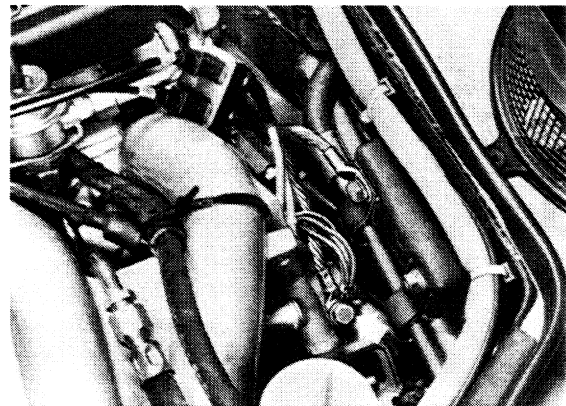

## Note:

Since the heater valve covers up the ground point, the coolant must be drained partially and the valve removed.

14. Unscrew screws for speed and reference mark transmitters. Pull out transmitters while turning back and forth at same time.

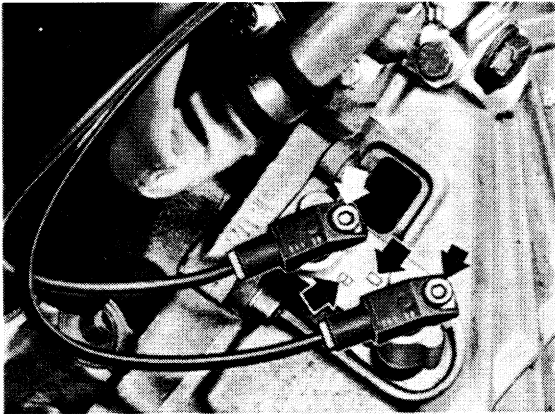

15. Unscrew clamp screw.

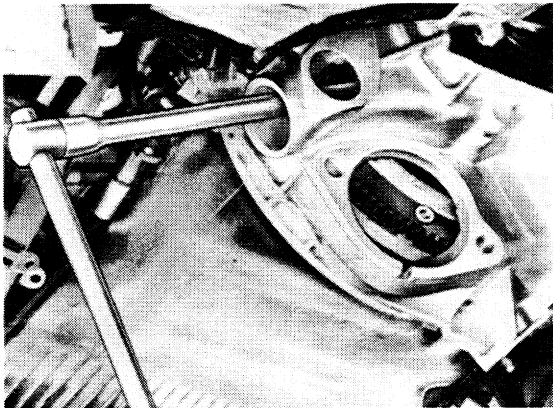

16. Mark position of flywheel/damper for reinstallation later or turn flywheel until marks in starter opening are visible.

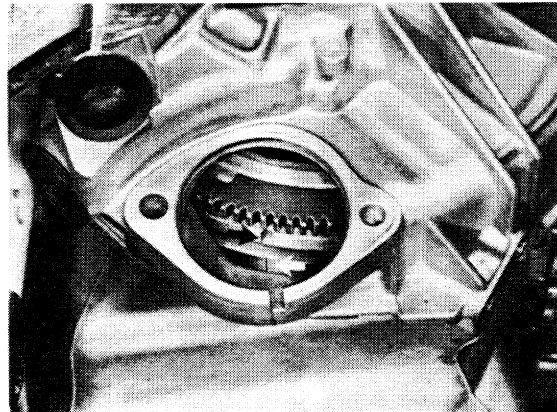

17. Unscrew damper mounting bolts (if necessary, hold tight on pulley bolt) and press damper off of flywheel.

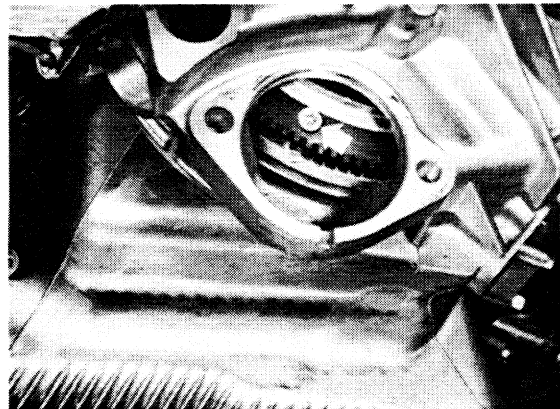

18. Position universal transmission jack underneath transmission and mount retaining strap.

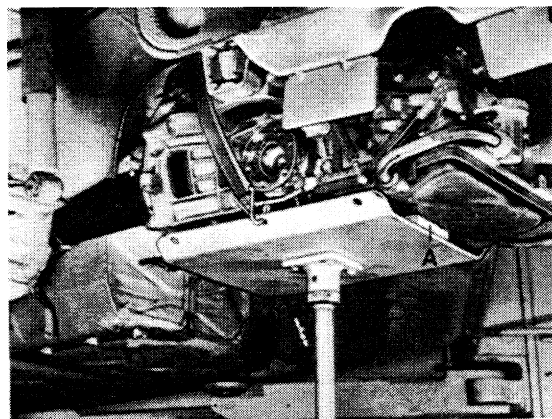

A – Wooden block

19. Unscrew mounting bolts for transmission suspension on transmission carrier.
20. Remove center and rear cross members. Hold engine in installed position with VW 10-222.
21. Unscrew bolts on engine block/front bell housing flange.
22. Pull back transmission with central tube.
23. Remove front cross member and lower central tube with transmission carefully without stretching or bending the control cable.

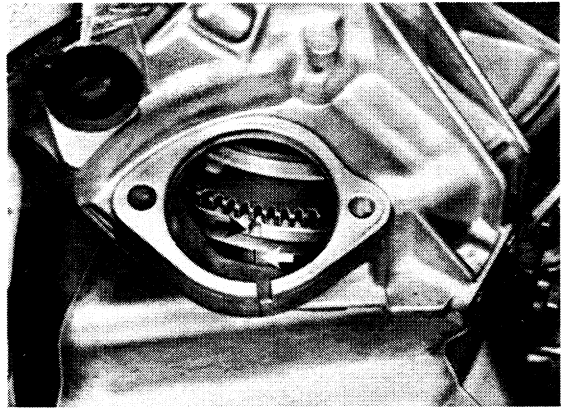

1. Wrap pieces of adhesive tape around insulation sheet and coat mating surfaces for body with an assembly paste (e. g. rubber lubricant) to facilitate installation.

**Note :**

This step requires an extra person on the front bell housing to balance the weight of the central tube for safety's sake.

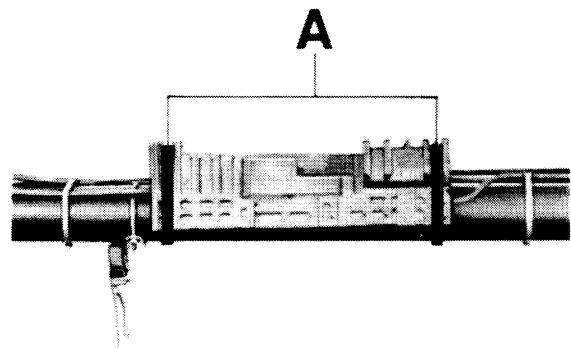

A – Adhesive tape

**Installing**

**Note :**

Installation marks (not TDC mark) on flywheel and damper must be aligned. Before installing the central tube, turn flywheel and damper until installation marks face down at an angle (toward starter opening).



2. Install speed and reference mark transmitters.

Note :

Transmitters have permanent magnets. Make sure metal particles are not stuck on the transmitters before installing.

Note marks of transmitters. Never use force to install them.

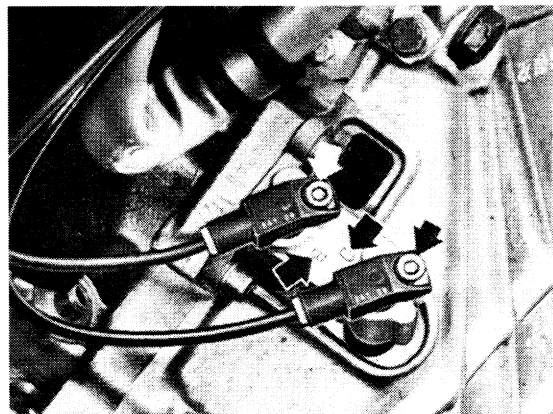
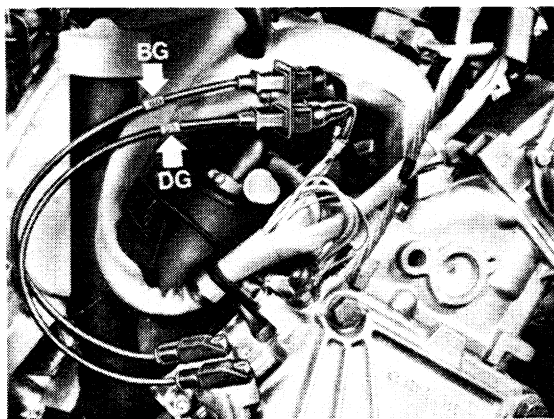

3. Install rubber grommet between selector lever cable and suspension console.

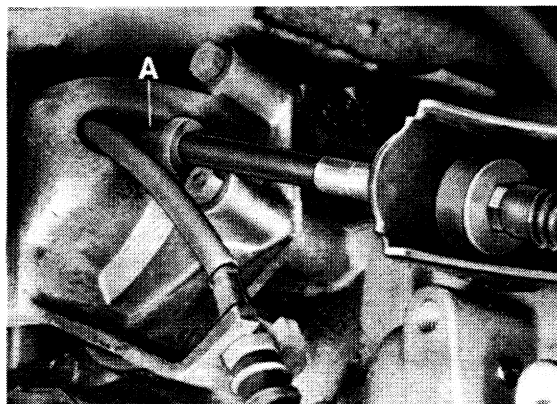

4. Adjust selector lever and control cables (see pages 37 - 7 and 37 - 11).

Tighten transmitters mounting screws to 8 Nm (6 ft lb) torque.

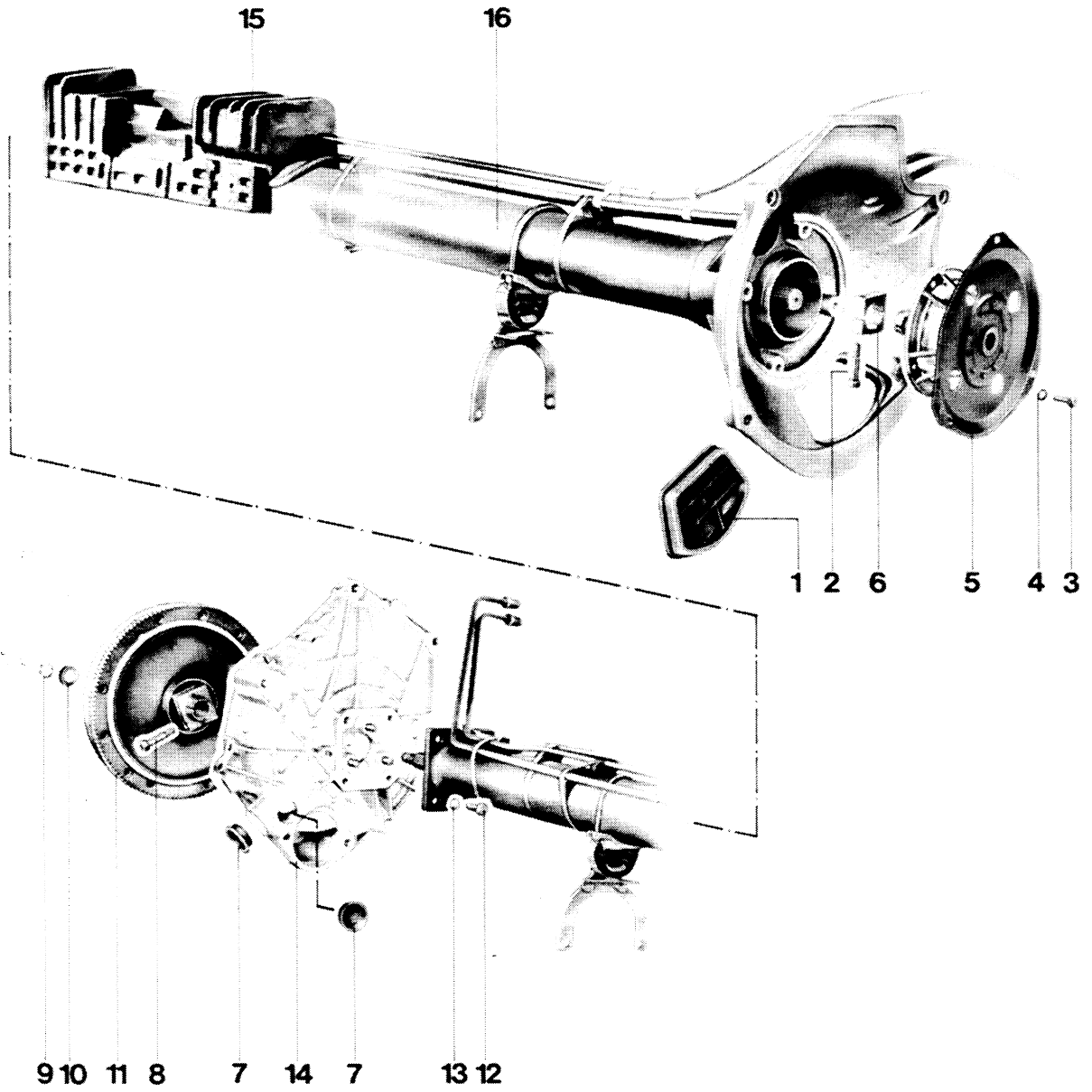

| No. | Description      | Qty. | Note When: |  | Special Instructions |
|-----|------------------|------|------------|--|----------------------|
|     |                  |      | Removing   | Installing   |                      |
| 1   | Cap              | 1    |            |  |                      |
| 2   | Bolt             | 1    |            | Torque:<br>80 Nm (58 ft lb)  |                      |
| 3   | Bolt             | 4    |            | Torque:<br>21 Nm (15 ft lb)  |                      |
| 4   | Washer           | 4    |            |  |                      |
| 5   | Bearing flange   | 1    |            |  |                      |
| 6   | Clamp            | 1    |            |  |                      |
| 7   | Cap              | 2    |            |  |                      |
| 8   | Bolt             | 1    |            | Torque:<br>80 Nm (58 ft lb)  |                      |
| 9   | Circlip          | 1    |            |  |                      |
| 10  | Spacer           | X    |            | Determine thickness if<br>necessary  |                      |
| 11  | Damper           | 1    |            | Check installed distance   |                      |
| 12  | Bolt             | 4    |            | Torque:<br>42 Nm (30 ft lb)  |                      |
| 13  | Washer           | 4    |            |  |                      |
| 14  | Housing          | 1    |            |  |                      |
| 15  | Insulation sheet | 1    |            | Position correctly.<br>Coat mating surfaces<br>for body with assembly<br>paste (e. g. rubber<br>lubricant) |                      |
| 16  | Central tube     | 1    |            | Check, replacing<br>complete if necessary  |                      |

### Note

When performing operations on the transaxle system that involve rotating or shifting the transaxle tube, always wear leather gloves to avoid injuries.



DISASSEMBLING AND ASSEMBLING CENTRAL TUBE

Disassembling

1. Detach transmission and prevent converter from falling out (see "Removing and Installing Transmission" on page 37 - 19).
2. Remove bearing flange.
3. Remove damper by sliding back damper with spacer against stop and taking out circlip.
4. Remove front bell housing.
5. Remove insulation sheet, ATF lines, control cable and suspension for exhaust assembly.

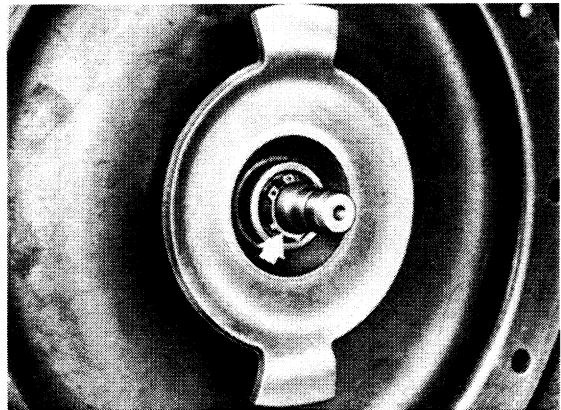

Assembling

1. Install ATF lines, control cable, suspension for exhaust assembly and insulation sheet.

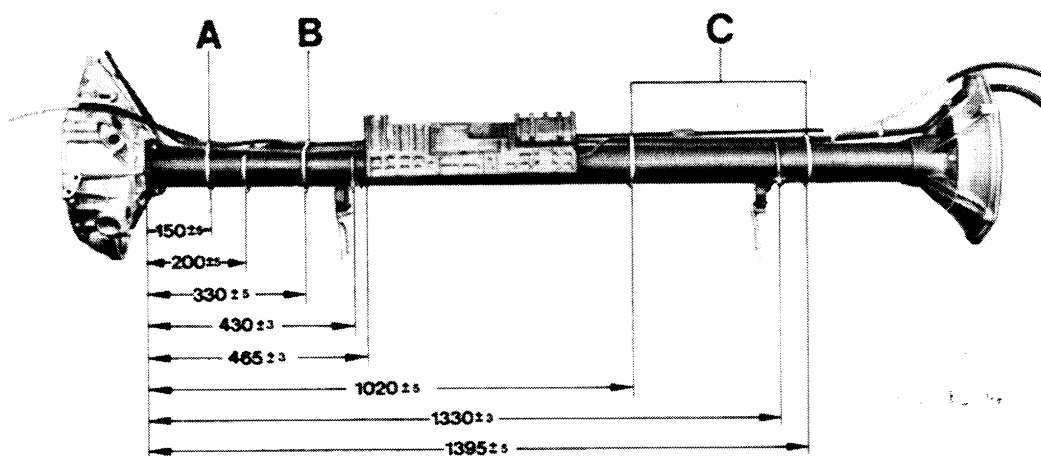
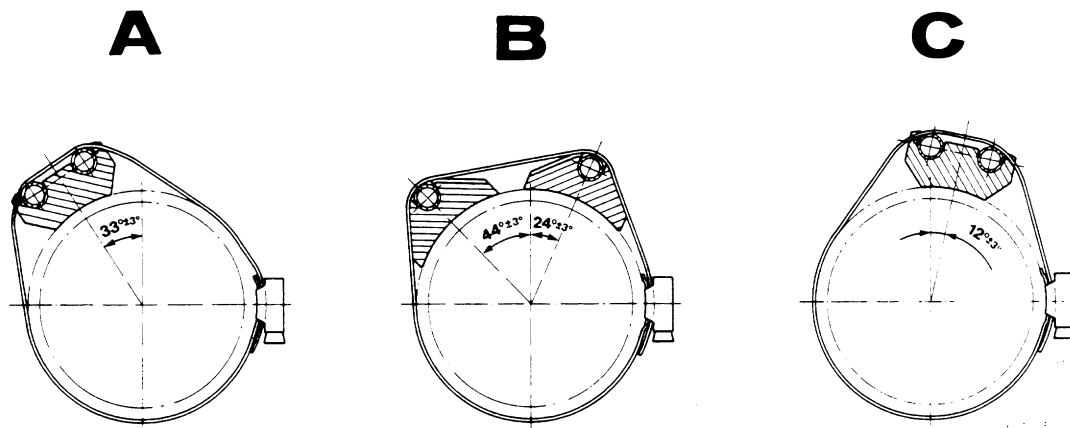

2. Apply a light coat of MoS<sub>2</sub> paste on splines of drive shaft with a brush.
  3. Adjust damper (see page 39 - 146).
-

## Checking Central Tube

### Note :

The complete central tube with shaft and bearings must be replaced, if the bearings or shaft are damaged. The replacement of separate parts is not possible.

1. Check easy movement of central tube bearings by turning the drive shaft by hand. The shaft must turn easily and without points of hesitation.
2. Check out-of-round deviation of drive shaft.  
Max. permissible deviation on engine end = 1.5 mm,  
on transmission end = 0.5 mm.
3. The position of the drive shaft to the rear flanged shaft is important for perfect function.  
Displacement of drive shaft to rear flange surface must be  $49 \pm 0.5$  mm.

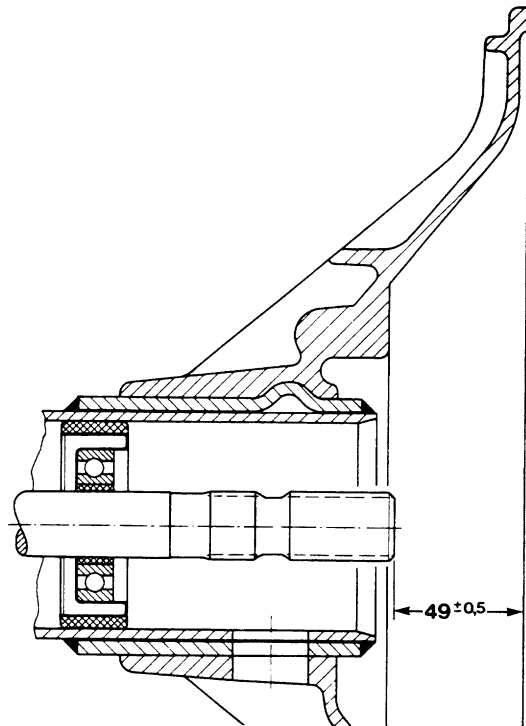

4. The displacement can be corrected slightly by tapping with a plastic hammer on face of drive shaft.

## Adjusting Damper

## Note:

The damper is adjusted to an installed distance of  $18 + 1.2$  mm by using spacers.  
Make measurement according to following procedures.

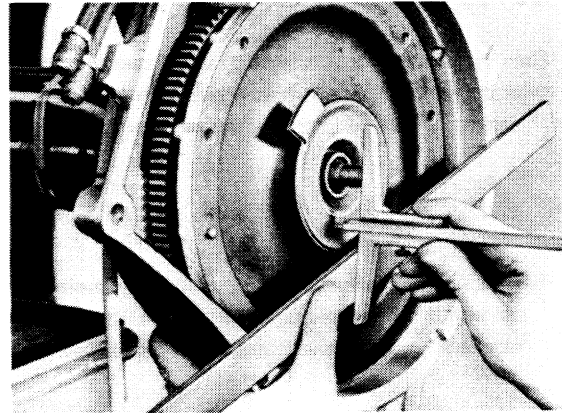
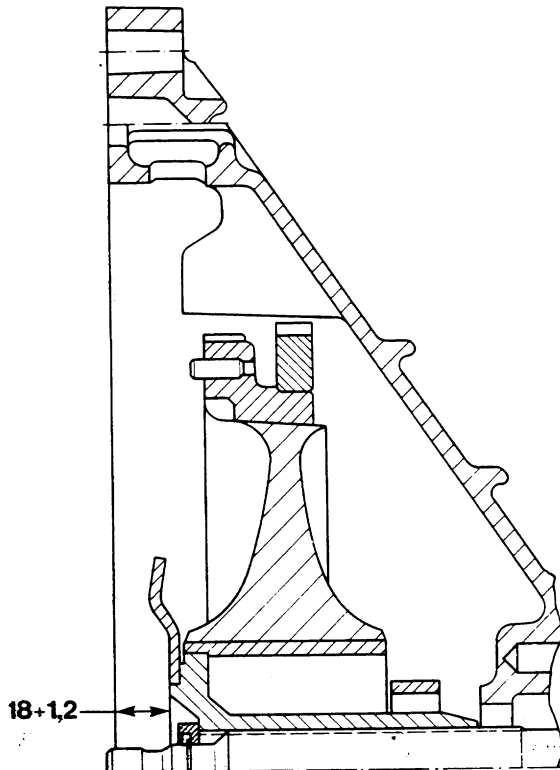

## Example:

|  |            |
|--|------------|
| Measured distance from bell housing edge to damper hub | 25.00 mm   |
| Thickness of straight-edge                             | – 5.00 mm  |
| Measured result  | 20.00 mm   |
| Specified value  | – 18.00 mm |
| Deviation from specified value                         | 2.00 mm    |

Remove 4 mm thick spacer and install a 6 mm thick spacer instead.  
Recheck.

## Note:

If measured result is less than specified value of 18 mm, a thinner spacer must be installed.

1. Install damper with a 4 mm thick spacer and insert circlip.
2. Push damper forward until it rests on circlip and tighten mounting bolt for clamping sleeve.
3. Place straight-edge on front bell housing and measure distance to drive dog.

Spacers are available as replacement parts in thicknesses from 1 mm to 8 mm.

4. Loosen clamping sleeve bolt and tighten again only after damper is mounted on flywheel.